

Adjustable Angle

BIMETAL THERMOMETERS



B85606 shown

- ▶ 3", 5" Dial Size
- ▶ ± 1.0% Full Scale Accuracy
- ▶ Stainless Steel Case & Stem
- ▶ External Reset

The Trerice **Adjustable Angle Bimetal Thermometer** can be configured to the most desirable viewing angle. This instrument has a hermetically sealed, stainless steel case designed to withstand the rigors of industrial environments, while producing an accurate, responsive measurement.

- Optional features available: Please consult the Options & Accessories Section for details.

Thermowell

- For corrosive or pressure applications, use of a thermowell is recommended to prevent damage to the thermometer and facilitate its removal from the process (refer to pages 155-161).

For correct use and application of all Bimetallic thermometers, please refer to the Bimetallic Actuated Thermometer Standard ASME B40.3.

Specifications

Models	Dial Sizes
B836	3"
B856	5"
Case	300 stainless steel, hermetically sealed
Stem	300 stainless steel 1/4" diameter
Coil	Bimetallic, silicone dampened on ranges to 300°F (148°C), above 300°F not dampened
Connection	Adjustable angle, 1/2 NPT
Window	Double strength glass
Pointer	Balanced, black finish
Dial Face	Aluminum, white background with black and blue graduations and markings
External Reset	Yes
Accuracy	±1.0 % Full Scale ASME B40.3 Grade A

Approximate Shipping Weight

B836: 1.1 lbs [0.5 kg]
B856: 1.5 lbs [0.68 kg]

HOW TO ORDER

Sample Order Number: **B856 06 05**

Model	Stem (Length)	Range Code
B836	02 2 1/2" Stem	See Standard Ranges
B856	04 4" Stem	
	06 6" Stem	
	09 9" Stem	
	12 12" Stem	
	15 15" Stem	
	18 18" Stem	
	24 24" Stem	

Other lengths available: Specify in inches (72" maximum)

Adjustable Angle

All dimensions are nominal. Dimensions in [] are in millimeters.

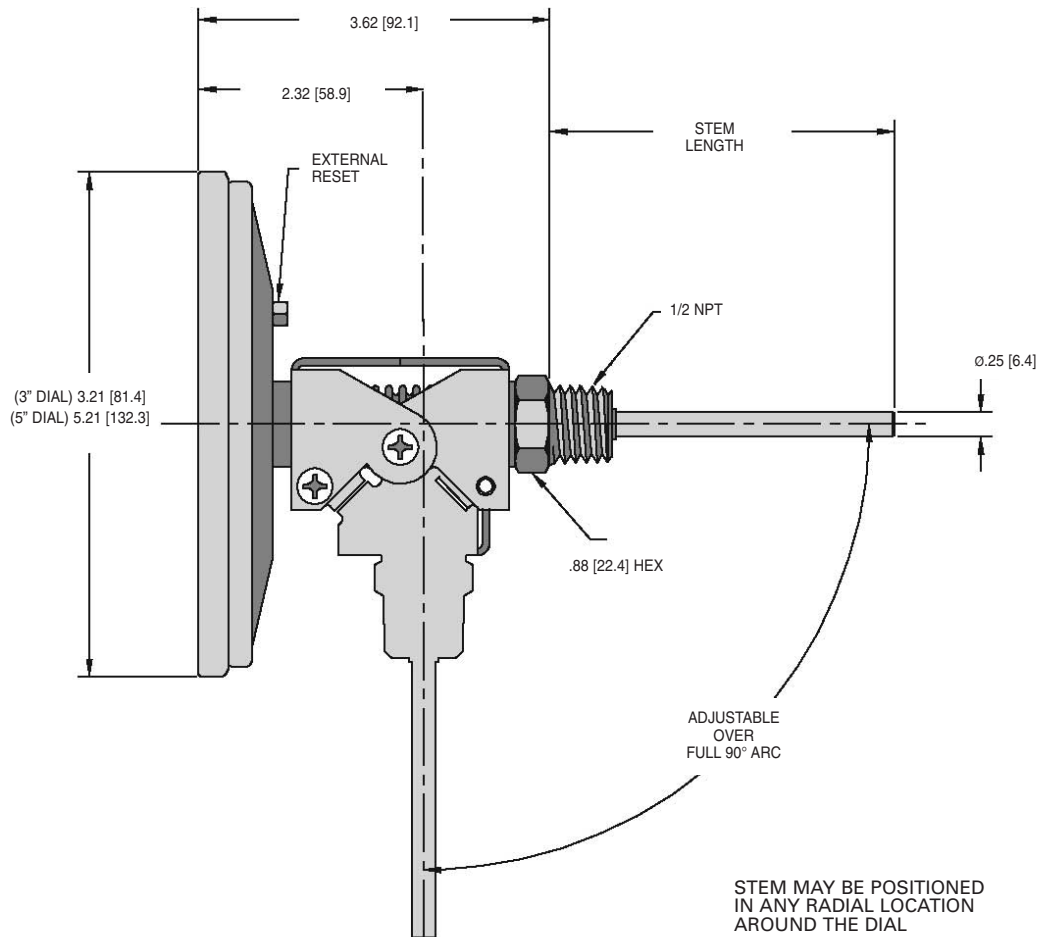

BIMETAL THERMOMETERS

Standard Ranges

Dual Scale (Fahrenheit & Celsius Range)		Fahrenheit only Range		Celsius only Range		Fahrenheit		Celsius	
Range Code	Range	Range Code	Range	Range Code	Range	Figure Intervals	Minor Divisions	Figure Intervals	Minor Divisions
01*†	-100° to 100°F & -75° to 40°C	01F*†	-100° to 100°F	01C*†	-75° to 40°C	20°	2°	10°	1°
02	-40° to 160°F & -40° to 70°C	02F	-40° to 160°F	02C	-40° to 70°C	20°	2°	10°	1°
12*†	0° to 100°F & -20° to 40°C	12F*†	0° to 100°F	12C*†	-20° to 40°C	10°	1°	10°	1°
03*†	25° to 125°F & -5° to 50°C	03F*†	25° to 125°F	03C*†	-5° to 50°C	10°	1°	5°	1/2°
04	0° to 200°F & -20° to 95°C	04F	0° to 200°F	04C	-20° to 95°C	20°	2°	10°	1°
05	20° to 240°F & -10° to 115°C	05F	20° to 240°F	05C	-10° to 115°C	20°	2°	10°	1°
27	0° to 250°F & -20° to 120°C	27F	0° to 250°F	27C	-20° to 120°C	50°	2°	20°	2°
06	50° to 300°F & 10° to 150°C	06F	50° to 300°F	06C	10° to 150°C	50°	2°	20°	2°
07	50° to 400°F & 10° to 200°C	07F	50° to 400°F	07C	10° to 200°C	50°	5°	50°	2°
08	50° to 500°F & 10° to 260°C	08F	50° to 500°F	08C	10° to 260°C	50°	5°	50°	2°
09*	150° to 750°F & 50° to 400°C	09F*	150° to 750°F	09C*	50° to 400°C	100°	10°	50°	5°
10*	200° to 1000°F & 100° to 550°C	10F*	200° to 1000°F	10C*	100° to 550°C	100°	10°	100°	5°

* Minimum stem length for these ranges is 4".

† Minimum insertion length for these ranges is 3".