



# DIRECTIONAL CONTROL AIR VALVES & accessories



Lapped Spool Valves  
page 1

P-Series Valves  
page 2-8

Valve Accessories  
page 9

A-Series Valves  
page 10-14

Sprite Valves  
page 15-18

Flow Control Valves  
page 19-22

Omni Series Valves  
page 23-57

316 Stainless Steel Valves  
page 58-60

Loc-Master Safety Valves  
page 61-63

Mini Bazooka Air Valves  
page 64-65

Big Bazooka Air Valves  
page 66-67

Automotive Indy Series Valves  
page 68-76

Proportional Control Valves  
page 77-80

Detroit Line Air Valves  
page 81-86



## LAPPED SPOOL VALVES

### SERIES P VALVES

The heart of the Series P valve is the packless body and spool assembly constructed of aluminum with a ceramic hard aluminum oxide finish. This unique cartridge and spool assembly is completely isolated from external forces; is pressure balanced, allowing any port to be pressurized or subjected to back pressure with no effect on shifting force, and has been designed to meet the most stringent requirements that today's customers demand. All Series P valves are inline, and all can be manifolded. This series is manufactured to the highest quality standards in the industry today and all carry a three year warranty on all parts of the valve, including the coil. No lubrication; extremely fast shifting coupled with very low minimum pilot pressure, a variety of options and all at a low cost.

#### CONSTRUCTION:

- **Body, End Caps & Manifolds:** Anodized Aluminum
- **Cartridge & Spool:** Hard Coated Aluminum
- **Coils:** Molded Nylon
- **O-Rings:** Buna N (Nitrile)

#### LUBRICATION:

**NONE REQUIRED** - However a general purpose lubricating oil may be used if desired. In these cases, we recommend ASTM/ISO viscosity Grade 32.

#### FILTRATION:

A 40 micron filter is recommended.

#### WARRANTY:

Series P valves are covered by a three year warranty from date of purchase. Series A & Sprite are covered by a 90-day warranty. All provisions of our standard warranty policy (available upon request) apply.

#### OPERATING PRESSURES:

- **Internal Pilot (Standard):** 10 P.S.I. to 150 P.S.I.
- **External Pilot:** Vacuum to 150 P.S.I.

**NOTE:** External Pilot Supply of at least 10 P.S.I. required for vacuum service.

#### MOUNTING:

All Series P Valves have no limitations as far as the orientation of the valve. Coils can be rotated in any direction for ease of installation.

#### CYCLE RATE:

Series P Valves may be cycled at over 2000 cycles per minute in most applications.

#### OPTIONS:

Include hard wired coils; factory assembly of valves to manifolds; a variety of plug connectors; pre-installed AQ push-in fittings, and many other popular options.



Series P Spool Assembly



### SERIES A & SPRITE VALVES

Alkon Series A and Sprite II valves have been designed to comply with the ever more stringent requirements for increased production rates through higher speeds and component reliability. The heart of these valves is a packless spool body and spool assembly constructed of aluminum with a ceramic hard aluminum oxide finish. Ground and matched to precision tolerances, its operation is virtually frictionless.

Benefits of this packless design begin with the elimination of dynamic seals and their incumbent difficulties. Fast response allows increased machine cycle rates; non-lube operation reduces scheduled maintenance requirements. The body and spool assembly is pressure balanced, allowing any port to be pressurized or subjected to back pressure with no effect on spool shifting force. Exhaust port mufflers or speed controls may be used with no effect on valve response.

The unique body and spool assembly has been completely isolated from external forces by use of a patented 3-point suspension. This assembly, coupled with a complete variety of actuators and mounting alternatives, provides the highest level of performance and versatility found in the air valve industry.



#### VALVE FEATURES

- Packless design
- Fast Response
- Operate with or without lubrication
- Can be subbase, manifold or cylinder mounted



**ALKON**

PFW .085 Cv  
PMW .160 Cv

## SERIES P-FW/MW MINIATURE 3-WAY VALVES

### GENERAL INFORMATION:

- Anodized Aluminum Body for a corrosion resistant, lightweight package
- Mount as a single station valve or stack into a manifold of up to 15 stations
- Options include hard wired coils, non-locking manual override and a variety of plug connectors
- Can easily be converted to a two-way valve simply by plugging the exhaust port
- Coils can be rotated in 90° increments
- Choice of two flow models



### SPECIFICATIONS:

- Operating Temperature: 0° to 125°
- Operating Pressure: Vacuum to 150 P.S.I.
- Cv Rating:  
FW Cv .085 (Approx. 4 SCFM)  
MW Cv .16 (Approx. 8 SCFM)
- Weight: Approximately 4.3 oz
- Normally closed

### FEATURES:

- Choice of 1/8 NPT or 1/4 NPT
- Standard Locking Type Manual Override
- Direct Acting Solenoid
- Three Year Warranty
- Bottom mounting holes

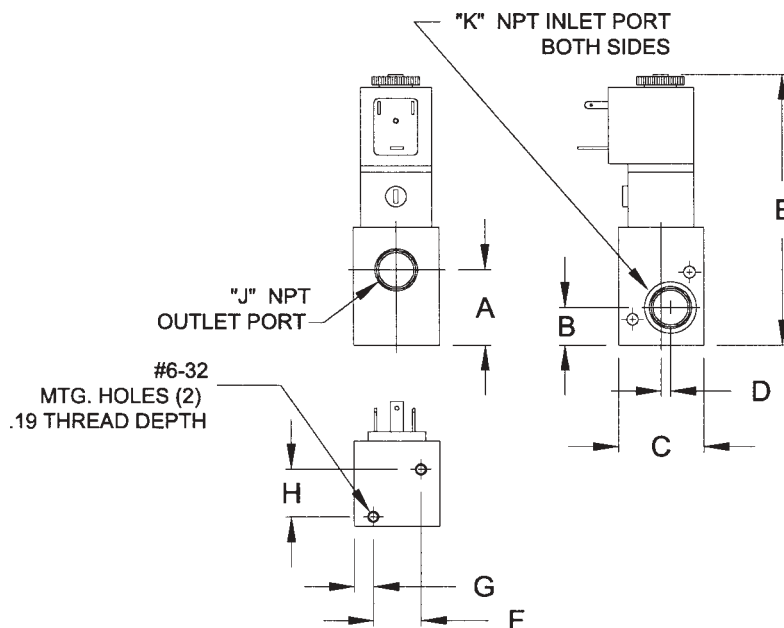

### SERIES P-FW/MW MINIATURE 3-WAY VALVES

| PART #    | A     | B    | C     | Sq.  | D    | E     | F    | G    | H    | J       | K       |
|-----------|-------|------|-------|------|------|-------|------|------|------|---------|---------|
| P-FW1/MW1 | .766  | .422 | 1.000 | .094 | .094 | 3.250 | .562 | .125 | .500 | 1/8 NPT | 1/8 NPT |
| P-FW2/MW2 | 1.000 | .500 | 1.125 | .125 | .125 | 3.593 | .625 | .125 | .625 | 1/4 NPT | 1/4 NPT |

### SIMPLE HOW-TO-ORDER INSTRUCTIONS

| P-     | FW1   | SS       | 115/60        | NL                          |
|--------|-------|----------|---------------|-----------------------------|
| SERIES | MODEL | FUNCTION | VOLTAGE       | OPTIONS                     |
| P      | FW1   | SS       | 6 VDC 24/60   | NL - Non Locking Override   |
|        | FW2   |          | 12 VDC 115/60 | N4 - Nema 4 Operator        |
|        | MW1   |          | 24 VDC 230/60 | FA - Factory Assembly Stack |
|        | MW2   |          |               | (Specify # of Stations)     |

Plug Connections: See P-070/140 on Page 7



# SERIES P-MC 3-WAY VALVES

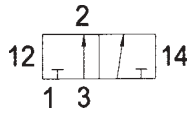

## GENERAL INFORMATION

- Compact size
- Variety of combinations
- In line design - or mount on manifold
- Normally open or normally closed models
- 1/8 NPT or 1/4 NPT ports
- Cv - .5 (1/8") or .85 (1/4")
- Cycle Rate - Up to 2,500 per minute
- Standard locking manual override

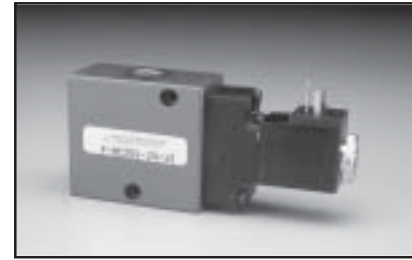

## SIMPLE HOW-TO-ORDER INSTRUCTIONS

| P-M    | C                  | 1                          | SS                                    | 115/60  | HW   |
|--------|--------------------|----------------------------|---------------------------------------|---|--|
| SERIES | TYPE               | SIZE                       | FUNCTION                              | VOLTAGE                                       | OPTIONS  |
| P      | MC (NC)<br>MO (NO) | 1 (1/8 NPT)<br>2 (1/4 NPT) | SS-Single Solenoid<br>SP-Single Pilot | 6 VDC 24/60<br>12 VDC 115/60<br>24 VDC 230/60 | HW - Hard Wire Coil Leads<br>FA - Factory Assembly of Manifolds<br>XP - External Pilot Supply Port |

**MANIFOLDS:** Available from 2 to 10 stations

P-MC1: Part # 22029 - (# of stations)

P-MC2: Part # 22046 - (# of stations)

**BLOCKING PLATE:** To block off manifold station

P-MC1: Part # 22060

P-MC2: Part # 22061

**LOW WATTAGE SOLENOID:**

Consult factory

**SURGE SUPPRESSORS:**

Consult factory

**CONNECTORS:**

Part # 21876: Standard Connector

Part # 21878: Standard Connector  
with pre-wired 3 ft. leads

Part # 21905 - ( ): Lighted Connector (Voltage)

Part # 21906 - ( ): Lighted Connector (Voltage)  
with pre-wired 3 ft. leads

Part # 22076: Standard Connector  
with pre-wired 6 ft. leads

**USE FOLLOWING VOLTAGE CODES:**

For lighted connectors

6 VDC - 01      12 VDC - 02      24 VDC - 03

24/60 - 05      115/60 - 06      230/60 - 07

## DIMENSIONS

| MODEL# | A | B | C | D | E | F | G | H | J | K | L |
|--------|---|---|---|---|---|---|---|---|---|---|---|
|--------|---|---|---|---|---|---|---|---|---|---|---|

|       |      |      |       |      |      |      |       |      |      |      |     |
|-------|------|------|-------|------|------|------|-------|------|------|------|-----|
| P-MC1 | .961 | 4.25 | 1.188 | 1.56 | .961 | .500 | 1.75  | .750 | .218 | .266 | 1/8 |
| P-MC2 | .961 | 4.25 | 1.375 | 1.88 | .961 | .500 | 1.875 | 1.00 | .200 | .400 | 1/4 |

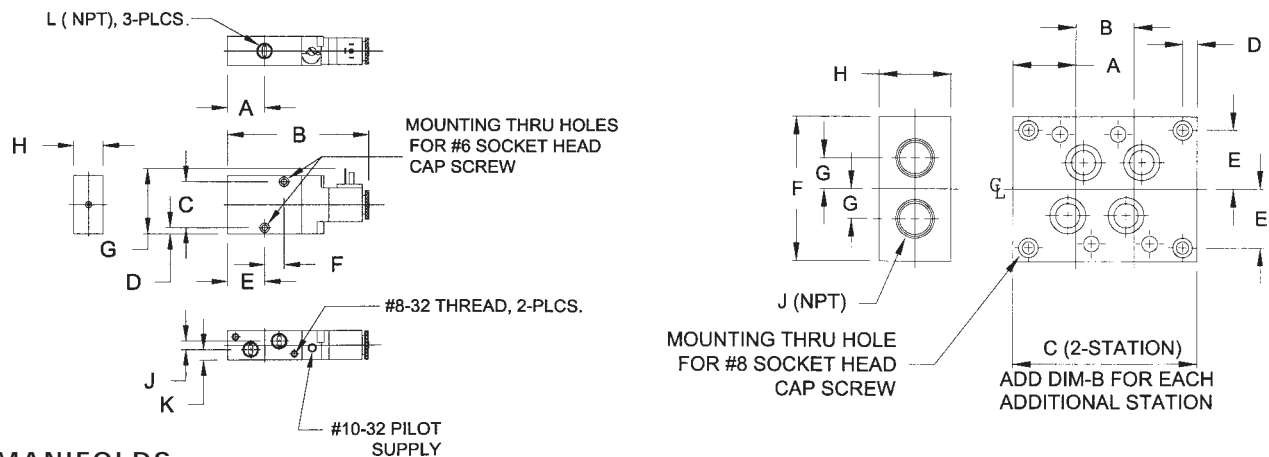

## MANIFOLDS

| MODEL# | A | B | C | D | E | F | G | H | J |
|--------|---|---|---|---|---|---|---|---|---|
|--------|---|---|---|---|---|---|---|---|---|

|       |      |       |       |      |      |      |      |      |     |
|-------|------|-------|-------|------|------|------|------|------|-----|
| P-MC1 | .875 | .812  | 2.562 | .200 | .812 | 2.00 | .415 | 1.00 | 1/4 |
| P-MC2 | .968 | 1.063 | 3.00  | .188 | .812 | 2.00 | .415 | 1.00 | 1/4 |



# ALKON

## SERIES P-035 4-WAY VALVES

- 1/8 NPT Ports
- Cv - .4
- Cycle rate - Up to 2,500 per minute
- Standard locking manual overdrive

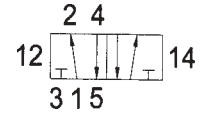

### SIMPLE HOW-TO-ORDER INSTRUCTIONS

| P-     | 035   | SS                                    | 115/60  | HW      |                                    |
|--------|-------|---------------------------------------|---------|---------|------------------------------------|
| SERIES | MODEL | FUNCTION                              | VOLTAGE | OPTIONS |                                    |
| P      | 035   | SS (Single Solenoid)                  | 6 VDC   | 24/60   | HW - Hard Wire Coil Leads          |
|        |       | DS (Double Solenoid)                  | 12 VDC  | 115/60  | FA - Factory Assembly of Manifolds |
|        |       | SP (Single Pilot)                     | 24 VDC  | 230/60  | XP - External Pilot Supply Port    |
|        |       | DP (Double Pilot)                     |         |         |                                    |
|        |       | 3S (3 POS., DS,<br>all ports blocked) |         |         |                                    |
|        |       | 3P (3 POS., DP,<br>all ports blocked) |         |         |                                    |

**MANIFOLDS:** Available from 2 to 10 stations

Part # 21904 - (# of stations)

**BLOCKING PLATE:** To block off manifold station

Part # 21908

**INTERFACE PLATE:** For mounting a P-035 to a

P-070 manifold - Part # 21910

**CONNECTORS:**

Part # 21876: Standard Connector

Part # 21878: Standard Connector

with pre-wired 3 ft. leads

Part # 21905 - ( ): Lighted Connector (Voltage

Part # 21906 - ( ): Lighted Connector (Voltage

with pre-wired 3 ft. leads

Part # 22076: Standard Connector

with pre-wired 6 ft. leads)

**LOW WATTAGE SOLENOID:**

Consult factory

**SURGE SUPPRESSORS:**

Consult factory

**USE FOLLOWING**

**VOLTAGE CODES:**

For lighted connectors

6 VDC - 01      12 VDC - 02      24 VDC - 03

24/60 - 05      115/60 - 06      230/60 - 07



# SERIES P-070 / P-140 4-WAY VALVES

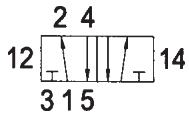

## GENERAL INFORMATION:

- High flow Multi-Purpose Design
- Use as a 3 Way by plugging one port
- In line design - or mount on manifold
- Single or double solenoid or pilot
- Two or three position models available

- P-070: 1/4" Ports Cv - .8
- P-140: 3/8" Ports Cv - 1.5
- Cycle Rate - over 2,000 per minute
- Standard non-locking manual override
- Wide variety of popular options



## P-070 Hand Lever Valve

Part # P-070-HL

The P-070 is available in a Hand Lever Version that is compact and versatile. The standard is a spring return model that may be converted to a detented model simply by turning two allen screws in the end cap.

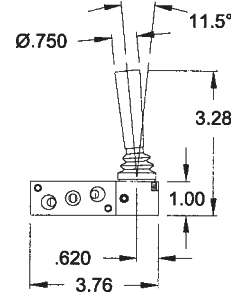

## SIMPLE HOW-TO-ORDER INSTRUCTIONS

| P-     | 070   | SS                                 | 115/60  | HW      |                                    |
|--------|-------|------------------------------------|---------|---------|------------------------------------|
| SERIES | MODEL | FUNCTION                           | VOLTAGE | OPTIONS |                                    |
| P      | 070   | SS (Single Solenoid)               | 6 VDC   | 24/60   | HW - Hard Wire Coil Leads          |
|        | 140   | DS (Double Solenoid)               | 12 VDC  | 115/60  | FA - Factory Assembly of Manifolds |
|        |       | SP (Single Pilot)                  | 24 VDC  | 230/60  | XP - External Pilot Supply Port    |
|        |       | DP (Double Pilot)                  |         |         | LM - Locking Manual Override       |
|        |       | 3S (3 POS., DS, all ports blocked) |         |         | N4 - NEMA 4 Operator               |
|        |       | 3P (3 POS., DP all ports blocked)  |         |         |                                    |

Consult factory for other available combinations

### MANIFOLDS:

Available from 2 to 10 stations  
P-070: Part # 21821 - (# of stations)  
P-140: Part # 21907 - (# of stations)

### BLOCKING PLATE:

To block off manifold station  
P-070: Part # 21822  
P-140: Part # 21909

### SURGE SUPPRESSORS:

Consult factory

## CONNECTORS:

- Part # 21823: Standard Connector
- Part # 21839: Standard Connector with pre-wired 3 ft. leads
- Part # 21824 - ( ): Lighted Connector (Voltage)
- Part # 21840 - ( ): Lighted Connector (Voltage) with pre-wired 3 ft. leads
- Part # 21852: 1/2 NPT Conduit Connector
- Part # 21841 - ( ): Connector (Voltage) with molded 3 ft. leads
- Part # 21842 - ( ): Lighted Connector (Voltage) with molded 3 ft. leads
- Part # 22078: Standard Connector with pre-wired 6 ft. leads

## USE FOLLOWING VOLTAGE CODES:

For lighted connectors  
6 VDC - 01      12 VDC - 02      24 VDC - 03  
24/60 - 05      115/60 - 06      230/60 - 07



# ALKON

## SERIES P - 4 WAY VALVES

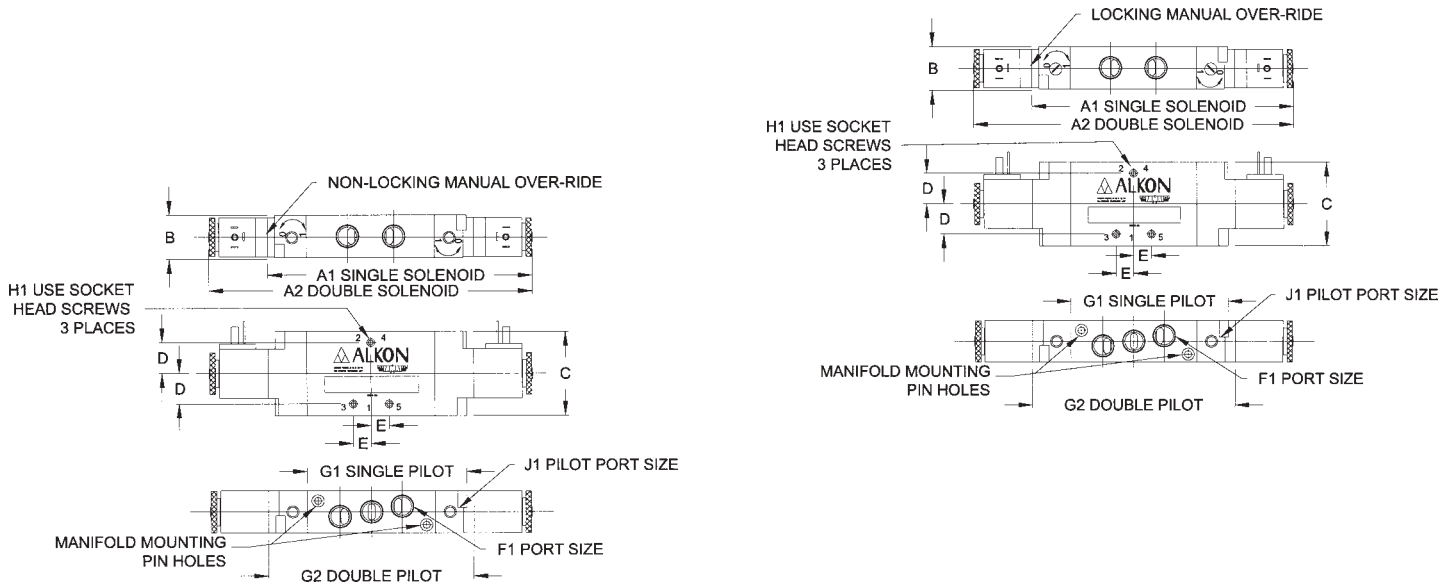

### DIMENSIONS

| MODEL# | A1   | A2   | B    | C    | D    | E    | F1      | G1   | G2   | H1 | J1    |
|--------|------|------|------|------|------|------|---------|------|------|----|-------|
| P-035  | 4.58 | 6.88 | .750 | 1.50 | .594 | .325 | 1/8 NPT | 2.77 | 3.26 | #4 | 10-32 |
| P-070  | 5.16 | 7.80 | 1.00 | 2.00 | .750 | .359 | 1/4 NPT | 3.14 | 3.75 | #6 | 1/8   |
| P-140  | 6.01 | 8.77 | 1.25 | 2.50 | 1.00 | .435 | 3/8 NPT | 3.99 | 4.73 | #8 | 1/8   |

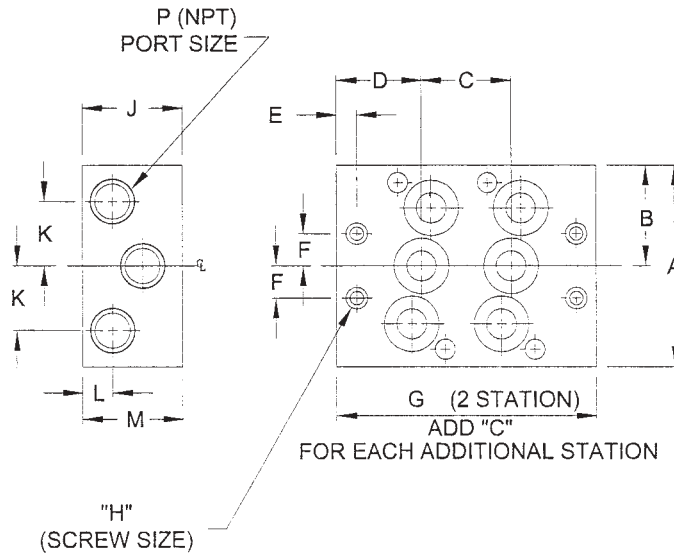

### MANIFOLDS

| MODEL# | PART# | A    | B    | C     | D     | E    | F    | G     | H   | J     | K    | L    | M     | P   |
|--------|-------|------|------|-------|-------|------|------|-------|-----|-------|------|------|-------|-----|
| P-035  | 21904 | 2.50 | 1.25 | .812  | .938  | .250 | .390 | 2.688 | #6  | 1.000 | .781 | .344 | .656  | 1/4 |
| P-070  | 21821 | 2.50 | 1.25 | 1.125 | 1.062 | .250 | .400 | 3.250 | #8  | 1.250 | .800 | .500 | .875  | 1/4 |
| P-140  | 21907 | 3.00 | 1.50 | 1.375 | 1.344 | .344 | .461 | 4.062 | #10 | 1.750 | .922 | .594 | 1.156 | 3/8 |

### MANIFOLD ASSEMBLY:

Manifolds can be purchased separately or valves can be assembled to them at the factory.

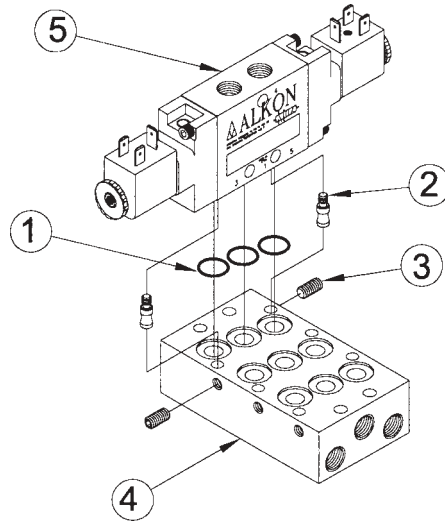

Hardened mounting pins (2) are screwed into the valve body (5) until flush, and then the valve unit is inserted into the manifold block (4) after positioning the o-rings (1). By tightening the allen head screws (3), the valves are seated and connected to the manifold block. This unique method assures a leak proof assembly. When manifolds are purchased separately, each kit contains mounting pins, set screws and o-rings for the purchased number of stations.

### CONNECTORS:

In addition to the standard connectors and coils shown (see individual valve packages for part numbers), we also offer custom configurations such as different length cords, lighted wafers, light adapters, green or red LED's, and a variety of others. Contact your local Alkon distributor for more information.



### ELECTRICAL CHARACTERISTICS

| VOLTAGE | INRUSH (AMPS) | HOLDING (AMPS) | NOMINAL POWER CONSUMPTION |
|---------|---------------|----------------|---------------------------|
| 6VDC    | .240          | .240           | 2.9W                      |
| 12VDC   | .240          | .240           | 2.9W                      |
| 24VDC   | .108          | .108           | 2.6W                      |
| 24/60   | .340          | .210           | 3.8W                      |
| 115/60  | .070          | .044           | 3.8W                      |
| 230/60  | .040          | .024           | 3.8W                      |

### RESPONSE

| MODEL TYPE | TIME TO ENERGIZE | TIME TO DE-ENERGIZE |
|------------|------------------|---------------------|
| A.C. SOL.  | 7 MS             | 18 MS               |
| D.C. SOL.  | 10 MS            | 18 MS               |
| PILOT      | 6 MS             | N/A                 |

### REPLACEMENT COILS

| VOLTAGE | P-035 - P-MC |           | P-070/140 - P-FW |           | P-MW     |           |
|---------|--------------|-----------|------------------|-----------|----------|-----------|
|         | STANDARD     | HARD WIRE | STANDARD         | HARD WIRE | STANDARD | HARD WIRE |
| 6 VDC   | 21874-01     | 21875-01  | 21832-01         | 21833-01  | 22071-01 | 22065-01  |
| 12 VDC  | 21874-02     | 21875-02  | 21832-02         | 21833-02  | 22071-02 | 22065-02  |
| 24 VDC  | 21874-03     | 21875-03  | 21832-03         | 21833-03  | 22071-03 | 22065-03  |
| 24/60   | 21874-05     | 21875-05  | 21832-05         | 21833-05  | 22071-05 | 22065-05  |
| 115/60  | 21874-06     | 21875-06  | 21832-06         | 21833-06  | 22071-06 | 22065-06  |
| 230/60  | 21874-07     | 21875-07  | 21832-07         | 21833-07  | 22071-07 | 22065-07  |



# ALKON

## SERIES PM 3-WAY VALVES

Normally Closed, 10/32" Ports, Toggle; Push Button; Cam Actuators, and a Variety of Porting Options

### GENERAL INFORMATION:

#### MATERIALS

BODY: Anodized Aluminum  
STEM: Acetal  
SPRING: Stainless Steel  
BUTTONS/TOGGLES: Nylon  
SEALS: Buna-N

#### OPERATING PRESSURE

0 TO 125 P.S.I. Air

#### OPERATING TEMPERATURE

-20F To + 160F (-28C to + 71C)

#### FUNCTION

3-Way, Normally Closed

#### FLOW RATE

Approximately 10 SCFM  
at 100 P.S.I.

#### ACTUATING FORCE

2 lbs. to 3.5 lbs.

#### PORTING

INLET: Bottom Port  
OUTLET: Port nearest inlet  
EXHAUST: Port nearest actuator

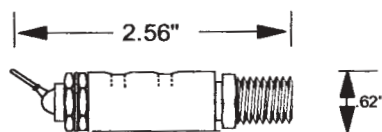

PM-3H-01(Detented)  
PM-3F-01(Spr. Ret.)

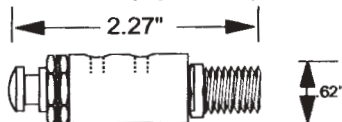

PM-3A-01

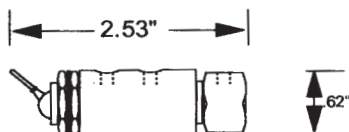

PM-3H-02(Detented)  
PM-3F-02(Spr. Ret.)

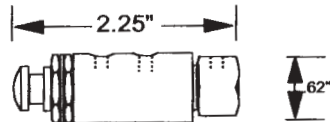

PM-3A-02

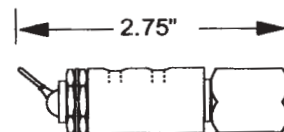

PM-3H-04(Detented)  
PM-3F-04(Spr. Ret.)

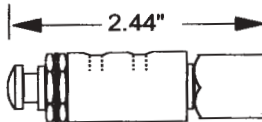

PM-3A-04

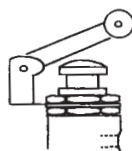

#### Cam Actuator

Part # PM-CA-1

Acetal roller on a nickel plated arm.  
Mounts to any push button (above)  
with 5/64" spacer - other types are  
available.

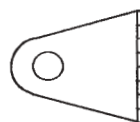

#### Right Angle Mounting Bracket

Part # PM-MB-1

Use to mount any PM Series Valve.  
Also available in a flat version.

# VALVE ACCESSORIES

The dual exhaust and balanced design of the Alkon valve allows for the use of inexpensive exhaust metering valves. When screwed into the exhaust ports, they independently control the actuator speed in either or both directions.

Metering valves have aluminum bodies and steel adjusting screws.

Mufflers are used to silence the noise caused by exhausting air. Both standard mufflers and speed control mufflers are made of brass and sintered bronze.

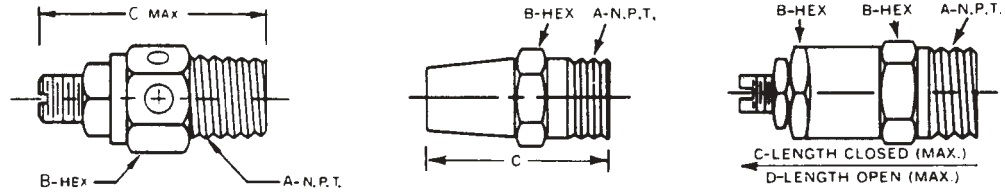

| MODEL No. | DESCRIPTION                   | Wt.     | DIMENSIONS |       |       |       | Cv FACTOR | SERIES ISI PART No. |
|-----------|-------------------------------|---------|------------|-------|-------|-------|-----------|---------------------|
|           |                               |         | A          | B     | C     | D     |           |                     |
| 6661      | 1/4 NPT Metering Valve        | 1/2 oz. | 1/4        | .562  | 1.437 | -     | 1.00      | ER25                |
| 7985      | 3/8 NPT Metering Valve        | 1 oz.   | 3/8        | .687  | 1.812 | -     | 1.55      | ER37                |
| ER-50     | 1/2 NPT Metering Valve        | 4 oz.   | 1/2        | .875  | 2.0   | -     | 1.75      | ER-50               |
| 40A01081  | #10-32 Exhaust Breather       | 1/2 oz. | 10-32      | .312  | .40   | -     | .20       | 40A01081            |
| 9516-1    | 1/8 NPT Muffler               | 1 oz.   | 1/8        | .437  | 1.125 | -     | .52       | MF18M               |
| 9516-2    | 1/4 NPT Muffler               | 2 oz.   | 1/4        | .562  | 1.375 | -     | 1.10      | MF14M               |
| 9516-3    | 3/8 NPT Muffler               | 3 oz.   | 3/8        | .687  | 1.500 | -     | 1.60      | MF38M               |
| 9516-4    | 1/2 NPT Muffler               | 4 oz.   | 1/2        | .875  | 1.875 | -     | 3.20      | MF12M               |
| 9516-6    | 3/4 NPT Muffler               | 5 oz.   | 3/4        | 1.062 | 2.250 | -     | 5.10      | MF34M               |
| 9516-8    | 1 NPT Muffler                 | 6 oz.   | 1          | 1.312 | 2.875 | -     | 10.0      | MF100M              |
| 9564-1    | 1/8 NPT Speed Control Muffler | 2 oz.   | 1/8        | .562  | 1.375 | 2.000 | .59       | SCS-18              |
| 9564-2    | 1/4 NPT Speed Control Muffler | 3 oz.   | 1/4        | .625  | 1.562 | 2.187 | .77       | SCS-14              |
| 9564-3    | 3/8 NPT Speed Control Muffler | 4 oz.   | 3/8        | .687  | 1.875 | 2.813 | 1.31      | SCS-38              |
| 9564-4    | 1/2 NPT Speed Control Muffler | 5 oz.   | 1/2        | .875  | 2.250 | 3.312 | 2.60      | SCS-12              |
| SCS-34    | 3/4 NPT Speed Control Muffler | 7 oz.   | 3/4        | 1.062 | 2.375 | -     | 4.80      | SCS-34              |
| SCS-100   | 1 NPT Speed Control Muffler   | 9 oz.   | 1          | 1.312 | 2.500 | -     | 8.50      | SCS-100             |

# SERIES A VALVES

## Solenoid Controlled / Pilot Operated

Reliably rapid response is inherent to the Series A valve's design concept. The low friction operation, short spool travel and low mass spool all represent construction features that make fast response possible.

Equally important, this fast response is repeatable. It does not fluctuate when degree of lubrication, operating pressure or internal valve back pressure vary.

Fast, repeatable response translates into immediate benefits for the machine designer. Now, machine cycle rates can be increased to match the valve's instant response to control signals.

## Horizontal and Vertical Solenoid Operation

Solenoid/Pilot operators are available in either horizontal or vertical configurations to accommodate varying space limitations.

The horizontal model is usually used for sub-base and cylinder mounting; the vertical for manifold mounting since it provides access to the manifolds side cylinder ports.

Series A solenoid operators offer a wide variety of voltages and frequencies; all coils are continuously rated, and continuous cycle rates up to 300 CPM can be maintained.

### Options

- Molded coils
- Locking type manual override
- Two position detent (adds 5/8" to overall length)
- 1/4 NPT threaded pilot exhaust adapter
- External pilot supply

NOTE: Three position open or closed center valves are available as special assemblies. Consult factory.



Model 7900, Single Horizontal Solenoid/Pilot Operated



Model 7980, Double Horizontal Solenoid/Pilot Operated



Model 8060, Single Vertical Solenoid/Pilot Operated



Model 8065, Double Vertical Solenoid/Pilot Operated

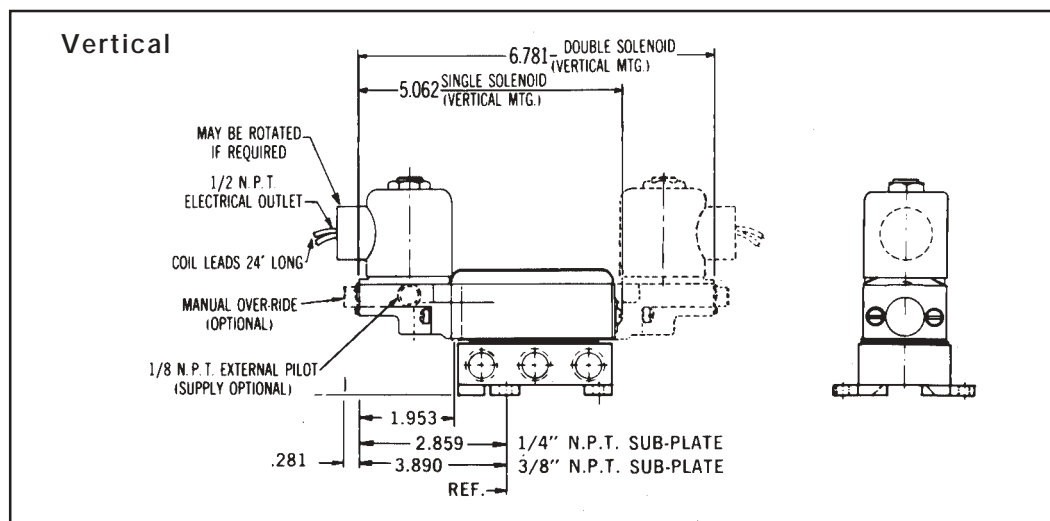
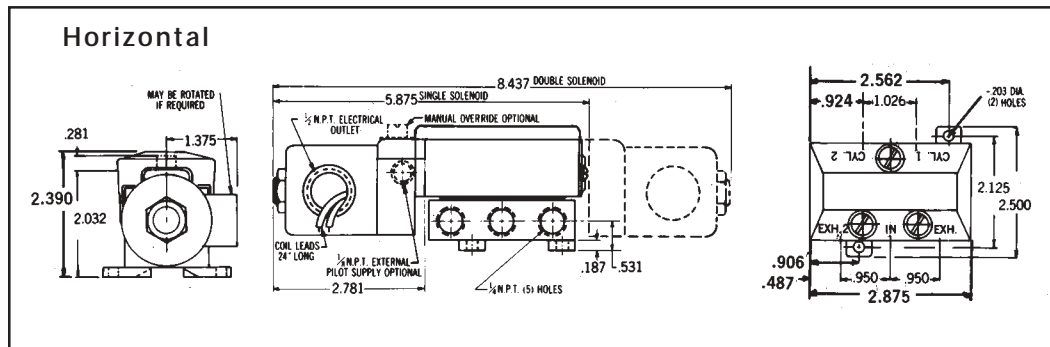

## SERIES A VALVES

### Sprite Valve Actuator

SPRITE solenoid/pilot operators are available for single or double actuation applications in horizontal configurations.

The SPRITE actuator offers lapped -spool reliability in both valve and operator, providing a maintenance-free product life measured in multi-millions of cycles currently unobtainable from standard pilot/solenoid operators.

Offered in a wide variety of voltages and frequencies; all coils are rated for continuous or maintained signal service and continuous repeatable cycle rates in excess of 3000 CPM are possible. Molded coils are standard and solenoid housings meet most JIC and NEMA IV criteria. Non-locking manual override is standard.

#### Options

- Two position detent (adds 5/8" to overall length)

NOTE: Three position open or closed center valves are available as special assemblies. Consult factory.



Model A 7902,  
Single Solenoid  
Pilot Operated



Model A 7982,  
Double Solenoid  
Pilot Operated



Model 7984  
Single Pilot  
Operated



Model 7986  
Double Pilot  
Operated

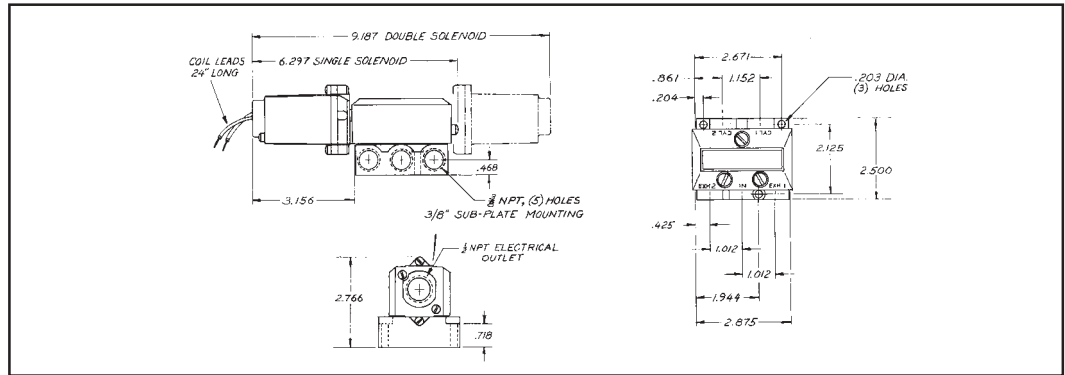

### Air Pilot

In applications where electrical controls are not suitable, or where they are hazardous, air pilot operated valves can be used. These valves can also be applied for special purpose circuitry such as sequencing or timing operations.

Since the low friction characteristics of the body and spool assembly requires only .50 psig to shift, vacuum can be considered as a signal source. Air pilot operated valves, do however require external valves to supply the required signal pressure.

#### Options

- Two position detent (adds 5/8" to overall length)

NOTE: Three position open or closed center valves are available as special assemblies. Consult factory.

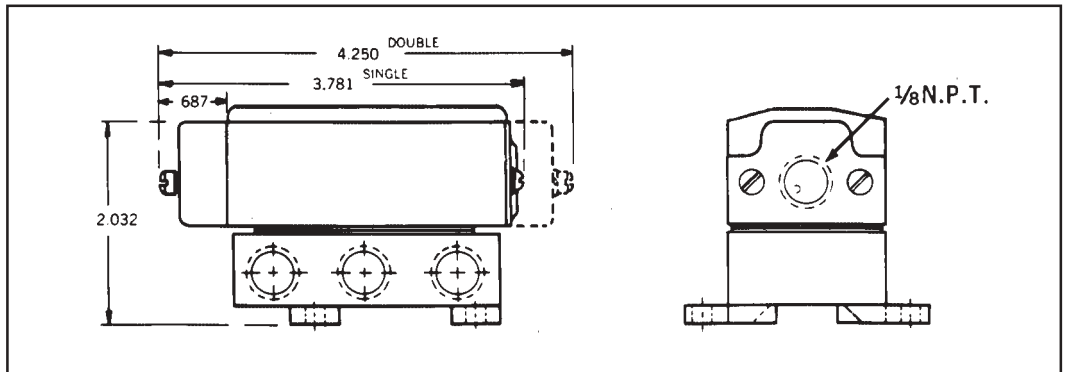



# ALKON

## SERIES A VALVES

### Air Bleeder Operated

#### Bleeder Operated

Both air pilot and bleeder operated valves can be applied when electrical control is impractical or hazardous. The bleeder can be used in place of the air pilot model where limited space prohibits the external pilot pressure supply required by the external pilot control valves.

#### Bleeder Operators

#6000, Plunger type bleeder operator is used when striking force is straight on.

#8492, Ball type bleeder operator has a hardened ball for cam actuation.

#### Options

- Two position detent (adds 5/8" to overall length)



Model 7919  
Air Bleeder Operated

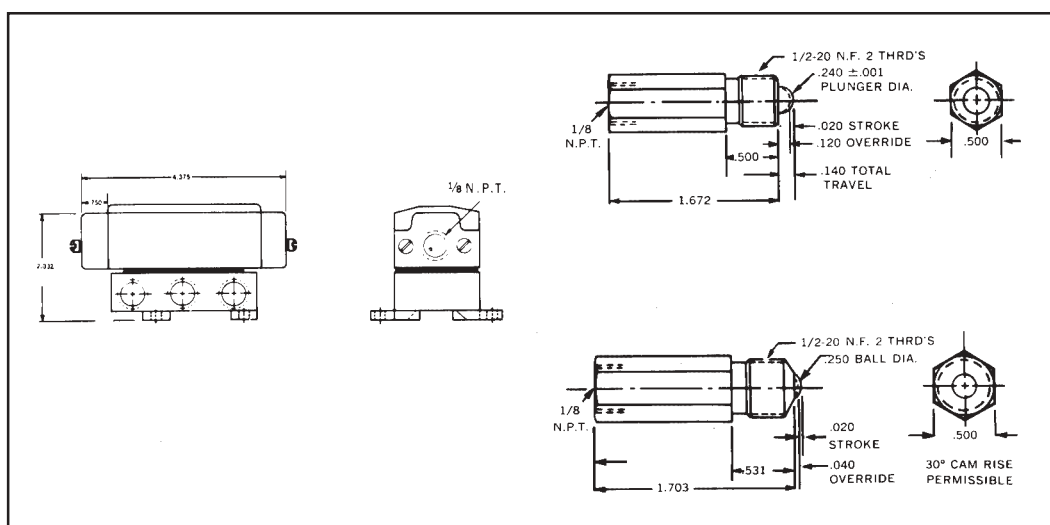

### Integrated Power Package

The integrated power package is a subbase assembly in which the Series A valve is assembled directly to any square head tie rod type air cylinder.

Since only one air supply connection is required, assembly times can be greatly reduced. AC sub-bases include metering valves and muffler to keep the Integrated Power Package a neat, compact cylinder and valve combination. The AC valve increases the overall height of the cylinder by only 3 inches.

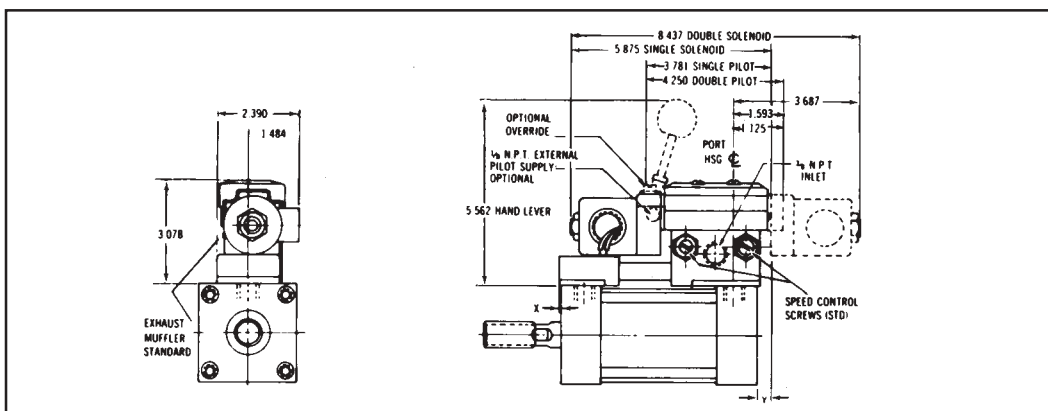





# ALKON

## SERIES A VALVES

### Solenoid / Pilot Valve Specifications

- Operating Pressure (std.): 20 - 175 psig
- Operating Pressure (with optional external pilot supply: Vacuum - 250 psig)
- Maximum allowable cycle rate: 300 CPM (to 600 CPM under specified conditions)
- Maximum heat rise: 85°C

#### Response Characteristics

| Size     | Model Type  | Time to Shift in Milli-Seconds* | Time to Fill 10 in <sup>3</sup> Chamber to 80 PSI | De-energization |                    |
|----------|-------------|---------------------------------|---|-----------------|--------------------|
|          |             |                                 |   | Start to Unload | Unload to 20 PSI** |
| 1/4"     | Single Sol. | 9                               | 22  | 22              | 33                 |
| Sub-base | Double Sol. | 9                               | 20  | 10              | 30                 |
| 3/8"     | Single Sol. | 9                               | 21  | 20              | 31                 |
| Sub-base | Double Sol. | 9                               | 19  | 10              | 29                 |

For models A7902 and A7982 refer to SPRITE II

#### Electrical Characteristics

| Voltage | Inrush (Ma) | Holding (Ma) | Nominal Power Consumption |
|---------|-------------|--------------|---------------------------|
| 6VDC    | -           | 1830         | 12 watts                  |
| 12VDC   | -           | 790          | 12 watts                  |
| 24VDC   | -           | 396          | 12 watts                  |
| 24/60   | 1250        | 835          | 12 watts                  |
| 115/60  | 261         | 174          | 12 watts                  |
| 230/60  | 130         | 87           | 12 watts                  |

### General Specifications

#### Flow Characteristics

Airline Preparation: The Series A valve may be used with dry or lubricated filtered air.

Installation: Valve body to sub-base screws should be torqued no more than 24 in./lb.

Flow curves shown are for the 1/4" sub-base mounted valves. For 3/8" sub-base, 1/4" or 3/8" manifold valves use the noted correction factors, (CF).

\* Represents time in milliseconds from solenoid actuation to first recorded pressure in chamber. At cylinder port itself, solenoid pilot valves required a maximum of 8 milliseconds.

\*\* Represents time from first recorded pressure decay in chamber to unloading down to 20 psig from 100 psig initial pressure.

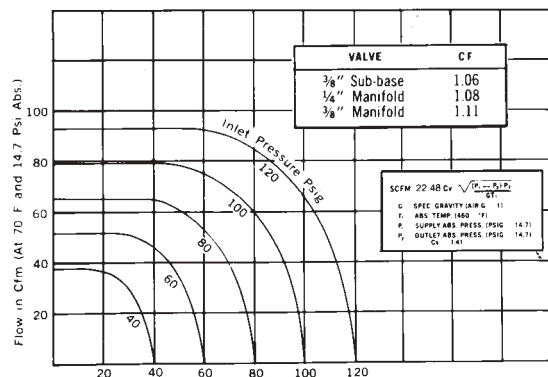

#### CV Values

| Mounting Type | CV Valve |
|---------------|----------|
| 1/4" Sub-base | 1.41     |
| 3/8" Sub-base | 1.49     |
| 1/4" Manifold | 1.52     |
| 3/8" Manifold | 1.57     |

### How To Order Series A Valves

| A                                      | A                   | 7900                          | 3/8           | 115/60                          | MC                | Code |
|--|---------------------|-------------------------------|---------------|---------------------------------|-------------------|------|
| Series "A" Pneumatic Directional Valve | Mounting            | Valve Model (See Pages 10-13) | Size          | Voltage (If Applicable Specify) | Options           |      |
|  | A Sub-base          |                               | Sub-base 1/4" |                                 | 2 Position Detent | 2P   |
|  | M Multiple-Manifold |                               | 3/8"          |                                 | External Pilot    | XP   |
|  | C Cylinder          |                               | Multiple 1/4" |                                 | Exhaust Adp.      | EA   |
|  |                     |                               | Manifold 3/8" |                                 | Molded Coil       | MC   |
|  |                     |                               | Cylinder 1/8" |                                 | Less Sub-base     | LS   |
|  |                     |                               | Mounted 1/4"  |                                 | Less Coil         | LC   |
|  |                     |                               | Valves 3/8"   |                                 | Manual Override   | MO   |
|  |                     |                               | 1/2"          |                                 |                   |      |

Notes:

- Valves as ordered above will be shipped assembled to sub-base or manifold called out.
- If no base is required specify option code LS in appropriate area of model number.
- If coil voltage is not specified, std. 115/60 will be furnished.
- Cylinder mount Subbase is furnished with 12" transfer tube as standard.



## SPRITE VALVES

### 3 & 4 Way Air Valves That Bring a New Concept to Air Valve Design



The Sprite II is truly a unique miniature solenoid air valve. It brings a technology to pneumatic control that through the years has proven on-the-job reliability in the small electrical relay field. This proven technology of solenoid actuation, and Alkon's time tested lapped spool valve elements combine as the basis of the exciting Sprite II valve.

The Sprite II valve has been specifically designed to bring a higher level of reliability to pneumatic equipment, and at the same time a new level of versatility to system design.

- Sub-base mounted. Same valve assembly may be used alone on its own sub-base or in compact multifunction manifolds.
- Simple operation.
- Operates with or without line lubrication.
- Working pressures to 125 psi.
- Continuous duty solenoids.
- Integral locating pin for fool-proof valve alignment to sub-base or manifold.
- Simple sub-base mounting from top or bottom.

### An Incredible Response Time and Cycle Rate

Amazing as it seems, the Sprite II valve can be continuously cycled as fast as alternating current itself - thirty-six hundred times per minute. Of course, that's far beyond practical cylinder speed, but it does make a point about the valves capabilities.

Equally impressive is the response time - from closed to full open in just 6.0 milliseconds. That in itself is quite out of the ordinary.

### Simple, Wear-free Operation

The extraordinary performance of Sprite II valves is made possible by two major characteristics:

1. Exceedingly simple operation that eliminated points of wear or fatigue.
2. A virtually frictionless precision matched body and spool assembly that requires only minimal force to shift.

The solenoid operator itself consists of a lightly hinged mechanical operating arm (armature) that's held in position by a low tension spring. With the armature in its spring held position, a second light spring holds the spool in its normal position. When the solenoid is energized, the current creates a magnetic effect on a protruding steel core, which in turn draws the armature toward it. When the solenoid is de-energized, spring force returns the pressure balanced spool to its original position.

The mass of the Sprite II armature is negligible compared to conventional T-bar or poppet type. This low mass plus the small, highly efficient magnetic gap give the Sprite II its exceptional performance characteristics.

### How To Order Sprite II Valves

| 2          | 39                 |                    | R2                                 | 115/60        | 45      |                             |
|------------|--------------------|--------------------|------------------------------------|---------------|---------|-----------------------------|
| Series "2" | VALVE FUNCTION     |                    | Single Solenoid Spring Return "R2" | VOLTAGE       | OPTIONS |                             |
|            | When Sub-Base Mtd. | When Manifold Mtd. |                                    |               | MM      | Multiple Manifold           |
| "30"       | Not Used           | 3-Way; N.C.        |                                    | 6VDC          | 4S      | 1/4" Side Ported Sub-Base   |
| "39"       | 3-Way N.C. & N.O.  | 3-Way; N.O.        |                                    | 12VDC         | 4B      | 1/4" Bottom Ported Sub-Base |
|            | Multi-Function     |                    |                                    | 24VDC         | 8S      | 1/8" Side Ported Sub-Base   |
| "40"       | 4-Way              | 4-Way              |                                    | 12V/50-60 Hz  | 8B      | 1/8" Bottom Ported Sub-Base |
|            |                    |                    |                                    | 24V/50-60 Hz  |         |                             |
|            |                    |                    |                                    | 115V/50-60 Hz |         |                             |
|            |                    |                    |                                    | 230V/50-60 Hz |         |                             |

**Note:**

- Non-Locking Manual Overrides - Standard
- Valves and bases will be shipped separately unless "Factory assembly" is specified on the order.



**ALCON**

## SPRITE VALVES

### It Has Construction Extras, Too

Sprite II is simply an outstanding valve package designed and constructed with a lot of attention to detail, like the spool which is precision machined to form extremely sharp land edges. This in turn gives the valve self-cleaning properties and reduces the stroke required for full flow.

You'll notice, too, that the spool and body are designed as a floating sub-assembly within the valve's protective housing to keep exterior forces from disturbing its precision operation.

The solenoid cover itself meets the latest industry standards - remove it and the solenoid comes with it, rendering the valve inoperative. Captive assembly bolts eliminate the possibility of lost parts in disassembly.

Complete corrosion resistance with aluminum and plated steel internal parts. One hundred percent functional testing of every valve that leaves the factory.

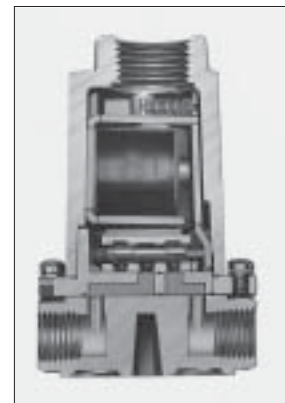

### Specifications

Sprite II is a direct solenoid operated spool valve, with a short stroke, and packless design, for 3 or 4 way applications. It may be continuously operated with or without line lubrication, and mounted in any position. It is a sub-base mounted valve, meaning the same valve may be mounted to either individual sub-bases, or mounted to a multi-station manifold, from 2 to 12 stations, with any combination of 3 or 4 way operations. All solenoids are rated for continuous duty.

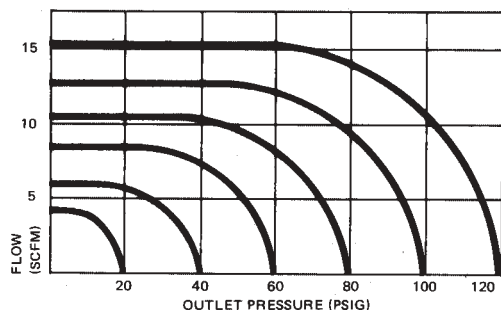

$C_v = 23$   
 $SCFM = 22.48 C_v \sqrt{\frac{(P_1 - P_2) P_2}{G \cdot T_1}}$   
 G = SPECIFIC GRAVITY (AIR G=1)  
 T<sub>1</sub> = ABS. TEMP. (460° F.)  
 P<sub>1</sub> = SUPPLY ABS. PRESS. (PSIG + 14.7)  
 P<sub>2</sub> = OUTLET ABS. PRESS. (PSIG + 14.7)

|                  |  |
|------------------|--|
| Pressure Rating: | 125 PSI                                      |
| *Response Time:  | 6.0 Milliseconds                             |
| CV Rating:       | 0.23   |
| Filtration:      | 10 micron filter recommended                 |
| Lubrication:     | Line lubrication optional, but not necessary |

\*AC Coils - DC Coils are somewhat slower, but response time may be improved by the use of a Controllable Overvoltage Supply.

### Solenoid Data

All solenoid coils are furnished with 24 inch leadwire connections. Coils are varnished in conformance with MIL-V-173.

All voltages shown at right are furnished at no extra cost. For other voltages, consult factory. AC coils may be used for either 50 cycle or 60 cycle service.

| Voltage        | Amperage (Milli-Amps) |       | Wattage |
|----------------|-----------------------|-------|---------|
|                | 12VDC                 | 24VDC |         |
| 6 VDC          | 460                   |       | 2.8     |
| 12VDC          | 230                   |       | 2.8     |
| 24VDC          | 115                   |       | 2.8     |
| 12VAC/50-60Hz  | 1,600                 | 800   | 5.2     |
| 24VAC/50-60Hz  | 800                   | 400   | 5.2     |
| 115VAC/50-60Hz | 160                   | 80    | 5.2     |
| 230VAC/50-60Hz | 80                    | 40    | 5.2     |

# SPRITE VALVES

## Single Sub-base Mounting

Between the valve and the sub-base is a locating pin which assures accurate alignment of valve and sub-base. Valves are secured with two mounting screws.

The mounting of this valve may be achieved by one of two methods:

1. Sub-base may be bulkhead mounted using 1/4-20 threaded mounting holes on the bottom of the sub-base.
2. The same holes are counter-bored from the top of the sub-base to accept #8 screws for surface mounting.

Valves and sub-bases may be ordered separately; however, factory assembly is available at a nominal charge.

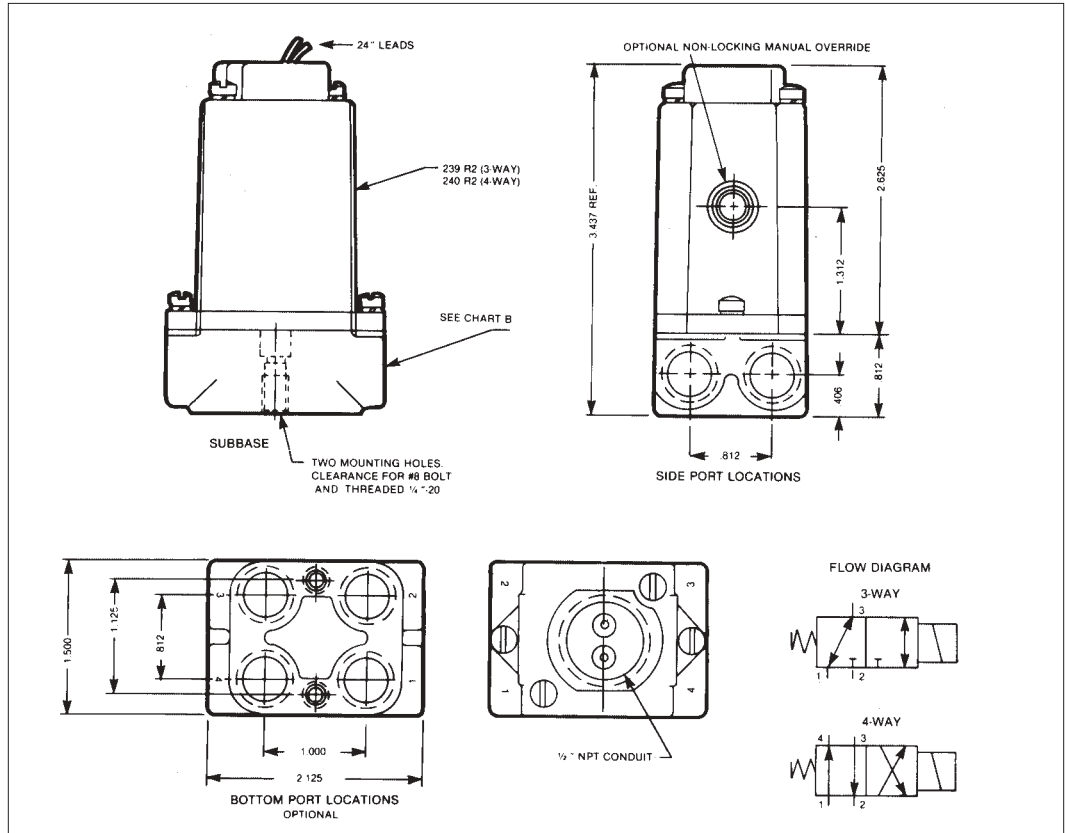

CHART A

| Operation             | Port Identification |          |               |               |
|-----------------------|---------------------|----------|---------------|---------------|
|                       | 1                   | 2        | 3             | 4             |
| 3-Way Normally Open   | Inlet               | Exhaust  | Cylinder      | -             |
| 3-Way Normally Closed | Exhaust             | Inlet    | Cylinder      | -             |
| 3-Way Diverter        | Cylinder            | Cylinder | Inlet         | -             |
| 4-Way Common Exhaust  | Inlet               | Exhaust  | N.C. Cylinder | N.O. Cylinder |

CHART B

| Sub Base Porting |       |                       |
|------------------|-------|-----------------------|
| Base Model #     |       | Description           |
| 3-Way            | 4-Way |                       |
| 231S             | 241S  | Side Ported, 1/8 NPT  |
| 232S             | 242S  | Side Ported 1/4 NPT   |
| 231B             | 241B  | Bottom Ported 1/8 NPT |
| 232B             | 242B  | Bottom Ported 1/4 NPT |



**ALKON**

# SPRITE VALVES

## Multiple Manifold Mounting

Sprite II is also available for use in compact, multi-function manifolds that offer the advantages of:

- Compact installation
- Fewer connections
- Faster installation

Additionally, it is one of the few valves available in the industry today that permits the combining of 4-way, 3-way, normally open and normally closed functions into a single manifold assembly.

Each manifold services up to twelve valves with only one common inlet and one common exhaust port. The common inlet and exhaust ports are 3/8 inch NPT, and cylinder ports are 1/4 inch NPT.

When used for manifold mounting, standard Sprite II valves are aligned directly to the manifold base with a positive locating pin, and connected with two mounting screws. Manifolds and valves are packaged separately unless specified. Factory assembly and pressure testing of manifold assemblies are available for nominal charge.

Open stations can be shut off with blanking kits.

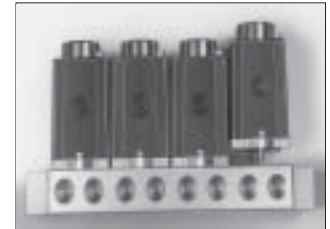

**Versatility** - manifolds any combination of 3-way or 4-way valves together

**Compactness** - combines 2 to 12 different valves into a compact, multi-function manifold

NOTE: Longer and special manifolds available - Consult Factory

**Mounting Ease** - uses only two easy-access bolts to mount individual valves to manifold

**Convenient Porting** - manifold services all valves with one common inlet and one common exhaust port - all cylinder ports located in the same plane for easy piping, neater installation

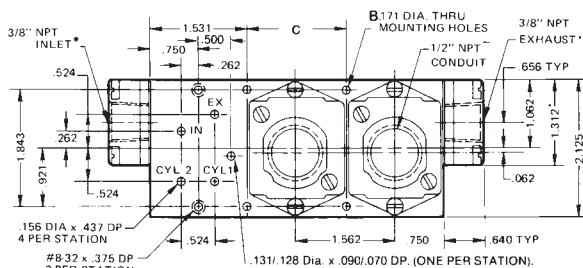

\* Inlet & exhaust may be interchanged

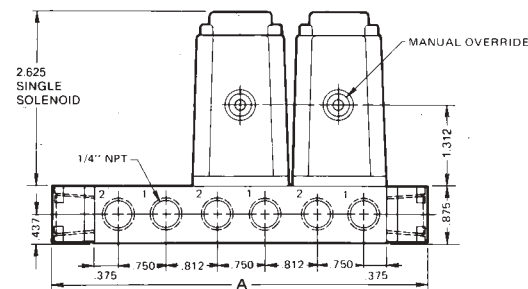

## Manifold Dimensions

| Manifold Model No. | No. Of Stations | A      | B | C      |
|--------------------|-----------------|--------|---|--------|
| 20806-2            | 2               | 4.344  | 2 | -      |
| 20806-3            | 3               | 5.906  | 4 | 1.562  |
| 20806-4            | 4               | 7.469  | 4 | 3.125  |
| 20806-5            | 5               | 9.031  | 4 | 4.688  |
| 20806-6            | 6               | 10.594 | 4 | 6.250  |
| 20806-7            | 7               | 12.156 | 4 | 7.813  |
| 20806-8            | 8               | 13.719 | 4 | 9.375  |
| 20806-9            | 9               | 15.281 | 4 | 10.937 |
| 20806-10           | 10              | 16.844 | 4 | 12.500 |
| 20806-11           | 11              | 18.406 | 4 | 14.063 |
| 20806-12           | 12              | 19.969 | 4 | 15.625 |

## Valve Port Designations

| Valve Model No. | Description                        | Port Designation |                |
|-----------------|------------------------------------|------------------|----------------|
|                 |                                    | 1                | 2              |
| 230-R2          | 3 Way N.C. Single Sol. Spring Ret. | Not Used         | Cyl. Port      |
| 239-R2          | 3 Way N.O. Single Sol. Spring Ret. | Cyl. Port        | Not Used       |
| 240-R2          | 4 Way Single Sol. Spring Ret.      | N.C. Cyl. Port   | N.O. Cyl. Port |

**Angle Flow Controls**

Angle Flow Control valves are designed to provide accurate flow control in a compact, labor saving package. Features like built in push-in fittings, pre-applied thread sealant, convenient swivel design and unique needle design all add up to a package that will save time, money and energy when accurate control is needed on pneumatic actuators.



**DESIGN FEATURES:**

- Choice of built in Series AQ push-in fittings or NPTF connections.
- Pre-applied Teflon based thread sealant.
- Recessed screw driver adjustment or optional knurled aluminum knob.
- Convenient swivel feature for ease of tubing alignment.
- 5 PSI cracking pressure.

**CONSTRUCTION:**

- Stem: Brass
- Body: Anodized Aluminum
- Fitting: Brass
- Needle: Stainless Steel
- Seals: Buna-N

**SPECIFICATIONS:**

- Maximum Operating Pressure: 150 PSI
- Temperature Range: -10°F to + 160°F
- Low 5 PSI cracking pressure
- Use with polyethylene, nylon, or copper tubing, also with polyurethane 90 durometer and over.

**OPTIONS:**

- Electroless Nickel Plated Stem
- Viton Seals
- BSPT & Metric "OD" Tube Connections
- Knurled Aluminum Knob with Locknut

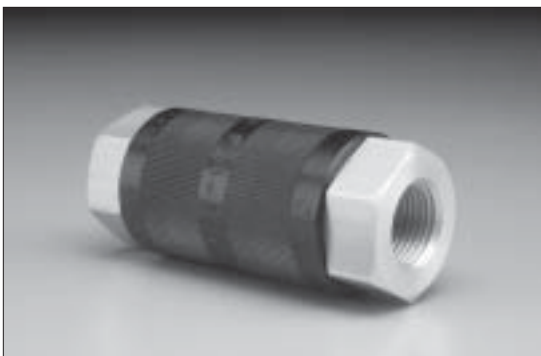

**Flo-Set Control Valves**

Flo-Set flow controls are an effective and accurate means of controlling the speed of pneumatic cylinders. They can easily be mounted inline anywhere in your system.

A controlled setting of the exhaust port of the cylinder allows a set back pressure to smoothly control piston velocity. They are recommended for all pneumatic applications to 150 PSI.

**DESIGN FEATURES:**

- Easily mounted for inline applications.
- Anodized aluminum for corrosion protection.
- Knurled sleeve for non-slip adjustment.
- Precision fit so vibration will not change adjusted setting.
- Excellent controlled flow and high free flow.
- For sizes 1/4, 3/8, 1/2 and 3/4 NPT.



**ALKON**

## FLOW CONTROLS

### In-Line Flow Controls, Needle & Check Valves

The Alkon Series J Flow Control, Needle and Check Valves offer substantially higher flow than any other comparable valve in their size or pressure range. Alkon pioneered the two taper needle and the in-line flow path designs to provide the highest flow coupled with the most sensitive metering from full open to full closed.

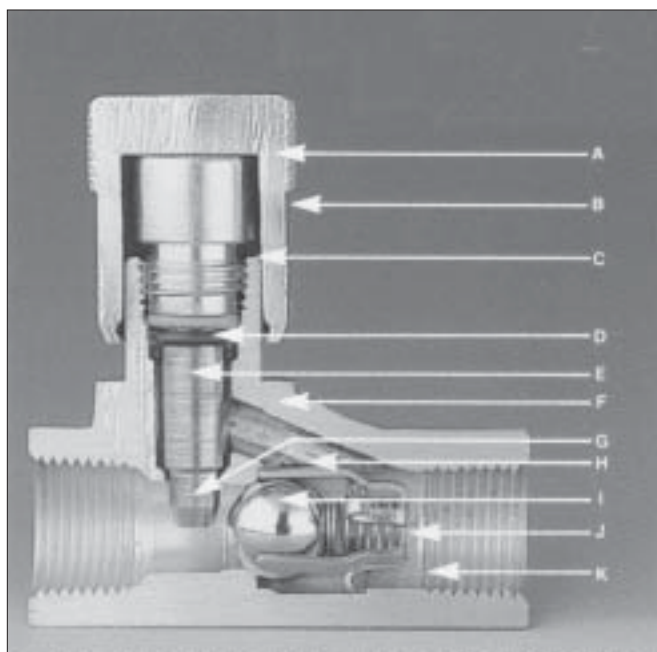

#### DESIGN FEATURES:

- A. Aluminum control knob permits adjustment of flow with valve under pressure.
- B. Locking set screw on control knob.
- C. Brass retainer acts as a positive stop for needle travel.
- D. Buna-N seal standard (Viton seal available) one-piece back-up ring to prevent extrusion.
- E. Heat treated, ground and polished 416 stainless steel needle.
- F. One-piece, high tensile brass forged body.
- G. Four stage needle provides the most sensitive flow metering from full closed to full open.
- H. Large unobstructed orifices.
- I. Stainless steel ball acts against a lapped seat to provide best sealing.
- J. The stainless steel cage acts as a spring support ball guide and ball stop. The spring is stainless steel wire.
- K. In-line check valve has an orifice larger than the nominal pipe size. Low pressure differential, no chatter and low friction loss.

#### FEATURES FOR DESIGN-IN QUALITY

- Positive no-leak stem seal
- Safe positive stop for needle travel
- Precision calibrated dial to determine and allow a return to required flow settings
- Maximum Operating Pressure: 3,000 PSI
- 2 PSI check cracking pressure
- One piece forged housing

#### OPTIONS

- Nickel plating for service with corrosive media
- Friction O-Ring for micrometer adjustment
- Viton seals
- British standard parallel pipe threads
- Removable knob



NOTE:

Patents 3,421,547 and 3,441,249



# FLOW CONTROLS

## Angle Flow Controls, In-Line Flow Controls, In-Line Needle & Check Valves, Flo-Set Flow Controls

### ANGLE FLOW CONTROL WITH SERIES AQ TUBE CONNECTION

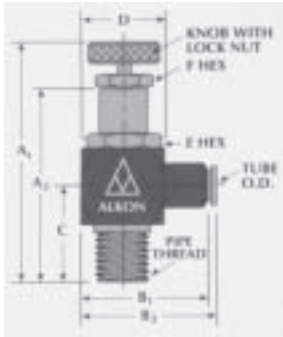

| PART NO.   | TUBE O.D. | PIPE THREAD | A <sub>1</sub> | A <sub>2</sub> | B <sub>1</sub> | B <sub>2</sub> | C    | D    | E    | F   |
|------------|-----------|-------------|----------------|----------------|----------------|----------------|------|------|------|-----|
| JAQ-5/32x2 | 5/32      | 1/8 NPT     | 1.70           | 2.48           | 1.28           | 1.41           | .75  | .63  | 9/16 | 1/2 |
| JAQ-4x2    | 1/4       | 1/8 NPT     | 1.70           | 2.48           | 1.41           | 1.55           | .75  | .63  | 9/16 | 1/2 |
| JAQ-4x4    | 1/4       | 1/4 NPT     | 1.81           | 2.61           | 1.38           | 1.52           | 1.06 | .75  | 5/8  | 1/2 |
| JAQ-6x4    | 3/8       | 1/4 NPT     | 1.81           | 2.61           | 1.38           | 1.70           | 1.06 | .75  | 5/8  | 1/2 |
| JAQ-6x6    | 3/8       | 3/8 NPT     | 2.19           | 2.83           | 1.56           | 2.07           | 1.16 | .88  | 7/8  | 1/2 |
| JAQ-8x8    | 1/2       | 1/2 NPT     | 2.83           | 3.72           | 1.88           | 2.07           | 1.44 | 1.13 | 1    | 1/2 |

### ANGLE FLOW CONTROL WITH FEMALE PIPE THREADS

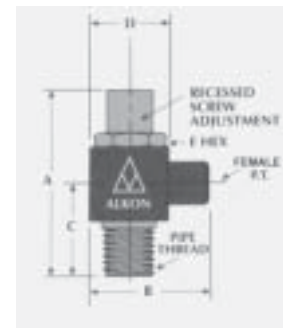

| PART NO. | FEMALE THREAD | MALE THREAD | A <sub>1</sub> | A <sub>2</sub> | B <sub>1</sub> | C    | D    | E    | F   |
|----------|---------------|-------------|----------------|----------------|----------------|------|------|------|-----|
| JPT-2x2  | 1/8 NPT       | 1/8 NPT     | 1.70           | 2.48           | 1.28           | .75  | .63  | 9/16 | 1/2 |
| JPT-2x4  | 1/8 NPT       | 1/4 NPT     | 1.81           | 2.61           | 1.18           | 1.06 | .75  | 5/8  | 1/2 |
| JPT-4x2  | 1/4 NPT       | 1/8 NPT     | 1.70           | 2.48           | 1.41           | .75  | .63  | 9/16 | 1/2 |
| JPT-4x4  | 1/4 NPT       | 1/4 NPT     | 1.81           | 2.61           | 1.38           | 1.06 | .75  | 5/8  | 1/2 |
| JPT-4x6  | 1/4 NPT       | 3/8 NPT     | 2.19           | 2.83           | 1.50           | 1.16 | .88  | 7/8  | 1/2 |
| JPT-6x4  | 3/8 NPT       | 1/4 NPT     | 1.81           | 2.61           | 1.39           | 1.06 | .75  | 5/8  | 1/2 |
| JPT-6x6  | 3/8 NPT       | 3/8 NPT     | 2.19           | 2.83           | 1.56           | 1.16 | .88  | 7/8  | 1/2 |
| JPT-6x8  | 3/8 NPT       | 1/2 NPT     | 2.83           | 3.72           | 1.75           | 1.44 | 1.13 | 1    | 1/2 |
| JPT-8x8  | 1/2 NPT       | 1/2 NPT     | 2.83           | 3.72           | 1.88           | 1.44 | 1.13 | 1    | 1/2 |

KNURLED ALUMINUM KNOB:

Add "K" after first three letters of part number "JAQK" or "JPTK"

### FLOW CONTROL VALVE

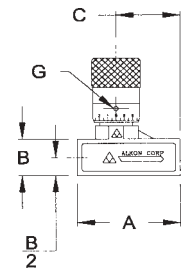

| MODEL NO.  |               | PIPE SIZE NPTF | VALVE DIMENSIONS, INCHES |       |       |       |      |       |            | C <sub>v</sub> FACTOR |                      | APPROX. WEIGHT |             |                  |
|------------|---------------|----------------|--------------------------|-------|-------|-------|------|-------|------------|-----------------------|----------------------|----------------|-------------|------------------|
| BRASS BODY | NICKEL PLATED |                | A                        | B     | C     | D     | E    | F     | G HEX SIZE | CHECK VALVE ORIFICE   | NEEDLE VALVE ORIFICE |                | CHECK VALVE | NEEDLE FULL OPEN |
| JF1        | JF1N          | 1/8            | 1.468                    | .562  | .913  | 1.803 | .250 | .687  | 3/32       | .206                  | .125                 | .60            | .30         | .19              |
| JF2        | JF2N          | 1/4            | 1.937                    | .687  | 1.232 | 2.000 | .250 | .687  | 3/32       | .281                  | .187                 | 1.30           | .60         | .28              |
| JF3        | JF3N          | 3/8            | 2.312                    | .875  | 1.545 | 2.531 | .300 | .937  | 3/32       | .421                  | .250                 | 2.85           | 1.08        | .54              |
| JF4        | JF4N          | 1/2            | 3.250                    | 1.187 | 2.117 | 3.218 | .375 | 1.250 | 3/32       | .515                  | .375                 | 4.96           | 1.75        | 1.75             |
| -          | JF6N          | 3/4            | 4.000                    | 1.750 | 2.625 | 3.906 | .375 | 1.250 | 3/32       | .718                  | .500                 | 9.00           | 3.20        | 2.32             |
| -          | JF8N          | 1              | 4.000                    | 1.750 | 2.625 | 3.906 | .375 | 1.250 | 3/32       | .718                  | .500                 | 9.20           | 3.20        | 2.20             |

### IN-LINE NEEDLE VALVE

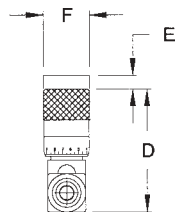

| MODEL NO.  |               | PIPE SIZE NPTF | VALVE DIMENSIONS, INCHES |       |       |       |      |       |            | C <sub>v</sub> FACTOR |                  |
|------------|---------------|----------------|--------------------------|-------|-------|-------|------|-------|------------|-----------------------|------------------|
| BRASS BODY | NICKEL PLATED |                | A                        | B     | C     | D     | E    | F     | G HEX SIZE | ORIFICE               | NEEDLE FULL OPEN |
| JN1        | JN1N          | 1/8            | 1.468                    | .562  | .913  | 1.803 | .250 | .687  | 3/32       | .125                  | .30              |
| JN2        | JN2N          | 1/4            | 1.937                    | .687  | 1.232 | 2.000 | .250 | .687  | 3/32       | .187                  | .60              |
| JN3        | JN3N          | 3/8            | 2.312                    | .875  | 1.545 | 2.531 | .300 | .937  | 3/32       | .250                  | 1.08             |
| JN4        | JN4N          | 1/2            | 3.250                    | 1.187 | 2.117 | 3.218 | .375 | 1.250 | 3/32       | .375                  | 1.75             |
| -          | JN6N          | 3/4            | 4.000                    | 1.750 | 2.625 | 3.906 | .375 | 1.250 | 3/32       | .500                  | 3.20             |
| -          | JN8N          | 1              | 4.000                    | 1.750 | 2.625 | 3.906 | .375 | 1.250 | 3/32       | .500                  | 3.20             |



# FLOW CONTROLS

# ALKON

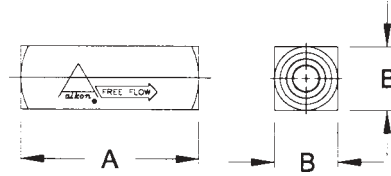

## IN-LINE CHECK VALVE

| MODEL NO.  |               |                |       |       |         |                       |
|------------|---------------|----------------|-------|-------|---------|-----------------------|
| BRASS BODY | NICKEL PLATED | PIPE SIZE NPFT | A     | B     | ORIFICE | C <sub>v</sub> FACTOR |
| JC1        | JC1N          | 1/8            | 1.468 | .562  | .206    | .64                   |
| JC2        | JC2N          | 1/4            | 1.937 | .687  | .281    | 1.35                  |
| JC3        | JC3N          | 3/8            | 2.312 | .875  | .421    | 3.22                  |
| JC4        | JC4N          | 1/2            | 3.250 | 1.187 | .515    | 4.96                  |
| -          | JC6N          | 3/4            | 4.000 | 1.750 | .718    | 9.00                  |
| -          | JC8N          | 1              | 4.000 | 1.750 | .718    | 9.20                  |

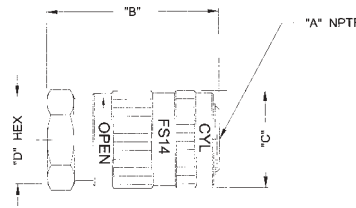

## FLO-SET FLOW CONTROL VALVE

| MODEL NUMBER | A NPT | B INCHES | MM    | C INCHES | MM   | D INCHES | MM   |
|--------------|-------|----------|-------|----------|------|----------|------|
| FS14         | 1/4   | 2        | 50.8  | 1-1/16   | 27.0 | 1        | 25.4 |
| FS38         | 3/8   | 2-29/32  | 73.8  | 1-3/8    | 34.9 | 1-1/16   | 27.0 |
| FS12         | 1/2   | 3-13/32  | 86.5  | 1-11/32  | 42.9 | 1-3/8    | 34.9 |
| FS34         | 3/4   | 4-9/32   | 108.7 | 2-1/8    | 28.6 | 1-3/4    | 44.5 |

| MODEL NUMBER   | NPT SIZE | CONTROLLED FLOW 0 TO MAX. SCFM | FREE FLOW CONTROL ADJ. MAX. SCFM | C <sub>v</sub> | SCHEDULE 40 PIPE SCFM | AIR PRESS. PSI |
|----------------|----------|--------------------------------|----------------------------------|----------------|-----------------------|----------------|
| 1/4 x 2 Nipple |          |                                |                                  |                |                       |                |
| FS14           | 1/4      | 30                             | 43                               | 1.1            | 81                    | 40             |
|                |          | 39                             | 62                               |                | 114                   | 60             |
|                |          | 54                             | 79                               |                | 174                   | 80             |
| 3/8 x 4 Nipple |          |                                |                                  |                |                       |                |
| FS38           | 3/8      | 71                             | 79                               | 2.8            | 140                   | 40             |
|                |          | 100                            | 114                              |                | 194                   | 60             |
|                |          | 130                            | 149                              |                | 247                   | 80             |
| 1/2 x 5 Nipple |          |                                |                                  |                |                       |                |
| FS12           | 1/2      | 140                            | 147                              | 5.2            | 214                   | 40             |
|                |          | 194                            | 206                              |                | 302                   | 60             |
|                |          | 247                            | 259                              |                | 390                   | 80             |
| 3/4 x 6 Nipple |          |                                |                                  |                |                       |                |
| FS34           | 3/4      | 242                            | 285                              | 9.2            | 371                   | 40             |
|                |          | 340                            | 395                              |                | 517                   | 60             |
|                |          | 432                            | 523                              |                | 697                   | 80             |

The standard cubic feet per minute (SCFM) that the flow control valves will pass exhaust to atmosphere is compared on the chart to the SCFM of air that will flow through a similar size and length of standard schedule 40 pipe.



## OMNI SERIES VALVES

- OMNI 150
- OMNI 250
- OMNI 375
- OMNI 500

Today's industrial fluid power operations demand faster, more reliable power and control air valve systems. Alkon's Omni Series valves meet these needs...

**A Broad Range of Applications** makes the Omni Series best suited for the widest variety of applications - automation and machine tool control, packaging machinery, robotics clamping, fixtures, cylinder controls, and most other pneumatic devices.

**Reaction Time** is fast and reliable, and will speed your production capability. For example, it takes less than 16 milliseconds to shift the valve spool.

**Superior Performance** is guaranteed. Omni Series valves are the fastest, lightest, most compact high-flowing valve packages in the industry. On the basis of performance, Omni valves deliver more production per dollar spent.

**Flexibility** is an outstanding feature of all Omni Series valves. Air pilot or solenoid operated, base or manifold mounted, horizontal or vertical stacking or in-line mounting, Omni Series valves can be configured to your specific production or maintenance requirements.

**Stacking Feature** is another Omni Series advantage. Omni series valves can be assembled into a variety of stacking arrangements to reduce piping requirements and increase mounting options. These stacks offer high-flow performance in compact, space saving packages. Stacking models have been designed to reduce downtime and quick and easy valve add-ons, removals or other changes.

Omni Series valves are specifically engineered to withstand harsh factory environments. Omni valves are precision-machined, lightweight, compact and corrosion resistant. They're simple and easy to maintain, designed for reliable performance and minimum downtime.

### PATENTED "THIN LIP" SEAL & SPOOL FEATURES:

- Teflon loaded seals provide millions of trouble-free cycles
- Unique wiping action eliminates contaminant build-up in bore
- Reduces spool hang-up due to compressor or oil varnishing

### DESIGN FEATURES:

- Patented Teflon loaded Viton "Thin Lip Seal"
- Minimum breakout friction
- Anodized extruded aluminum
- Compact size
- 2 and 3 position, 3 and 4 way
- Highest flow in industry
- Many standard body styles
- 50 standard primary operators
- Proven performer in both lubricated and dry systems
- Adaptable for vacuum and low pressures
- Operates on standard filtration
- Variety of mounting options
- Simple to maintain

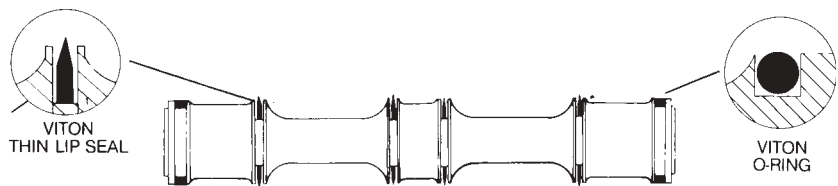

### HOW IT WORKS (refer to spool illustration below)

- "Relaxed" no pressure on either side of seal.
- Pressure from right moves seal to left, expanding it against bore to sealed position.
- Force applied to left shifts spool... nominal sealing friction causes lip to flex like diaphragm. Flexing action reduces breakout friction. This spool can react quickly with very low force requirement.

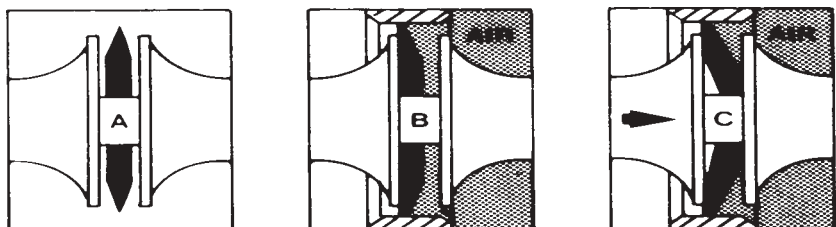



# OMNI SERIES VALVES

# ALKON

ENGINEERING DATA FOR ALL OMNI VALVES

## AVAILABILITY

|            | 2-Way      | 3-Way      | 4-Way | Inline | Stacking | Common Wire Way | Base Mounting | Elect. Timers | Explos. Proof |
|------------|------------|------------|-------|--------|----------|-----------------|---------------|---------------|---------------|
| <b>150</b> | Plug 3-Way | •          | •     | •      | •        |                 |               |               |               |
| <b>250</b> | Plug 3-Way | •          | •     | •      | •        | •               | •             | •             | •             |
| <b>375</b> | Plug 3-Way | •          | •     | •      | •        | •               | •             | •             | •             |
| <b>500</b> | Plug 4-Way | Plug 4-Way | •     | •      | •        | •               |               | •             | •             |

## OPERATORS

| <b>150</b> | • | • | • | • |   |   | • |   |
|------------|---|---|---|---|---|---|---|---|
| <b>250</b> | • | • | • | • | • |   |   | • |
| <b>375</b> | • | • | • | • | • | • | • | • |
| <b>500</b> | • |   | • |   |   |   |   |   |

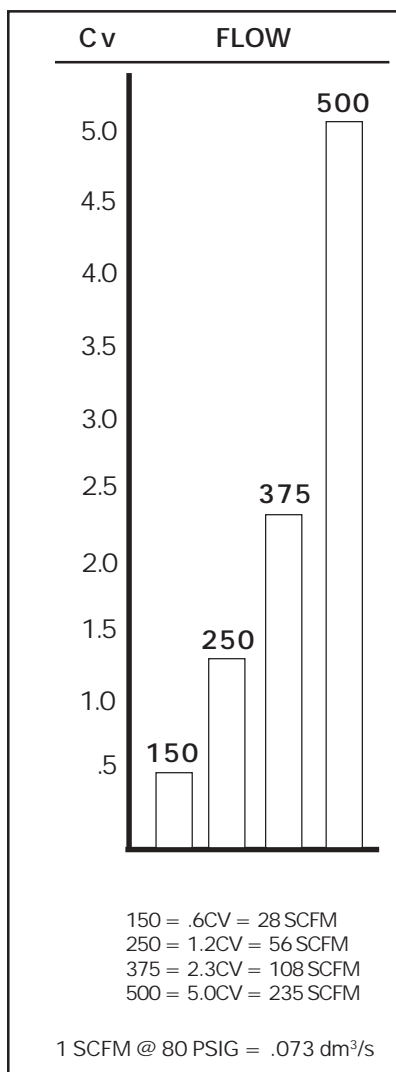

## OPERATOR REPLACEMENT

- For air piloted valves, manual valves, and mechanically operated valves, furnish valve series and operator number only.
- For solenoid operators, specify voltage as well.

EXAMPLE: 375-37 120/60



# OMNI SERIES VALVES

## ENGINEERING DATA FOR ALL OMNI VALVES

### ENGINEERING DATA

|                                       | OMNI 150             | OMNI 250             | OMNI 375             | OMNI 500             |
|---------------------------------------|----------------------|----------------------|----------------------|----------------------|
| Media                                 | Air and inert gasses | Air and inert gasses | Air and inert gasses | Air and inert gasses |
| Maximum Operating Pressure            | 150 PSI              | 150 PSI              | 150 PSI              | 150 PSI              |
| Min. Pilot Pressure Solenoid/Solenoid | 20 PSI               | 15 PSI               | 15 PSI               | 15 PSI               |
| Min. Pilot Pressure Solenoid/Spring   | 45 PSI               | 40 PSI               | 45 PSI               | 45 PSI               |
| Min. Pilot Pressure Air/Spring        | 45 PSI               | 40 PSI               | 40 PSI               | 30 PSI               |
| Min. Pilot Pressure Air/Air           | 20 PSI               | 15 PSI               | 15 PSI               | 15 PSI               |
| Vacuum To Below Min. Pilot            | Available            | Available            | Available            | Available            |
| Flow Rate @ 80 PSI (SCFM)             | 28                   | 56                   | 108                  | 235                  |
| Max. Temperature                      | 185°F                | 185°F                | 185°F                | 185°F                |
| For Other Temps.                      | Consult Factory      | Consult Factory      | Consult Factory      | Consult Factory      |

Pre-lubricated at factory to operate on lubricated or non-lubricated systems.

### SOLENOID SPECIFICATIONS

|                   | OMNI 150       |         | OMNI 250        |                 | OMNI 375        |                 | OMNI 500        |                 |
|-------------------|----------------|---------|-----------------|-----------------|-----------------|-----------------|-----------------|-----------------|
|                   | Current (Amps) |         | Current (Amps)  |                 | Current (Amps)  |                 | Current (Amps)  |                 |
| Standard Voltages | In Rush        | Holding | In Rush         | Holding         | In Rush         | Holding         | In Rush         | Holding         |
| 110/50Hz          | .09            | .04     | .13             | .08             | .13             | .08             | .13             | .08             |
| 120/60Hz          | .07            | .03     | .11             | .07             | .13             | .08             | .13             | .08             |
| 215/50Hz          |                |         | .06             | .04             | .13             | .08             | .13             | .08             |
| 240/60Hz          |                |         | .06             | .03             | .13             | .08             | .13             | .08             |
| 24/60Hz           |                |         | .6              | .3              | .13             | .08             | .13             | .08             |
| 12VDC             | .24            | .24     | .6<br>DIN= .87  | .6<br>DIN= .87  | .6<br>DIN= .87  | .6<br>DIN= .87  | .6<br>DIN= .87  | .6<br>DIN= .87  |
| 24/VDC            | .12            | .12     | .29<br>DIN= .43 | .29<br>DIN= .43 | .29<br>DIN= .43 | .29<br>DIN= .43 | .29<br>DIN= .43 | .29<br>DIN= .43 |
| 120VDC            |                |         | .05             | .05             | .13             | .08             | .13             | .08             |

- Other AC and DC Voltages Available Upon Request
- Explosion Proof Solenoids Available on Some Models
- All Solenoids Designed to Meet or Exceed U.L. & CSA Requirements



## OMNI SERIES VALVES

### ENGINEERING DATA FOR ALL OMNI VALVES

#### SOLENOID HOUSING CLASSIFICATION

##### CONDUIT AND GROMMET HOUSINGS WITH MOLDED COILS MEET:

- NEMA 1      General Purpose = Indoors
  - NEMA 2      Dripproof = Indoors
  - NEMA 3      Driptight = Indoors
  - NEMA 4\*     Watertight & Dusttight = Indoors & Outdoors
  - NEMA 6\*     Submersible, Watertight, Dusttight & Sleet-Ice Resistant = Indoors & Outdoors
- \* Specify "Potted Coil Option to meet NEMA 4 & 6.

##### EXPLOSION PROOF HOUSINGS MEET:

- NEMA 7C, 7D & CSA      Class I = Groups C & D = Explosion Proof
- NEMA 8C, 8D & CSA      Class I = Groups C & D = Explosion Proof
- NEMA 9E, 9F, 9G & CSA    Class II = Groups E, F & G = Explosion Proof

##### J.I.C. HOUSINGS MEET:\*

- NEMA 3R     Rainproof & Sleet = (Ice) Resistant = Outdoors
- NEMA 3S     Dusttight, Raintight, Sheet & Ice Proof = Outdoors
- NEMA 4       Watertight & Dusttight = Indoors & Outdoors
- NEMA 4X     Watertight, Dusttight & Corrosion Resistant = Indoors & Outdoors
- NEMA 6       Submersible, Watertight & Dusttight = Indoors  
Sleet-Ice Resistant = Indoors & Outdoors
- NEMA 12     Industrial Use = Dusttight & Driptight = Indoors
- NEMA 13     Oiltight & Dusttight = Indoors

\* DIN operators meet IP • 65, for NEMA ratings please consult factory.

#### LUBRICATION

All Alkon packed spool valves are pre-lubricated and will operate dry (with no additional lubrication), however a lubricated system will greatly extend the service life of any valve. Optional lubricants for special services are available.

The following oils are popular, easily obtainable fluids that are recommended for use with Alkon packed spool valves: Gulf Harmony 47, Mobil DTE Medium, Shell Tellus 29, Texaco Rondo B, Sohivis 47, Molubaloy, and Sunnis 921. Many other fluids are acceptable lubricants providing they do not contain detergents that will attack Buna N or Viton seals.

#### HOW THE SLEEVE AND PLUNGER SOLENOID AIR PILOT ASSEMBLY WORKS

The diagram at right shows how this assembly works. Pilot air for the solenoid pilot is supplied from main line air through internal valve passage "A". With the solenoid in the de-energized position, the spring-loaded plunger seals against the air inlet "B". When the solenoid is energized, the plunger moves back and its top seat seals against the exhaust outlet "E". The top seat of the plunger is spring compensated against wear to assure complete, lifetime sealing. When the plunger moves off inlet port "B" the pilot air passes through outlet "C" to act on the end of the spool "D" causing the spool to shift. When the solenoid is de-energized, the plunger returns back to its starting position, the pilot air exhausts out of the spool chamber through inlet "C", past the plunger and out through outlet "E" to atmosphere.

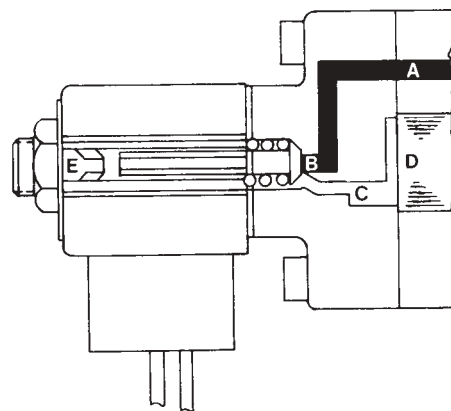



# OMNI SERIES VALVES

ENGINEERING DATA FOR ALL OMNI VALVES

## REPLACEMENT PARTS

| SPOOL REPLACEMENT |                        |                        |                 |   |                                     |                 |   |                                     |  |                                     |
|-------------------|------------------------|------------------------|-----------------|---|-------------------------------------|-----------------|---|-------------------------------------|--|-------------------------------------|
|                   | OMNI 150               |                        | OMNI 250        |   |                                     | OMNI 375        |   |                                     | OMNI 500   |                                     |
| Operator #        | 3 Way<br>2 Pos.        | 4 Way<br>2 Pos.        | 3 Way<br>2 Pos. | 4 Way<br>2 Pos.                             | 4 Way<br>3 Pos.                     | 3 Way<br>2 Pos. | 4 Way<br>2 Pos.                             | 4 Way<br>3 Pos                      | 4 Way<br>2 Pos.                                    | 4 Way<br>3 Pos.                     |
| 06<br>08<br>43    | N/A<br>N/A<br>90A20321 | N/A<br>N/A<br>90A20322 | N/A             | N/A   | N/A                                 | 90A20095        | 90A20106                                    | N/A                                 | N/A  | N/A                                 |
| 09                | N/A                    | N/A                    | 90A20349        | 90A20227                                    | N/A                                 | 90A20078        | 90A20075                                    | N/A                                 | N/A  | N/A                                 |
| 10                | N/A                    | 90A20304               | 90A20356        | 90A20228                                    | N/A                                 | 90A20078        | 90A20075                                    | N/A                                 | N/A  | N/A                                 |
| 15, 19            | N/A                    | N/A                    | N/A             | 90A20229                                    | B90A20233<br>P90A20234<br>E90A20235 | 90A20112        | 90A20113                                    | N/A                                 | N/A  | N/A                                 |
| 15T, 19T          | N/A                    | N/A                    | N/A             | N/A   | N/A                                 | N/A             | N/A   | B90A20185<br>P90A20186<br>E90A20187 | N/A  | N/A                                 |
| 27, 30<br>31, 32  | N/A                    | N/A                    | N/A             | N/A   | N/A                                 | 90A20201        | 90A20127                                    | N/A                                 | N/A  | N/A                                 |
| ALL OTHERS        | 90A20290               | 90A20289               | 90A20325        | 90A20225<br>ALUMINUM<br>90A20226<br>PLASTIC | B90A20230<br>P90A20231<br>E90A20232 | 90A20078        | 90A20075<br>ALUMINUM<br>90A20132<br>PLASTIC | B90A20175<br>E90A20176<br>P90A20177 | 90A20301<br>DOUBLE OPER<br>90A20300<br>SINGLE OPER | B90A20297<br>P90A20298<br>E90A20299 |
| 34, 39            | N/A                    | N/A                    | N/A             | N/A   | N/A                                 | 90A20116        | 90A20117                                    | N/A                                 | N/A  | N/A                                 |

| COIL/SOLENOID REPLACEMENT |   |          |          |          |          |          |          |          |
|---------------------------|---|----------|----------|----------|----------|----------|----------|----------|
|                           | OMNI 150  |          | OMNI 250 |          | OMNI 375 |          | OMNI 500 |          |
| Operator #                | COIL  | SOL      | COIL     | SOL      | COIL     | SOL      | COIL     | SOL      |
| 37 = 68<br>AC/DC          | 26A01056 110/50<br>26A01057 24VDC<br>26A01058 12VDC | 09A01064 |          |          |          |          |          |          |
| 33 = 67<br>AC/DC          | 26A01056 110/50<br>26A01057 24VDC<br>26A01058 12VDC | 09A01065 |          |          |          |          |          |          |
| 60 <u>AC</u><br>DC        | 26A01072<br>SPECIFY VOLTAGE                         | 09A01065 |          |          |          |          |          |          |
| 61 <u>AC</u><br>DC        | 26A01072<br>SPECIFY VOLTAGE                         | 09A01064 |          |          |          |          |          |          |
| 33-37-38<br>64-65         |   |          | 26A01017 | 09A01001 | 26A01017 | 09A01001 | 26A01017 | 09A01001 |
| 42-66                     |   |          | 26A01043 | 09A01039 | 26A01043 | 09A01039 | 26A01043 | 09A01039 |
| 60-61<br>62-63            |   |          | 26A01033 | 09A01023 | 26A01033 | 09A01023 | 26A01033 | 09A01023 |
| 67-68<br>82-86            |   |          | 26A01039 | 09A01038 | 26A01039 | 09A01038 | 26A01039 | 09A01038 |



# OMNI 150 SERIES VALVES Flow Rating: .6 CV (2.04 dm<sup>3</sup>/s)

# ALKON

## ORDERING INFORMATION

**E - 150 - 02 - - 011 - 37 - L - 1**

### VOLTAGES

1. 120/60 AC\*
2. 12 VDC\*
3. 24/60 AC\*
4. 240/60 AC\*
5. 24 VDC\*

\* Denotes standard voltages - others on request

### OPERATOR SUFFIX - OPTIONAL

OPERATOR "A" (see listing)

### BODIES

| First Digit<br>Center Position | Second Digit<br>Port Size | Third Digit<br>Body Style/Type            |
|--------------------------------|---------------------------|---|
| 0 = None                       | 1 = 1/8 NPT               | 1 = Inline, 4-Way                         |
|                                | 3 = 10-32/M5              | 2 = Stacking, 4-Way<br>Individual Exhaust |
|                                |                           | 3 = Stacking, 4-Way                       |
|                                |                           | 5 = Stacking, 3-Way                       |
|                                |                           | 7 = Inline, 3-Way                         |

NOTE: Inline 3-Way bodies are field convertible to normally open or normally closed.

### OPERATOR SUFFIX - OPTIONAL

OPERATOR "B" (See Listing)

SERIES (150)

Use when ordering metric ports only

## Ordering Procedure for OMNI 150 Series

1. Code: E - Use when ordering metric ports only
2. Series: Identifies valve series
3. Operator: B - secondary - returns spool  
Operator suffix if applicable
4. Body: The body style selects type of mounting and port sizes
5. Operator: A - primary operator  
Operator suffix if applicable
6. Volts: Specify dash number

## Valve Stack

### Ordering Procedure

All 150 Series valve stacks are assembled with tie rods at the factory at no additional charge.

To order, first list the model and quantity of each valve required. Second, specify the size of end plate assembly required (1/8 or 1/4 ports).

Consult the factory for other options.

\*NOTE: When using 33 or 37 operators in stacks, one spacer #150-1109 between each valve is required.

### OPERATOR SUFFIX - OPTIONAL

| Letter Code | Description       | Availability                |
|-------------|-------------------|-----------------------------|
| E           | External Air      | For unassigned operator #'s |
| G           | Green Palm Button | 10, 43                      |
| L           | Lighted Connector | 33, 37, 67, 68              |
| R           | Red, HD Spring    | 02, 04                      |
| R           | Red Palm Button   | 10, 43                      |
| Y           | .8 Watt Sol., DIN | 67, 68 (DC Only)            |

### OPERATOR

- 01 Blank End Cap (no spring)
- 02 Spring Return
- 03 Air Pilot
- 04 Air Pilot - Spring Offset
- 10 Palm button panel mount spring return
- 27 Plunger operator
- 33\* Solenoid with DIN connector & 1/2" conduit port
- 37\* Solenoid with DIN connector 1/2" conduit connector and manual override
- 43 Panel mount palm button push pull to operate detented (must be used with 01 operator)
- 60 Solenoid with lead wires
- 61 Solenoid with lead wires and manual override
- 67 Solenoid with DIN connector
- 68 Solenoid with DIN connector and manual override



# OMNI 150 SERIES VALVES

## 4-Way/Air Pilot



| Operator         | Pipe Size | Model#        | Schematic |
|------------------|-----------|---------------|-----------|
| Air Pilot        | M5        | 150-02-031-03 |           |
| Spring Return    | 1/8       | 150-02-011-03 |           |
| Double Air Pilot | M5        | 150-03-031-03 |           |
| Pilot            | 1/8       | 150-03-011-03 |           |

## 4-Way/Solenoid



| Operator                             | Pipe Size | Model#        | Schematic |
|--------------------------------------|-----------|---------------|-----------|
| Double Solenoid with Manual Override | M5        | 150-68-031-68 |           |
| Override                             | 1/8       | 150-68-011-68 |           |

## 3-Way/Palm Button



| Operator      | Pipe Size | Model#        | Schematic |
|---------------|-----------|---------------|-----------|
| Palm Button   | M5        | 150-02-037-10 |           |
| Spring Return | 1/8       | 150-02-017-10 |           |

## Operators

**02-Operator Spring Return End Cap**  
(01-Operator dimensions are the same as 02)

**03-Operator Air Pilot End Cap**

**Lead Wire Coil**  
60 Operator — Solenoid  
61 Operator — Solenoid with Manual Override

**33 Operator — 1/2 Conduit**  
**37 Operator — 1/2 Conduit With Manual Override**

**PLUNGER**  
27 Operator

**Manual Override**

**DIN Connector**  
67 Operator — Solenoid  
68 Operator — Solenoid With Manual Override

**INLIE BODY**

**Note:** 3-Way Inline bodies are field convertible NC or NO.

**Note:** 5/32" noneffective travel at end of movement. 7# force required to operate.

**DOUBLE AIR PILOT**

**SINGLE AIR PILOT**

**1/8 PILOT PORT**

**03**

**68**



# ALKON

## OMNI 150 SERIES VALVES

### New "Flip-Out" Design

The Alkon "Flip-Out" design is a special OMNI valve feature which makes valve changes, add-ons or removals quick and easy. Notched valve bodies and end plates permit "Flip-Out" valve replacement or stack rearrangement in seconds. Simply loosen top tie-rod, remove, and lift out valve.



#### 015 STACKING BODY LESS OPERATORS

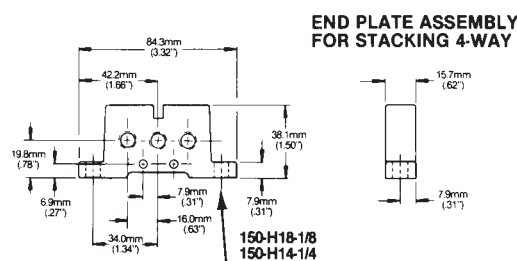
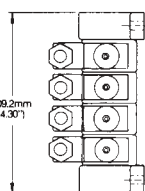
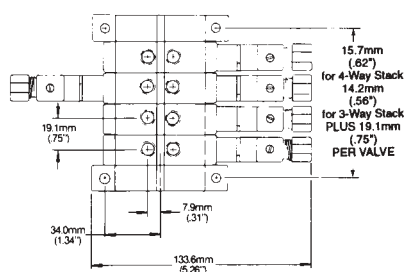
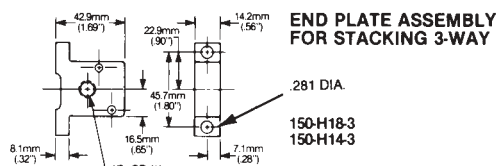
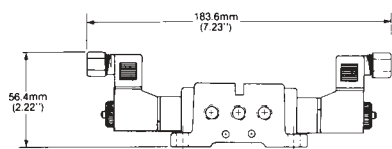
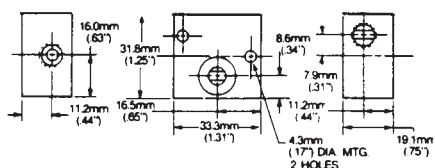

.281 DIA.

#### END PLATE ASSEMBLY FOR STACKING

|           |     |            |
|-----------|-----|------------|
| 150-V14   | 1/4 | Vertical   |
| 150-H14-3 | 1/4 | Horizontal |
| 150-H14   | 1/4 | Horizontal |
| 150-V18   | 1/8 | Vertical   |
| 150-H18-3 | 1/8 | Horizontal |
| 150-H18   | 1/8 | Horizontal |

#### VERTICAL MOUNT TOP PLATE

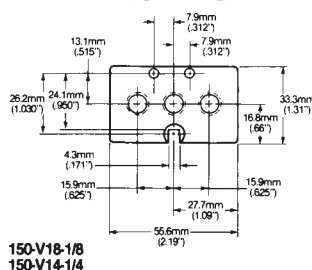

#### VERTICAL MOUNT BASE

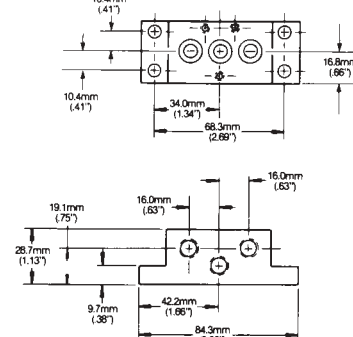

**Note:** End Plate Ass'y Furnished with 2 End Plates, 3 Tie Rods, All Nuts & O' Rings Required.



# OMNI 250 SERIES VALVES Flow Rating: 1.2 CV (4.09 dm<sup>3</sup>/s)

## ORDERING INFORMATION

**E - 250 - 02 - - 011 - 37 - E - 1**

### VOLTAGES

1. 120/60 AC\*
2. 12 VDC\*
3. 24/60 AC\*
4. 240/60 AC\*
5. 24 VDC\*

\* Denotes standard voltages - others on request.

### OPERATOR SUFFIX - OPTIONAL

OPERATOR "A" (see listing)

### BODIES

| First Digit<br>Center Position | Second Digit<br>Port Size | Third Digit<br>Body Style/Type                 |
|--------------------------------|---------------------------|--|
| 0 = None                       | 0 = 1/4 NPT               | 0 = Body Blank, 4-Way                          |
| B = Blocked                    | 1 = 1/8 NPT               | 1 = Inline, 4-Way                              |
| E = Exhausted                  | 2 = 1/8 BSPP              | 2 = Stacking, 4-Way<br>Ind'l exhaust           |
| P = Pressurized                | 5 = 1/4 BSPP              | 3 = Stacking, 4-Way                            |
|                                |                           | 4 = Base mounted                               |
|                                |                           | 7 = Inline, 3-Way                              |
|                                |                           | 9 = Stacking, 4-Way<br>Common wireway<br>mount |

### OPERATOR SUFFIX - OPTIONAL

OPERATOR "B" (See Listing)

SERIES (250)

Use when ordering metric ports only

### Ordering Procedure for OMNI 250 Series

1. Code: E - Use when ordering metric ports only
2. Series: Identifies valve series
3. Operator: B - secondary - returns spool  
Operator suffix if applicable
4. Body: The body style selects type of mounting & port sizes
5. Operator: A - primary operator  
Operator suffix if applicable
6. Volts: Specify dash number
7. For stacking valves refer to page 36 & 37

**Note:** Air pilot or solenoid operators may be used with either 2 position or 3 position body styles

### OPERATOR

- 01 Blank End Cap
- 02 Spring Return
- 03 Air Pilot
- 04 Air Pilot - Spring Offset
- 09 Palm button, push to operate
- 10 Palm button panel mount spring return
- 13 Lever, parallel, push to operate
- 15 Lever, parallel, detented, push-pull to operate  
(must be used with 01 operator)
- 33 Solenoid with 1/2" conduit connection
- 37 Solenoid with 1/2" conduit connection & manual override
- 38 Solenoid with 1/2" conduit connection & locking manual  
override
- 42 Solenoid - explosion proof
- 50 Solenoid Micro timer - On delay, lighted, manual  
override (see catalog for ranges - add suffix)

### OPERATOR SUFFIX - OPTIONAL

| Letter | Code | Description                                       | Availability                |
|--------|------|---|-----------------------------|
| E      |      | External Air                                      | For unassigned operator #'s |
| F      |      | Filtered & Potted Solenoid<br>for NEMA 4 Solenoid | 33, 37, 38, 64, 65          |
| G      |      | Green Palm Button                                 | 09, 10                      |
| H      |      | Class H Coil, Viton<br>Sleeve & Plunger           | 33, 37, 38, 64, 65          |
| L      |      | Lighted Connector                                 | 67, 68, 82, 86              |
| R      |      | Red, HD Spring                                    | 02, 04                      |
| R      |      | Red Palm Button                                   | 09, 10                      |
| V      |      | Hi-Temp (Viton)<br>Sleeve & Plunger Only          | 33, 37, 38, 64, 65          |
| Y      |      | .8 Watt Sol., DIN                                 | 67, 68 (DC Only)            |

- 51 Solenoid Micro timer - Off delay, lighted, manual  
override (see catalog for ranges - add suffix)
- 52 Solenoid Micro timer - Interval, lighted, manual  
override (see catalog for ranges - add suffix)
- 53 Solenoid Micro timer - Cycle, lighted, manual  
override (see catalog for ranges - add suffix)
- 59 Solenoid with lead wires & locking manual override
- 60 Solenoid grommet coil with lead wires
- 61 Solenoid grommet coil with lead wires, manual override
- 64 Solenoid with 1/2" conduit connection & external pilot supply
- 65 Solenoid with 1/2" conduit connection, manual override,  
external pilot supply
- 67 Solenoid with DIN connector
- 68 Solenoid with DIN connector & manual override
- 82 Solenoid with DIN connector, locking manual override
- 83 Air pilot with manual override
- 86 Solenoid with DIN connector, manual override,  
external pilot supply



## OMNI 250 SERIES VALVES

### Air Pilot Operated

The OMNI Series 3-Way and 4-Way valves can be air pilot operated with three types of assembly.

1. **DOUBLE AIR PILOT (NO VALVE SPOOL SPRING)** The valve spool is shifted by a momentary air pilot signal to either of the "A" or "B" Pilots.
2. **SINGLE AIR PILOT, SPRING RETURN** The valve spool is maintained in the normal rest position in the "B" end. A maintained air pressure signal at the "A" end greater than the spring force will shift the valve spool.
3. **DOUBLE AIR PILOT, SPRING OFFSET** The valve spool is maintained in the normal rest position in the "B" end. A maintained air pressure signal at the "A" end greater than the spring force will shift the valve spool, providing no air pressure signal is on the "B" end. By controlling the pressure differential between "A" and "B" a variety of applications are available.



#### Basic Valve Model Numbers

|                                | Pipe Size | Number        | Schematics |  |  |
|--------------------------------|-----------|---------------|------------|--|--|
| Air Pilot spring return        | 1/8 NPTF  | 250-02-011-03 |            |  |  |
|                                | 1/4 NPTF  | 250-02-001-03 |            |  |  |
| Double air pilot               | 1/8 NPTF  | 250-03-011-03 |            |  |  |
|                                | 1/4 NPTF  | 250-03-001-03 |            |  |  |
| Double air pilot spring offset | 1/8 NPTF  | 250-04-011-03 |            |  |  |
|                                | 1/4 NPTF  | 250-04-001-03 |            |  |  |

### Double Air Pilot

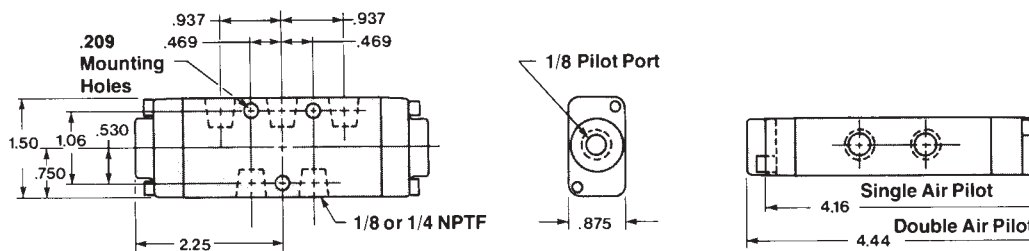

Note: For 3-Way body see page 45

### 03 Air Pilot

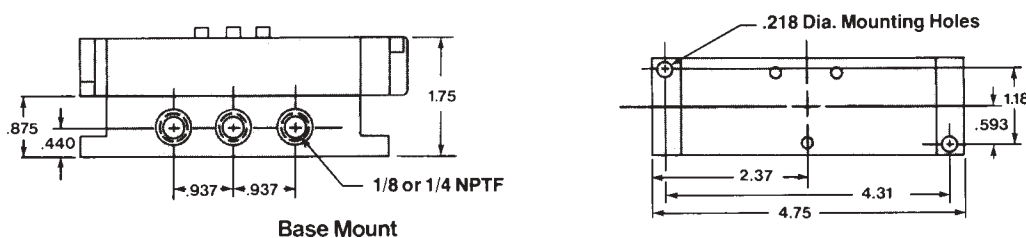

Note: Bases ordered separately



# OMNI 250 SERIES VALVES

## Solenoid Air Pilot Operated



The OMNI 250 3-Way and 4-Way Solenoid Air Pilot Operated Valves Offer These Special Electrical Features:

- Solenoid assembly so reliable it's guaranteed.
- A variety of standard AC or DC voltage options.
- Plug-in electrical connectors.
- Explosion proof operators.
- All coils molded epoxy.
- Low watt coils available.
- Built to meet or exceed UL standards.
- CSA approved.
- Intrinsically safe operators available.
- Class H, hi-temp solenoids available.

### 4-WAY VALVE

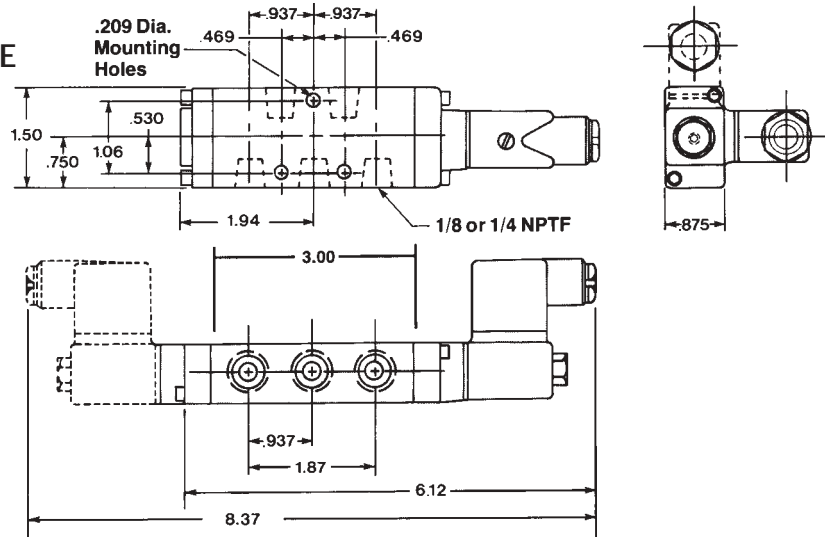

### 3-WAY VALVE BODY

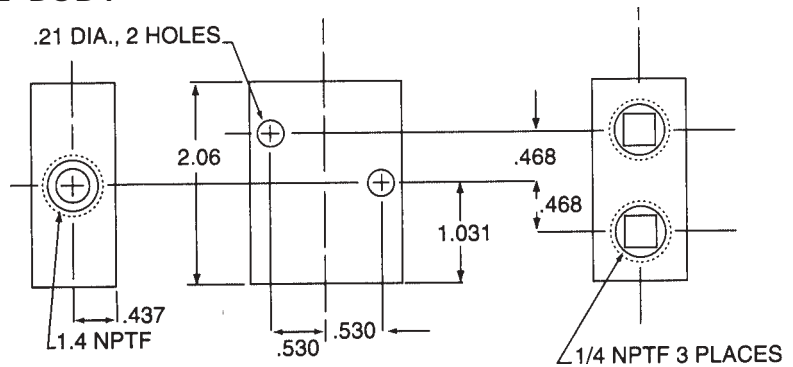

### 4-WAY VALVE BASE MOUNT

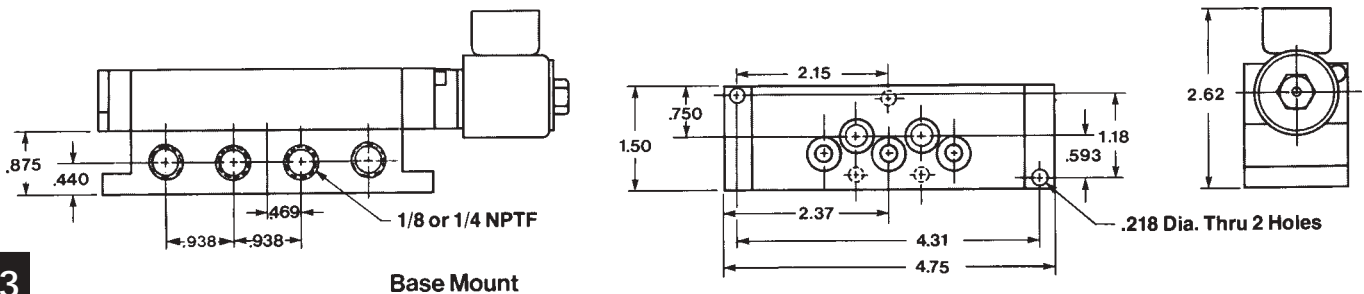



## OMNI 250 SERIES VALVES

### Solenoid Air Pilot Operated

- Single solenoid spring return with micro timer
- Single solenoid spring return with manual override, explosion proof.
- Double solenoid momentary contact
- Double solenoid momentary contact and manual override

#### Basic Valve Model Numbers

| Pipe Size | Number        | Schematics |
|-----------|---------------|------------|
| 1/8 NPTF  | 250-02-011-50 |            |
| 1/4 NPTF  | 250-02-001-50 |            |
| 1/8 NPTF  | 250-02-011-42 |            |
| 1/4 NPTF  | 250-02-001-42 |            |
| 1/8 NPTF  | 250-33-011-33 |            |
| 1/4 NPTF  | 250-33-001-33 |            |
| 1/8 NPTF  | 250-37-011-37 |            |
| 1/4 NPTF  | 250-37-001-37 |            |

Standard solenoid operators  
available voltages - 6VDC, 12VDC, 24VDC, 120/60  
240/60, 24/60

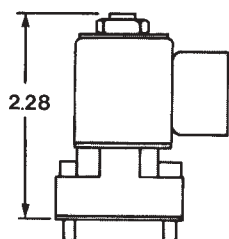

Conduit Connection

- 33 Solenoid
- 37 Solenoid w/ Non-Locking Manual Override
- 38 Solenoid With Locking Manual Override
- 64 Solenoid With External Supply
- 65 Solenoid With Manual Override External Supply

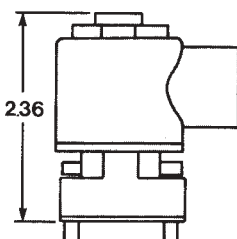

Explosion Proof

- 41 Explosion Proof Solenoid w/ Locking Override
- 42 Explosion Proof Solenoid With Manual Override

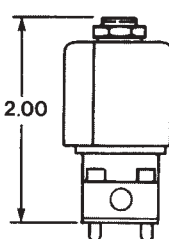

Lead Wire Connection

- 60 Solenoid with Lead Wires
- 61 Solenoid With Lead Wires And Manual Override

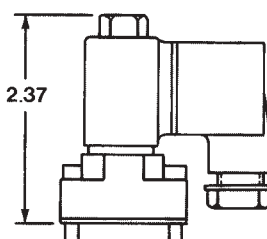

Din Connector

- 67 Solenoid
- 68 Solenoid With Manual Override
- 82 Solenoid With Locking Manual Override

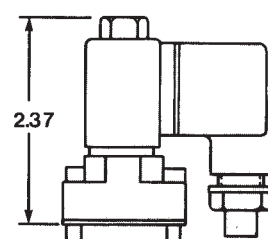

Common Wireway

- 67C Solenoid
- 68C Solenoid With Manual Override
- 82C Solenoid With Locking Manual Override

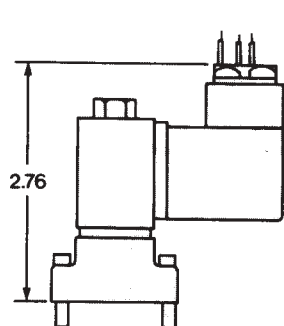

- 50 Micro timer-on delay w/ manual o'ride & light
- 51 Micro timer-off delay w/ manual o'ride & light

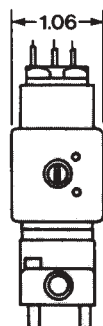

- 52 Micro timer-interval w/ manual o'ride & light
- 53 Micro timer-cycle w/ manual o'ride & light

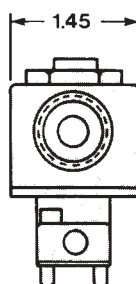

- 42 Non-Locking Override Push Type - Shown With Explosion Proof



- Locking Override Push and Turn Shown With Din Connector



- External Pilot Supplied With Barbed Fitting. Shown With Conduit Housing

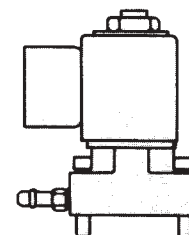

Note: 55 in...lbs. nut torque

### Manually Operated



Many valve applications require hand actuation. The OMNI 250 Series 4-way offers a rugged compact versatile answer. They can be mounted in any position or through a panel or can be actuated with buttons or levers.

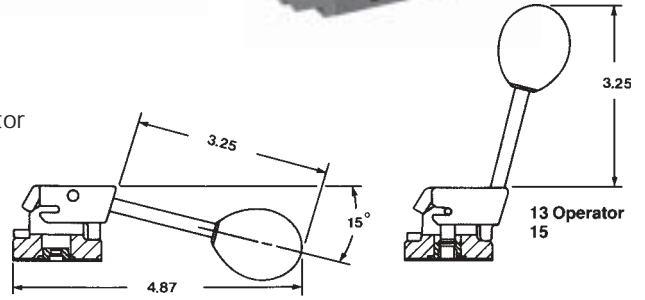

13 Operator  
15  
15T

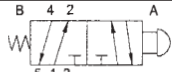
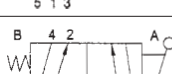
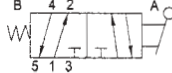

#### Basic Valve Model Number

|                                 | Pipe Size | Number        | Schematics  |
|---------------------------------|-----------|---------------|---|
| Palm button<br>spring return    | 1/8 NPTF  | 250-02-011-09 |    |
|                                 | 1/4 NPTF  | 250-02-001-09 |   |
| Parallel lever<br>spring return | 1/8 NPTF  | 250-02-011-13 |   |
|                                 | 1/4 NPTF  | 250-02-001-13 |  |

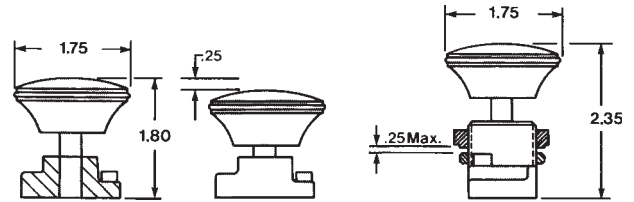

09 Operator

10 Operator

13 Operator  
15  
15T

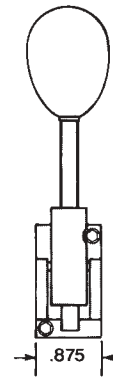
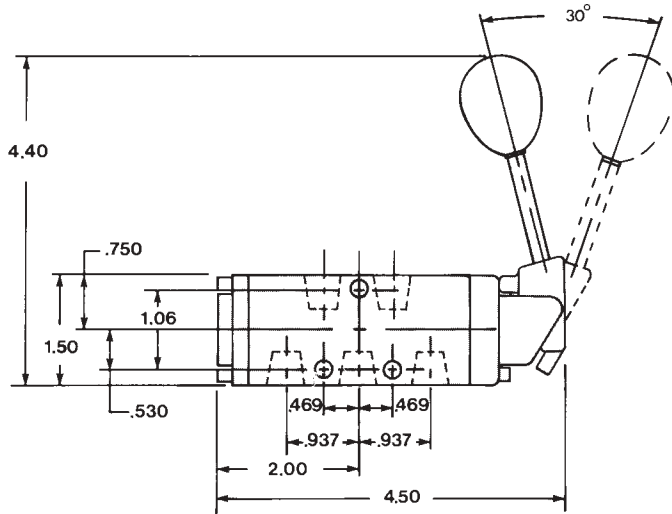

09 Operator  
10

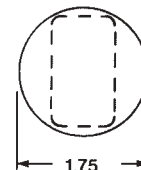
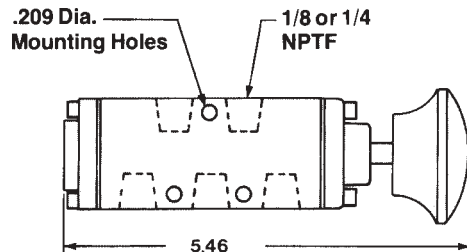



## OMNI 250 SERIES VALVES

### Stacking and Common Wireway Arrangements

The OMNI 250 Series valves can be assembled into a variety of stacking arrangements which greatly reduce piping requirements and increase mounting options. These stacks offer high flow performance in compact, space saving packages which include:

- 4-way, 5 ported stacks with common input and dual common exhaust or individual exhaust.
- Available tapped 1/8 or 1/4 NPTF.
- Horizontal or vertical mounting.
- Available with common electrical wireway.
- 2 and 3 position.
- Dual pressure available via blocking disc #32A01010.
- Common External Pilot Available.

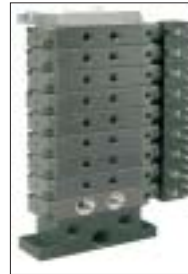

### Ordering Information:

All 250 Series valve stacks are assembled with tie rods at the factory at no additional charge. To order, First, list the quantity and model of each type of valve required, (see page 31). Second, determine the number of 3/8" wide spacers required between each valve. When 03, 04, 60Y, 61Y, 62Y, 63Y, 67, 68 and 82 operators are used, spacers are not required. When 09, 13, 15, 15T, 33, 37, 38 and 50, 51, 52, 53, 60, 61, 64 and 65 operators are used, allow one spacer between each valve, but not between a valve and end plate. For 42 operators, use two spacers between each valve but not between a valve and end plate. For common electrical wireway, spacers are not required. Third, specify the type of end plate assembly required (horizontal or vertical mounting and 1/8 or 1/4 NPTF ports). Fourth, for common wireway stack, specify model enclosure. (see below)



Spacer Plate  
(250-1054)

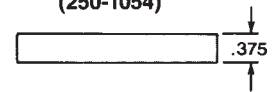

### Example

- (2) 250 Series stack each consisting of:
  - (4) 250-02-013-37 120/60 valve
  - (3) 250-1054 spacer plate
  - (1) 250-1333 horizontal end plate assy. 1/8 NPTF

### Example

- (2) 250 Series stack each consisting of:
  - (4) 250-02-019-68C 120/60 valve
  - (1) 250-1334 spacer plate assy.
  - (1) 25-1131 single solenoid enclosure

### Order Numbers for Common Wireway NEMA 4 Enclosure

| Description                         | Model   |
|-------------------------------------|---------|
| *2 thru 4 single solenoid enclosure | 25-1131 |
| *2 thru 4 double solenoid enclosure | 25-1132 |
| 5 thru 6 single solenoid enclosure  | 25-1133 |
| 5 thru 6 double solenoid enclosure  | 25-1134 |
| 7 thru 10 single solenoid enclosure | 25-1135 |
| 7 thru 10 double solenoid enclosure | 25-1136 |
| 11 + valves, consult factory        |         |

\*When ordering a 2 valve stack, one extra spacer must be ordered - #45A01058  
If any one valve in stack is double solenoid, you must order double solenoid enclosure.



### Order Numbers for Common Wireway and Standard Stack End Plate Assemblies

| Description   | Model    |
|---|----------|
| Vertical mount assembly (1/4 NPTF ports)                | 250-1334 |
| Horizontal mount assembly (1/4 NPTF ports)              | 250-1333 |
| Spacer Plate  | 250-1054 |
| Horizontal mount assembly (1/8 NPTF ports)              | 250-1334 |
| Vertical mount assembly (3/8 NPTF supply - 1/4 exhaust) | 250-1345 |

### Stacking Arrangements

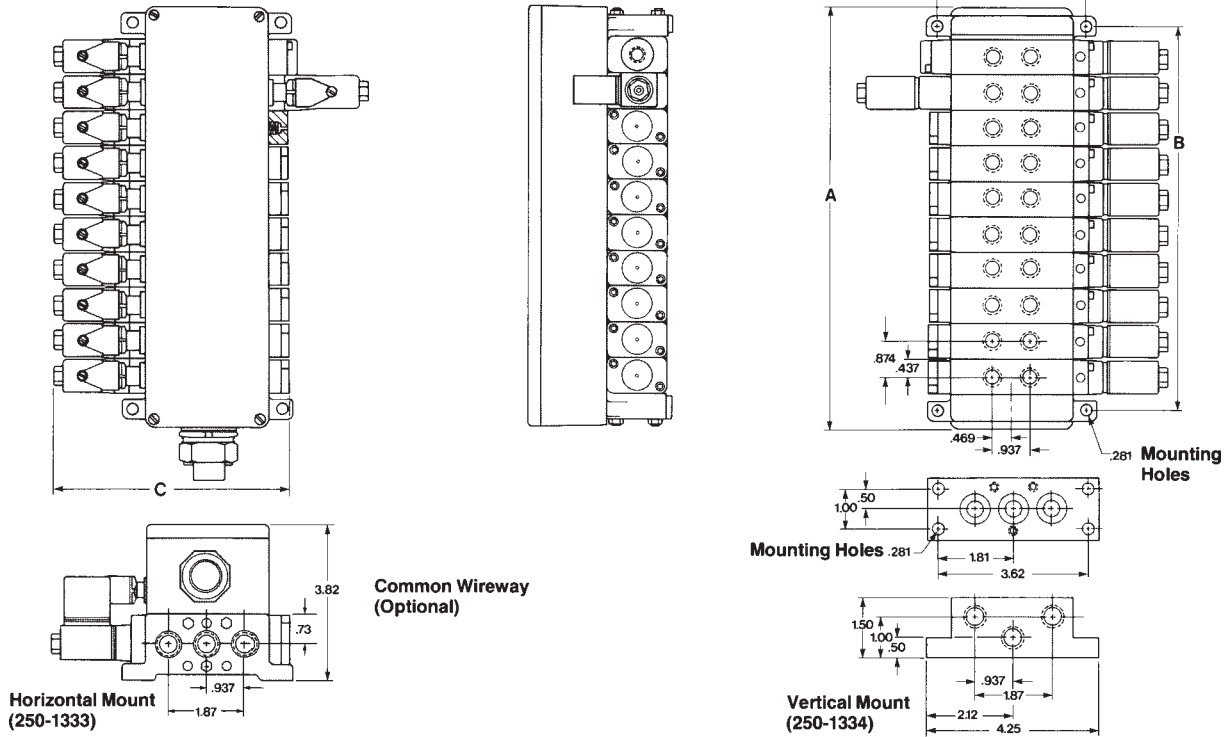

| No. Valves | A    | B    | Valve Style            | C    |
|------------|------|------|------------------------|------|
| 2 or 3     | 5.00 | 3.38 | 2 Pos. Single Solenoid | 5.86 |
| 4          | 5.00 | 4.25 | Spring Return          |      |
| 5          | 7.00 | 5.13 | 2 Pos. Single Solenoid | 6.07 |
| 6          | 7.00 | 6.00 | Air Return             |      |
| 7          | 9.80 | 6.88 | 2 Pos. Double          | 7.70 |
| 8          | 9.80 | 7.75 | Solenoid               |      |
| 9          | 9.80 | 8.63 |                        |      |
| 10         | 9.80 | 9.50 |                        |      |

**Note:**

Horizontal end plates may be attached with either the mounting feet on the port side or the side opposite. Unless otherwise specified, all common wireway stacks have the mounting feet on the port side and all other stacks have the feet on the side opposite the ports. When ordering, if more than one model number valve is to be stacked, specify valve position by numbering valves from left to right while facing the "B end" operators. If a vertical mounting plate is used, number valves starting from vertical plate.

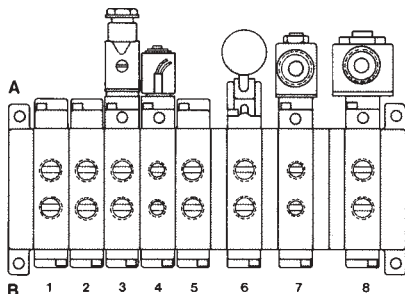

**Example:**

- 250 Stack Consisting of:
- (2) 250-02-003-03 air pilot
  - (1) 250-02-003-68 DIN connector
  - (1) 250-02-013-60Y Grommet
  - (1) 250-02-003-03 air pilot
  - (1) 250-01-003-15 lever
  - (1) 250-02-013-37 conduit
  - (1) 250-02-003-42 ex. proof
  - (4) 250-1054 spacer plate
  - (1) 250-1333 end plate ass'y.



## OMNI 250 SERIES VALVES

### Replacement Parts

#### Spool Replacement



3 Position "B"  
90A20230



3 Position "P"  
90A20231



3 Position "E"  
90A20232



3 Position "B" Lever  
90A20233



3 Position "P" Lever  
90A20234



3 Position "E" Lever  
90A20235



2 Position Palm Button  
90A20227



2 Position Panel  
MTD. Palm Button  
90A20228



2 Position Lever  
90A20229



2 Position  
90A20225 - Aluminum Spool - Mechanical Operators  
90A20226 - Plastic Spool - Solenoid and Air Operators

#### Coil Replacement

| Description  | Model    |
|--|----------|
| Coil with conduit housing, 7 watt,<br>33, 37, 38, 64, 65 operators   | 26A01017 |
| Coil or Grommet Connection, 7 watt,<br>59, 60, 61 operators          | 26A01033 |
| Coil with DIN connector, 8.5 watt,<br>67, 68, 82, 67C, 82C operators | 26A01039 |
| Coil with explosion proof housing, 7 watt,<br>42, 66 operators       | 26A01043 |

When ordering coil, give part number and voltage. Standard voltages are: 120/60, 240/60, 6VDC, 24VDC. For other voltages, consult factory.

Torque Settings for Coil Hold Down Nuts are:  
20-25 in-lbs. for Canned type operators  
20-25 in-lbs. for DIN operators  
55 in-lbs. for operators 42



# OMNI 375 SERIES VALVES Flow Rating: 2.3 CV (7.88 dm<sup>3</sup>/s)

## ORDERING INFORMATION

**E - 375 - 02 - - 011 - 67 - L - 1**

### VOLTAGES

1. 120/60 AC\*
2. 12 VDC\*
3. 24/60 AC\*
4. 240/60 AC\*
5. 24 VDC\*

\* Denotes standard voltages - others on request.

### OPERATOR SUFFIX - OPTIONAL

OPERATOR "A" (see listing)

### BODIES

#### First Digit

#### Center Position

- O = None
- B = Blocked
- E = Exhausted
- P = Pressurized

#### Second Digit

#### Port Size

- O = 1/4 NPT
- 5 = 1/4 BSPP
- 8 = 3/8 NPT
- 9 = 3/8 BSPP

#### Third Digit

#### Body Style/Type

- O = Body Blank, 4-Way
- 1 = Inline, 4-Way
- 2 = Stacking, 4-Way  
Ind'l exhaust
- 3 = Stacking, 4-Way
- 4 = Base mounted
- 7 = Inline, 3-Way
- 9 = Stacking, 4-Way  
Common wireway  
mount
- N = Namur mount

### OPERATOR SUFFIX - OPTIONAL

OPERATOR "B" (See Listing)

SERIES (375)

Use when ordering metric ports only

### Ordering Procedure for OMNI 375 Series

1. Code: E - Use when ordering metric ports only
2. Series: Identifies valve series
3. Operator: B - secondary - returns spool  
Operator suffix if applicable
4. Body: The OMNI 375 is a 2 or 3 position valve  
The body style selects type of mounting & port sizes  
(see page 48 for 3 position valves)
5. Operator: A - primary operator  
Operator suffix if applicable
6. Specify voltages or any other special conditions
7. For stacking valves, refer to pages 49 & 50
8. For manifold valves, refer to pages 51 & 52

### OPERATOR SUFFIX - OPTIONAL

| Letter Code | Description                               | Availability                |
|-------------|---|-----------------------------|
| E           | External Air                              | For unassigned operator #'s |
| F           | Filtered & Potted Solenoid                |                             |
|             | for NEMA 4 Solenoid                       | 33, 37, 38, 64, 65          |
| G           | Green Palm Button                         | 9 thru 12, 13, 43           |
| H           | Class H Coil, Viton                       |                             |
|             | Sleeve & Plunger                          | 33, 37, 38, 64, 65          |
| L           | Lighted Connector                         | 67, 68, 82, 86              |
| R           | Red, HD Spring                            | 02, 04                      |
| R           | Red Palm Button                           | 9 thru 12, 14, 43           |
| U           | Low Pilot Pressure Adaptor (U-Cup Piston) |                             |
| W           | 2.5 Watt DIN Solenoid                     | 67, 68, 82                  |
| Y           | .9 or .8 Watt Sol., DIN                   | 67, 68, 82 (DC Only)        |

# OMNI 375 SERIES VALVES

---



## OPERATOR NUMBER

- 01 Blank end cap
- 02 Spring Return
- 03 Air Pilot
- 04 Air Pilot - Spring offset
- 05 7/8" diameter knob push to operate
- 06 7/8" diameter knob detented, (must be used with 01 operator)
- 07 7/8" diameter knob, panel mounted, push to operate
- 08 7/8" diameter knob, panel mounted, detented, (must be used with 01 or 03 operator)
- 09 Palm button, push to operate
- 10 Panel Mount Palm button spring return
- 11 Palm button with guard, push to operate
- 12 Palm button, panel mounted, push to operate
- 13 Lever, parallel, push to operate
- 14 Palm button, detented, push-pull to operate (must be used with 01 operator)
- 15 Lever, parallel, detented, push-pull to operate (must be used with 01 operator)
- 17 Lever, perpendicular, push to operate (must be used with 02 operator)
- 19 Lever, perpendicular, detented, push-pull to operate (must be used with 01 operator)
- 27 Plunger operator
- 30 Roller lever, actuation left (reference supply port-right) (use with 02 operator)
- 31 Roller lever, actuation right (reference supply port-right) (use with 02 operator)
- 32 Roller lever, 2-way actuation (use with 02 operator)
- 33 Solenoid with 1/2" conduit ports
- 34 Foot pedal (must use with 02R operator)
- 37 Solenoid with 1/2" conduit connection and manual override
- 38 Solenoid with 1/2" conduit connection and locking manual override
- 39 Foot treadle, detented (must be used with 01 operator)
- 42 Solenoid - explosion proof, conduit connection, manual override
- 43 Panel mount palm button, push-pull to operate detented (must be used with 01 operator)
- 44 Rotary knob select, detented (must be used with 02 operator)
- 45 Key select, detented, (must be used with 02 operator)
- 50 Solenoid Micro timer - On delay, lighted, manual override (see catalog for ranges - add suffix)
- 51 Solenoid Micro timer - Off delay, lighted, manual override (see catalog for ranges - add suffix)
- 52 Solenoid Micro timer - Interval, lighted, manual override (see catalog for ranges - add suffix)
- 53 Solenoid Micro timer - Cycle, lighted, manual override (see catalog for ranges - add suffix)
- 54 Solenoid with 3 pin brad-harrison connector
- 55 Solenoid with 3 pin brad-harrison connector, manual override
- 59 Solenoid with lead wires and locking manual override
- 60 Solenoid grommet coil with lead wires
- 61 Solenoid grommet coil with lead wires, manual override
- 62 Solenoid grommet coil with lead wires and external pilot supply
- 63 Solenoid grommet coil with lead wires, manual override, external pilot supply
- 64 Solenoid with 1/2" conduit connection and external pilot supply
- 65 Solenoid with 1/2" conduit connection, manual override, external pilot supply
- 66 Solenoid - Explosion proof, 1/2" conduit connection, manual override, external pilot supply
- 67 Solenoid with DIN connector
- 68 Solenoid with DIN connector and manual override
- 69 Air pilot with 3 supply ports
- 70 Air pilot with shuttle - auxiliary port plugged
- 71 Air pilot with spring offset - 3 pilot supply ports
- 72 Air pilot with shuttle and spring offset - auxiliary outlet plugged
- 81 Air pilot with spool position indicator, manual override
- 82 Solenoid with DIN connector, locking manual override
- 83 Air pilot, manual actuator
- 86 Solenoid with DIN connector, manual override, external pilot supply

## OMNI 375 SERIES VALVES

### 3-WAY & 4-WAY SOLENOID AIR PILOT OPERATED



The OMNI 375 3-Way and 4-Way Solenoid Air Pilot Operated Valves Offer These Special Electronic Features:

- Solenoid assembly so reliable it's guaranteed.
- A variety of of standard AC or DC voltage options.
- Dual rated solenoids for 50/60 cycles.
- Plug in electrical connectors.
- Explosion proof operators.
- Low watt coils available (.9 watt).
- All coils molded epoxy - standard.
- J.I.C. housing available.
- Built to meet or exceed UL standards.
- C.S.A. approved.
- Electronic Micro-Timer for logic sequencing.
- Intrinsically safe solenoid available.
- Class H, hi-temp solenoid available.

#### 3-Way

#### 33 Operator

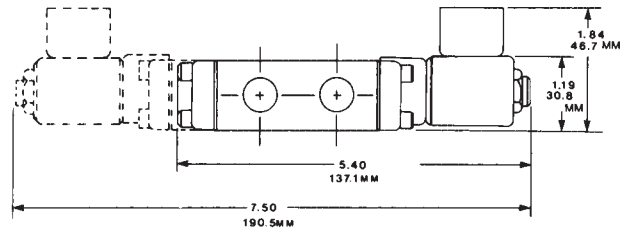
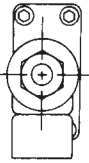
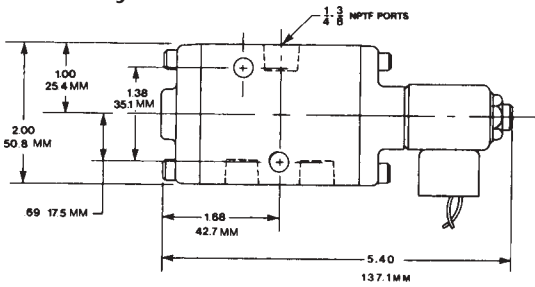

#### 4-Way

#### 33 Operator

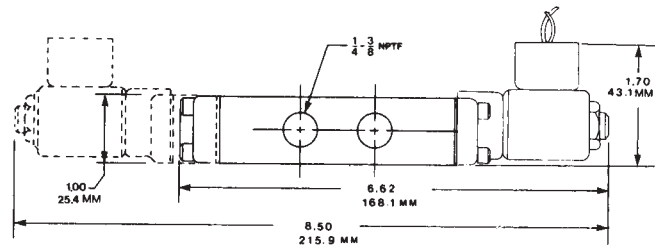
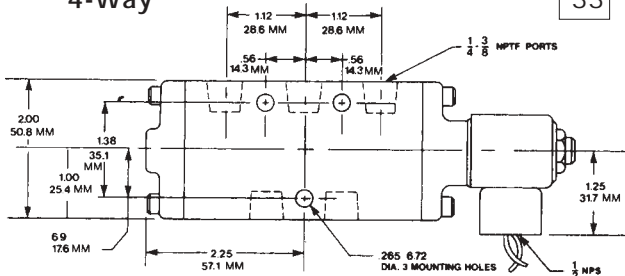

#### Base Mount

#### 33 Operator

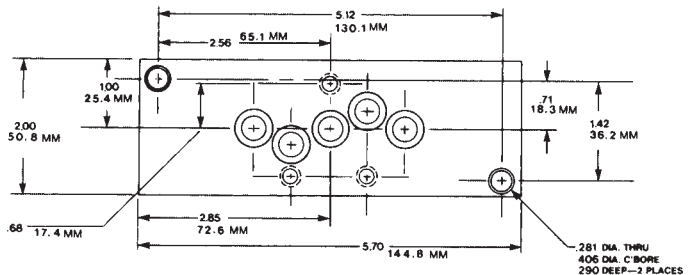
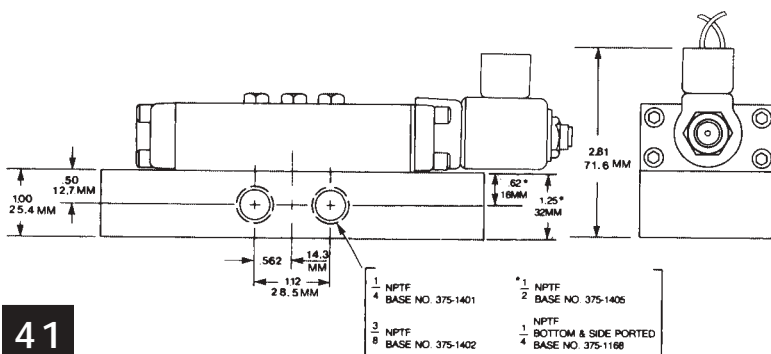



## OMNI 375 SERIES VALVES

### Basic Valve Model Numbers

| DESCRIPTION  | 3-Way     |               |            | 4-Way     |               |            |
|--|-----------|---------------|------------|-----------|---------------|------------|
|  | PIPE SIZE | NUMBER        | SCHEMATICS | PIPE SIZE | NUMBER        | SCHEMATICS |
| Double Solenoid Momentary Contact with Manual Override | 1/4 NPTF  | 375-37-007-37 |            | 1/4 NPTF  | 375-37-001-37 |            |
|  | 3/8 NPTF  | 375-37-087-37 |            | 3/8 NPTF  | 375-37-081-37 |            |
| Single Solenoid Spring Return with Manual Override     | 1/4 NPTF  | 375-02-007-37 |            | 1/4 NPTF  | 375-02-001-37 |            |
|  | 3/8 NPTF  | 375-02-087-37 |            | 3/8 NPTF  | 375-02-081-37 |            |

### Optional Solenoid Operators

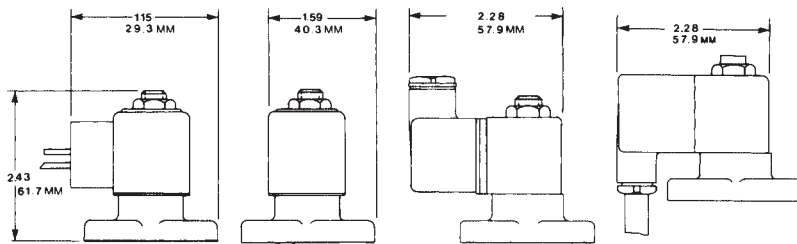

This Series of 4-way valves is available with base mounting which permits the removal or changing of a valve without disturbing the piping. The 375 Series valve is machined from extruded aluminum and available with 5 threaded ports in 1/4, 3/8 or 1/2 NPTF. The valve body (004) has 5 unthreaded ports on the wide part of the valve which mate with the five ports on the top of the base. The body is supplied with five Viton o-rings and is assembled to the base.

- 33 SOLENOID AIR PILOT CONDUIT CONNECTION
- 37 SOLENOID AIR PILOT WITH MANUAL OVERRIDE AND CONDUIT CONNECTION
- 38 SOLENOID AIR PILOT WITH LOCKING MANUAL OVERRIDE
- 64 SOLENOID EXTERNAL AIR PILOT WITH CONDUIT CONNECTION
- 65 SOLENOID EXTERNAL AIR PILOT WITH CONDUIT CONNECTION AND MANUAL OVERRIDE
- 59 SOLENOID AIR PILOT WITH GROMMET CONN. AND LOCKING MAN. OVERRIDE
- 60 SOLENOID AIR PILOT WITH GROMMET CONN.
- 61 SOLENOID AIR PILOT WITH GROMMET CONN. AND MANUAL OVERRIDE
- 62 SOLENOID EXTERNAL AIR PILOT WITH GROMMET CONNECTION
- 63 SOLENOID EXTERNAL AIR PILOT WITH GROMMET CONNECTION AND MANUAL OVERRIDE
- 67 DIN CONNECTOR
- 68 DIN CONNECTOR WITH MANUAL OVERRIDE
- 82 DIN CONNECTOR WITH LOCKING MANUAL OVERRIDE
- 86 DIN CONNECTOR WITH MANUAL OVERRIDE EXTERNAL PILOT SUPPLY
- 67C DIN CONNECTOR
- 68C DIN CONNECTOR WITH MANUAL OVERRIDE
- 82C DIN CONNECTOR WITH LOCKING MANUAL OVERRIDE
- 86C DIN CONNECTOR WITH MANUAL OVERRIDE EXTERNAL PILOT SUPPLY

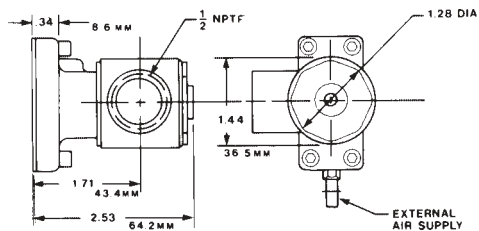
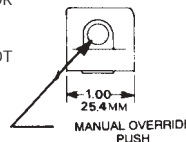

- 42 EXPLOSION PROOF SOLENOID
- 66 EXPLOSION PROOF SOLENOID WITH EXTERNAL AIR SUPPLY

| DESCRIPTION  | PIPE SIZE | NUMBER        |
|--|-----------|---------------|
| Single solenoid, spring return valve, base mounted, valve only |           | 375-02-004-37 |
| Side Ported Base   | 1/4 NPTF  | 375-1401      |
|  | 3/8 NPTF  | 375-1402      |
|  | 1/2 NPTF  | 375-1405      |
| Side & Bottom Ported Base                                      | 1/4 NPTF  | 375-1168      |

Note: Valves and bases must be ordered separately

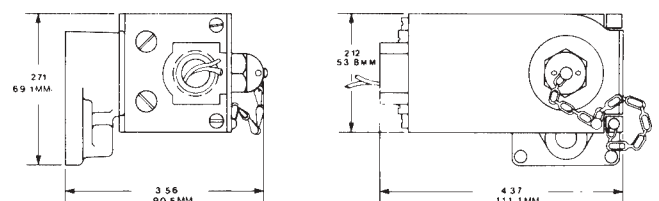

- 74 SOLENOID AIR PILOT J.I.C. NEMA 1 THROUGH 6 & 12

**NORMALLY CLOSED/NORMALLY OPEN VALVES**  
 Note: Unless otherwise specified, all 375 Series 3-way solenoid valves are supplied as Normally Closed and the #3 port is the supply port. If a Normally Open valve is required it must be specified and the #1 port must be piped as the supply port.  
 EXAMPLE: NO375-02-007-33 120/60

All solenoid operators available in the following voltages: 120/60, 240/60, 24/60, 6VDC, 12VDC, 24VDC, for other voltages, Class H, or low watt coils, consult factory.

## OMNI 375 SERIES VALVES

### 3-Way & 4-Way Air Pilot Operated

The Omni 375 Series 3-Way and 4-Way Valves can be Air Pilot Operated with three types of assembly:

- DOUBLE AIR PILOT (NO VALVE SPOOL SPRING)**  
The valve spool is shifted by a momentary air pilot signal to either of the "A" or "B" Pilots.
- SINGLE AIR PILOT, SPRING RETURN**  
The valve spool is maintained in the normal rest position by the spring in the "B" end. A maintained air pressure signal at the "A" end greater than the spring force will shift the valve spool.
- DOUBLE AIR PILOT, SPRING OFFSET**  
The valve spool is maintained in the normal rest position by a spring in the "B" end. A maintained air pressure signal at the "A" end greater than the spring force will shift the valve spool, providing no air pressure signal is on the "B" end. By controlling the pressure differential between "A" and "B", a variety of applications are possible.



#### 3-Way

#### Single Air Pilot

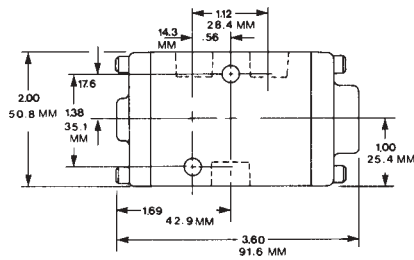

#### 03 Air Pilot

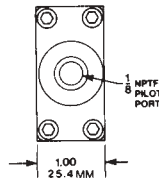

#### Double Air Pilot

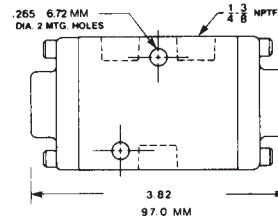

#### Single Air Pilot

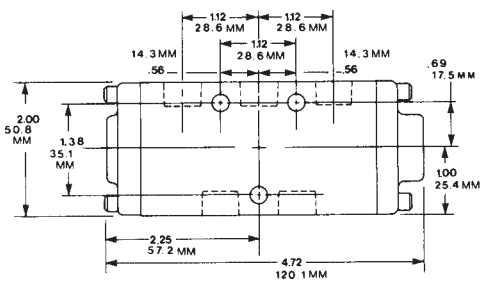

#### 03 Air Pilot

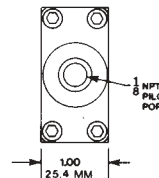

#### Double Air Pilot

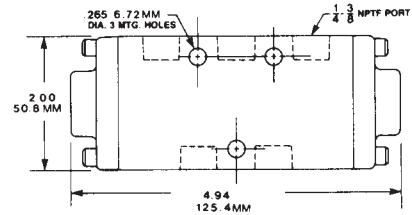

#### Base Mount

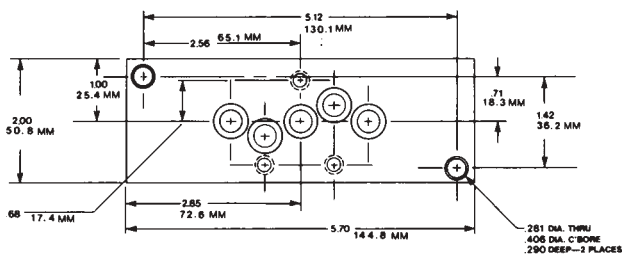
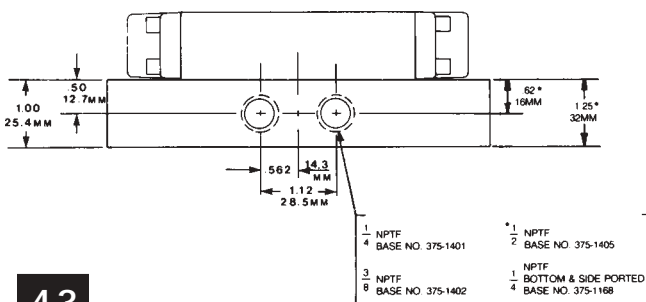



# OMNI 375 SERIES VALVES

# ALKON

## Basic Valve Model Numbers

| DESCRIPTION                    | 3-Way     |               |            | 4-Way     |               |            |
|--------------------------------|-----------|---------------|------------|-----------|---------------|------------|
|                                | PIPE SIZE | NUMBER        | SCHEMATICS | PIPE SIZE | NUMBER        | SCHEMATICS |
| Single Air Pilot Spring Return | 1/4 NPTF  | 375-02-007-03 |            | 1/4 NPTF  | 375-02-001-03 |            |
|                                | 3/8 NPTF  | 375-02-087-03 |            | 3/8 NPTF  | 375-02-081-03 |            |
| Double Air Pilot               | 1/4 NPTF  | 375-03-007-03 |            | 1/4 NPTF  | 375-03-001-03 |            |
|                                | 3/8 NPTF  | 375-03-087-03 |            | 3/8 NPTF  | 375-03-081-03 |            |
| Double Air Pilot Spring Biased | 1/4 NPTF  | 375-04-007-03 |            | 1/4 NPTF  | 375-04-001-03 |            |
|                                | 3/8 NPTF  | 375-04-087-03 |            | 3/8 NPTF  | 375-04-081-03 |            |

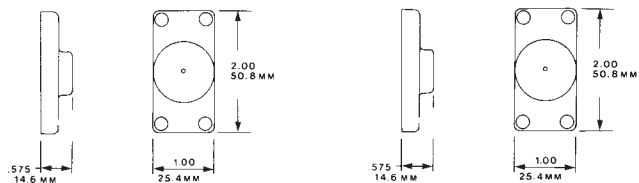

01 Blank End Cap

02 Spring End Cap

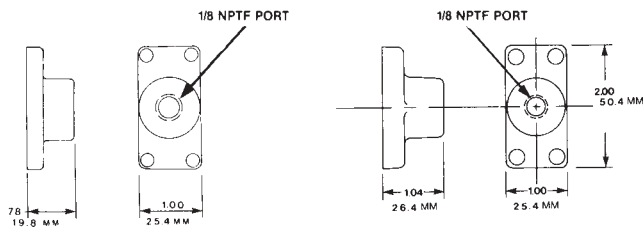

03 Air Pilot

04 Air Pilot with Spring Offset

This Series of 4-way valves is available with base mounting which permits the removal or changing of a valve without disturbing the piping. The 375 Series base is machined from extruded aluminum and available with 5 threaded ports in 1/4, 3/8 or 1/2 NPTF. The valve body (004) has 5 unthreaded ports on the wide part of the valve which mate with the five ports on the top of the base. The body is supplied with five Viton o-rings and is assembled to the base.

| DESCRIPTION  | PIPE SIZE | NUMBER        |
|--|-----------|---------------|
| Air pilot, spring return valve, base mounted, valve only |           | 375-02-004-03 |
| Side Ported Base   | 1/4 NPTF  | 375-1401      |
|  | 3/8 NPTF  | 375-1402      |
|  | 1/2 NPTF  | 375-1405      |
| Side & Bottom Ported Base                                | 1/4 NPTF  | 375-1168      |

Note: Valve and bases must be ordered separately

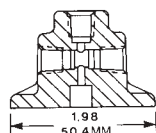
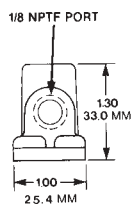

69 Air Pilot 3 Ported

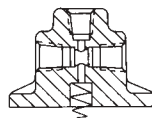

71 Air Pilot 3 Ported Spring

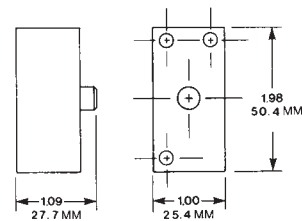

70 Shuttle with Auxiliary Outlet Plugged

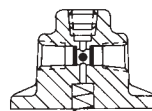
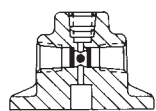

72 Shuttle with Auxiliary Outlet Plugged and Spring

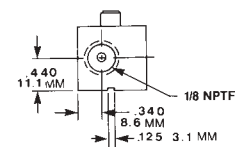

81 Auto Pilot with Spool Position Indicator/Manual Actuator



# OMNI 375 SERIES VALVES

## 3-Way & 4-Way Manually Operated

Many applications require hand and foot actuation. The OMNI 375 3-Ways and 4-Ways offer a rugged, compact, versatile answer. Mount them in any position. Available with levers, buttons, selectors or foot pedals with spring return or detent.



13 Lever

15 Lever

4-Way

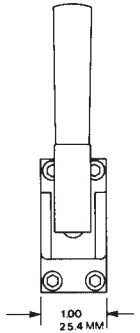
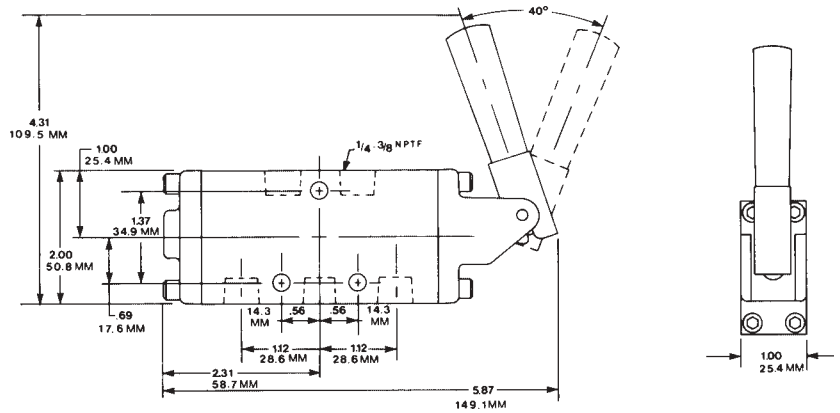
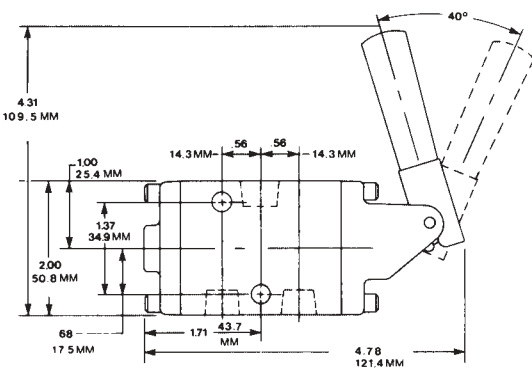

3-Way

09 Palm Button

4-Way

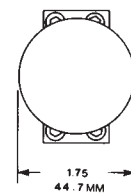
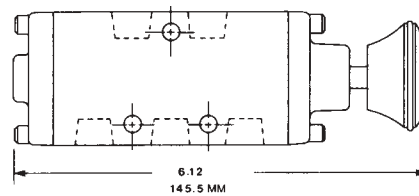
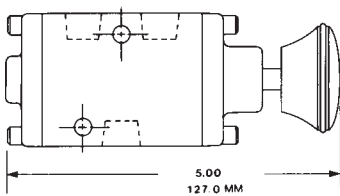

3-Way

4 Way

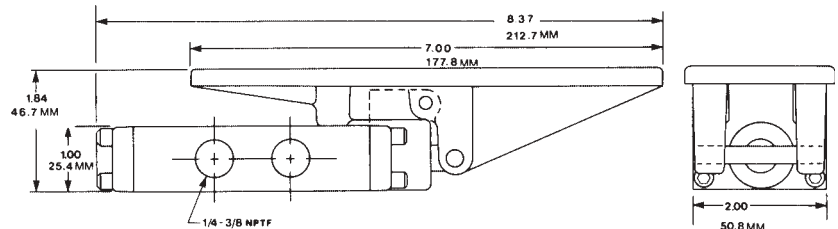
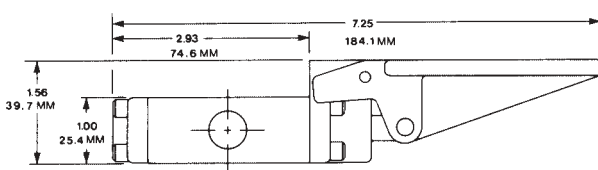

34 Pedal

39 Treadle Detented



## OMNI 375 SERIES VALVES

### Basic Valve Model Numbers

| DESCRIPTION                            | 3-Way     |               |            | 4-Way     |               |            |
|--|-----------|---------------|------------|-----------|---------------|------------|
|  | PIPE SIZE | NUMBER        | SCHEMATICS | PIPE SIZE | NUMBER        | SCHEMATICS |
| Palm Button Spring Return              | 1/4 NPTF  | 375-02-007-09 |            | 1/4 NPTF  | 375-02-001-09 |            |
|  | 3/8 NPTF  | 375-02-087-09 |            | 3/8 NPTF  | 375-02-081-09 |            |
| Parallel Side Lever with Spring Return | 1/4 NPTF  | 375-02-007-13 |            | 1/4 NPTF  | 375-02-001-13 |            |
|  | 3/8 NPTF  | 375-02-087-13 |            | 3/8 NPTF  | 375-02-081-13 |            |
| Foot Operated Spring Return            | 1/4 NPTF  | 375-02-007-34 |            | 1/4 NPTF  | 375-02-001-34 |            |
|  | 3/8 NPTF  | 375-02-087-34 |            | 3/8 NPTF  | 375-02-081-34 |            |

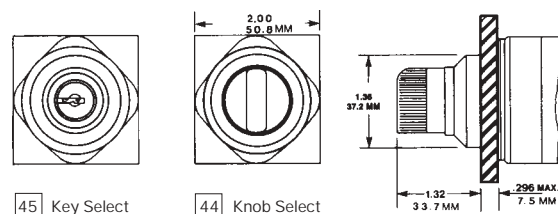
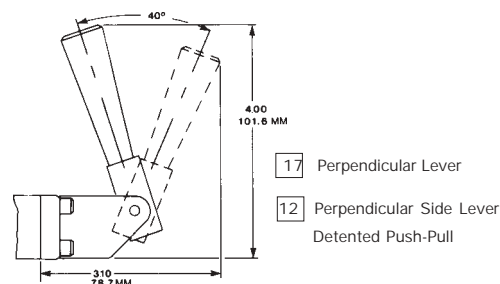
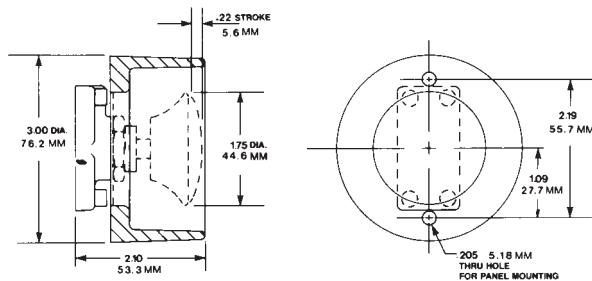
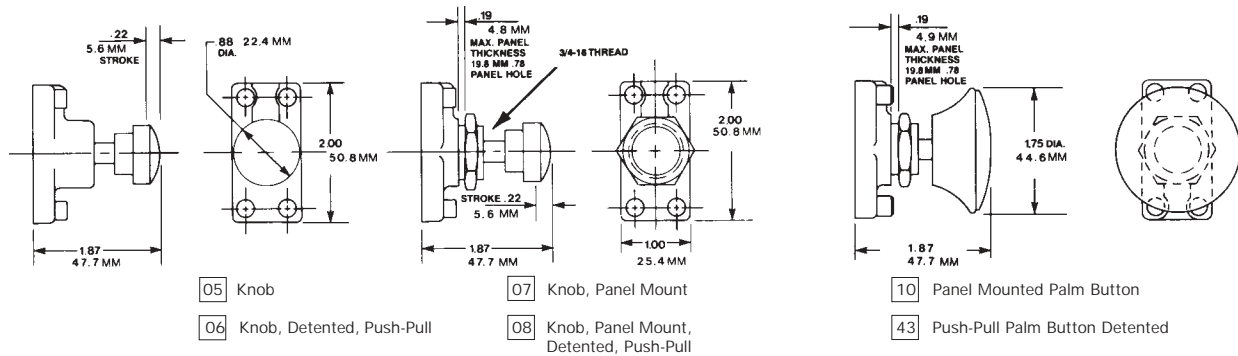

This Series of 4-way valves\* is available with base mounting which permits the removal or changing of a valve without disturbing the piping. The 375 Series base is machined from extruded aluminum and available with 5 threaded ports in 1/4, 3/8 or 1/2 NPTF. The valve body (004) has five unthreaded ports on the wide part of the valve which mate with five ports on the top of the base. The body is supplied with five Viton o'rings and is assembled to the base.

| DESCRIPTION   | PIPE SIZE | NUMBER        |
|---|-----------|---------------|
| Lever operated, spring return valve, base mounted, valve only |           | 375-02-004-17 |
| Side Ported Base  | 1/4 NPTF  | 375-1401      |
|   | 3/8 NPTF  | 375-1402      |
|   | 1/2 NPTF  | 375-1405      |
| Side & Bottom Ported Base                                     | 1/4 NPTF  | 375-1168      |

Note: Valve and bases must be ordered separately.

\*Because of operator overhang, not all operators available for base mount.



# OMNI 375 SERIES VALVES

## 3-Way & 4-Way Mechanically Operated



**CAM OPERATED:** The compact OMNI 375 is available with roller lever or steel plunger and can be mounted in any position... 375's can squeeze into tight places and deliver high flow.

**ROLLER LEVER ACTUATION:** 3 styles

1. Actuation right (roller lever moved to right operates valve)
2. Actuation left (roller lever moved to left operates valve)
3. 2-way actuation (when moved either direction operates valve)

The one-way model valve can be actuated in either direction without damage, but only the designated direction will operate valve. See diagrams below for clarification.

30 31 32 Roller Lever

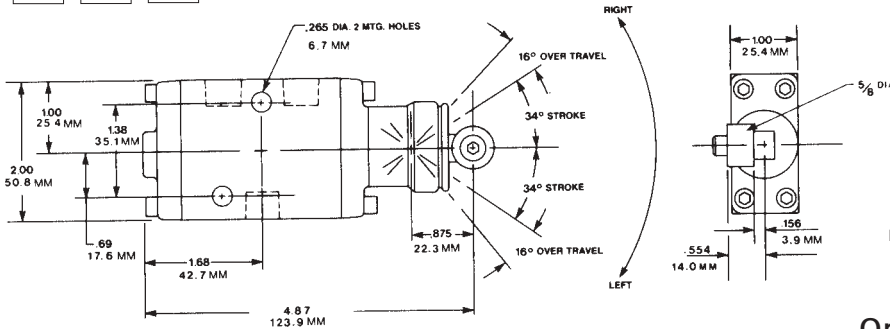

| OPERATORS |          |       |
|-----------|----------|-------|
| 30        | ACTUATES | LEFT  |
| 31        | ACTUATES | RIGHT |
| 32        | ACTUATES | BOTH  |

NOTE: 8-9 LB. ACTUATION FORCE REQUIRED ON ROLLER

### Ordering Information

3-Way 32 Plunger

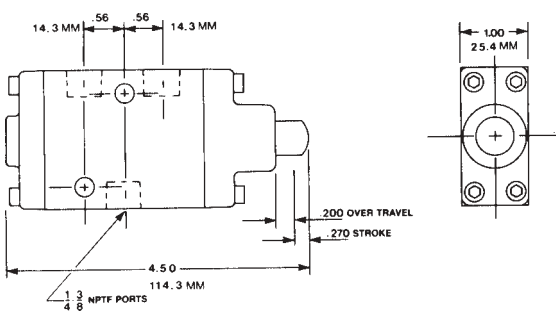

| DESCRIPTION  | 3-Way     |               |            |
|--|-----------|---------------|------------|
|  | PIPE SIZE | NUMBER        | SCHEMATICS |
| Parallel Roller Lever Actuating Left Spring Return | 1/4 NPTF  | 375-02-007-30 |            |
|  | 3/8 NPTF  | 375-02-087-30 |            |
| Steel Plunger Spring Return                        | 1/4 NPTF  | 375-02-007-27 |            |
|  | 3/8 NPTF  | 375-02-087-27 |            |

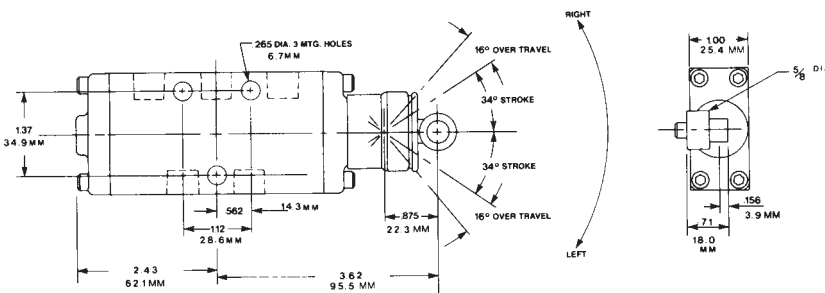

30 31 32 Roller Lever

### Ordering Information

4-Way 27 Plunger

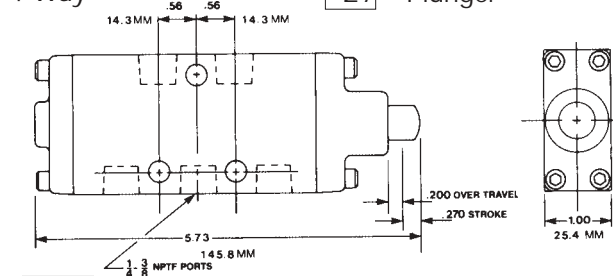

| DESCRIPTION  | 4-Way     |               |            |
|--|-----------|---------------|------------|
|  | PIPE SIZE | NUMBER        | SCHEMATICS |
| Parallel Roller Lever Actuating Left Spring Return | 1/4 NPTF  | 375-02-001-30 |            |
|  | 3/8 NPTF  | 375-02-081-30 |            |
| Steel Plunger Spring Return                        | 1/4 NPTF  | 375-02-001-27 |            |
|  | 3/8 NPTF  | 375-02-081-27 |            |



## OMNI 375 SERIES VALVES



Double Solenoid Spring Centered

### 3 Position Valves



Lever Operated Spring Centered

OMNI 375, 3-position valves are designed and engineered to the same standards and ideals of the industry proven and accepted 2-position series. 3-position valves are simple in design, compact, rugged and high flowing. These valves offer the following features:

| AIR FLOW DATA          |          |          |
|------------------------|----------|----------|
| Port Size              | 1/4 NPTF | 3/8 NPTF |
| Cv "E" spool           | 1.4      | 1.5      |
| Maxflow SCFM @ 80 PSIG | 68       | 71       |
| Cv "B" spool           | 1.4      | 1.5      |
| Maxflow SCFM @ 80 PSIG | 68       | 71       |
| Cv "P" spool           | 1.5      | 1.7      |
| Maxflow SCFM @ 80 PSIG | 71       | 79       |

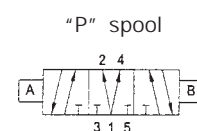
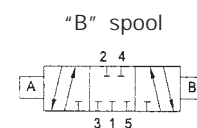
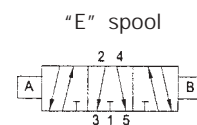

### ORDERING INFORMATION FOR 3-POSITION VALVES

Series      "B"      Body/Base      "A"      Volts/Hertz

**375** — **33T** — **E01** — **33T** — **120/60**

#### OPERATORS:

- Blank end cap for lever detented
- Spring centering for levers
- Spring centering air pilot
- Spring centering parallel side or straight lever
- Detented parallel side or straight lever
- Spring centering perpendicular side or straight lever
- Detented perpendicular side
- Spring centering solenoid air pilot w/ conduit connection
- Spring centering solenoid air pilot w/ conduit conn. & man. o'ride
- Spring centering solenoid air pilot w/ conduit conn. locking man. o'ride
- Spring centering explosion proof solenoid air pilot w/ conduit conn. & man. o'ride
- Spring centering solenoid air pilot w/ grommet connection
- Spring centering solenoid air pilot w/ grommet conn. & man. o'ride
- Spring centering solenoid external air pilot w/ grommet connection
- Spring centering solenoid external air pilot w/ grommet connection & man. o'ride
- Spring centering solenoid external air pilot w/ conduit connection
- Spring centering solenoid external air pilot w/ conduit connection & man. o'ride
- Spring centering solenoid air pilot w/ DIN connector
- Spring centering solenoid air pilot w/ DIN connector & man. o'ride
- DIN connector, locking man. o'ride

#### BODY STYLES

- |      |  |      |
|------|--|------|
| 01T_ | 1/4 NPTF individual 4-way blocked center     | B01_ |
| 02T_ | 1/4 NPTF individual 4-way exhausted center   | E01_ |
| 03T_ | 1/4 NPTF individual 4-way pressurized center | P01_ |
| 13T_ | 3/8 NPTF individual 4-way blocked center     | B81_ |
| 15T_ | 3/8 NPTF individual 4-way exhausted center   | E81_ |
| 17T_ | 3/8 NPTF individual 4-way pressurized center | P81_ |
| 19T_ | 1/4 NPTF stacking 4-way blocked center       | B03_ |
| 33T_ | 1/4 NPTF stacking 4-way exhausted center     | E03_ |
| 37T_ | 1/4 NPTF stacking 4-way pressurized center   | P03_ |
|      | 3/8 NPTF stacking 4-way blocked center       | B83_ |
| 38T_ | 3/8 NPTF stacking 4-way exhausted center     | E83_ |
|      | 3/8 NPTF stacking 4-way pressurized center   | P83_ |
| 42T_ | Manifold body w/ blocked center              | B08_ |
| 60T_ | Manifold body w/ pressurized center          | E08_ |
| 61T_ | Manifold body w/ exhausted center            | P08_ |
| 62T_ | Base mtd. body w/ blocked center             | B04_ |
|      | Base mtd. body w/ pressurized center         | E04_ |
|      | Base mtd. body w/ exhausted center           | P04_ |
- Standard voltages: 120/60, 240/60, 24/60, 6VDC, 12VDC, 24/VDC.
- Dimensional Data: For spring centered models, add .860" to comparable 2-position valve length.  
For detented models, add .060" to comparable 2-position valve length.



# OMNI 375 SERIES VALVES

## Stacking & Common Wireway Arrangements



The OMNI 375 Series valves can be assembled into a variety of stacking arrangements which greatly reduce piping requirements and increases mounting options. These stacks offer high flow performance in compact, space-saving packages which include:

- 2 and 3 position.
- Side or bottom porting - 1/4 or 3/8 NPTF
- 4-way, 5 ported stacks with common or dual input.
- Common or individual dual exhausts.
- Horizontal or vertical mounting.
- Grommet, conduit, or DIN connector for electrical operators.
- NEMA 4 common wireway closure.
- Electronic timer.



### Ordering Information

All OMNI 375 Series valve stacks and common wireway stacks are assembled with tie rods at the factory at no additional charge. The ordering procedure is very simple. First, list the quantity and model of each type of valve required. Second, determine the number of spacers required between each valve. When air pilot or DIN operated valves are used, spacers are not required. When manually operated valves are used, allow one spacer between each valve, but not between a valve and end plate. When solenoid operated valves are used (with or without manual override) allow one spacer between each valve, but not between a valve and end plate. For operators 42, 66, or 74, consult factory. Third, specify the type of end plate assembly required (side or bottom ported, 1/4 or 3/8 NPTF, horizontal or vertical). Fourth, for common wireway stacks, specify model enclosure. In most cases where a 3-way valve function is required in a stack, a pipe plug is used to block one of the cylinder ports.

Example for ordering two, 375 Series stacks with common wireway:

- (2) 375 Series common wireway stack consisting of:
  - (4) 375-02-009-68C 120/60 with lights
  - (1) 375-1230 side ported 1/4 NPTF end plate ass'y.
  - (1) 37-1122 NEMA 4 enclosure

Example for ordering two, 375 Series stacks:

- (2) 375 Series stack consisting of:
  - (3) 375-37-003-37 120/60
  - (2) 375-02-003-37 120/60
  - (4) 375-1240 Spacer Plates
  - (1) 375-1231 bottom ported 3/8 NPTF end plate ass'y.

NOTE: When ordering, if more than one model number valve is to be stacked specify valve position by numbering valves from left to right while facing the "B" end operators. If a vertical mounting plate is used, number valves starting from vertical plate.

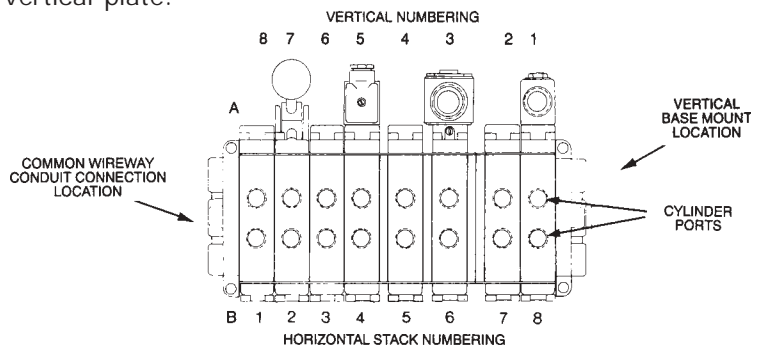



**ALKON**

# OMNI 375 SERIES VALVES

## Order Numbers For Common Wireway NEMA 4 Enclosure

| Description                                | Model   |
|--|---------|
| 2 valve, single solenoid enclosure         | 37-1200 |
| 2 thru 4 valves, double solenoid enclosure | 37-1123 |
| 5 thru 6 valves, single solenoid enclosure | 37-1124 |
| 5 thru 6 valves, double solenoid enclosure | 37-1125 |
| 7 thru 9 valves, single solenoid enclosure | 37-1127 |
| 7 thru 9 valves, double solenoid enclosure | 37-1128 |
| 10 + valves, consult factory               |         |

If any one valve in stack is double solenoid, you must order double solenoid enclosure

## Order Number For Common Wireway & Standard Stack End Plate Assemblies

| Description  | Model        |
|--|--------------|
| Vertical mount assembly (with 3/8 NPTF ports)                            | 375-1213-3/8 |
| Horizontal mount assembly (specify 1/4 or 3/8 NPTF) side ported plates   | 375-1230     |
| Horizontal mount assembly (specify 1/4 or 3/8 NPTF) bottom ported plates | 375-1231     |
| (For stacks only)  | 375-1240     |
| Spacer plate (For stacks only)   | 375-1240     |

### Common Wireway (NEMA 4)

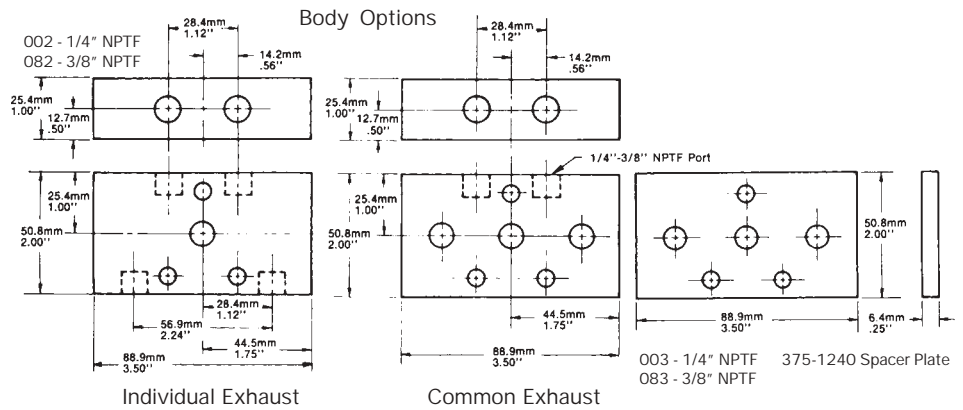
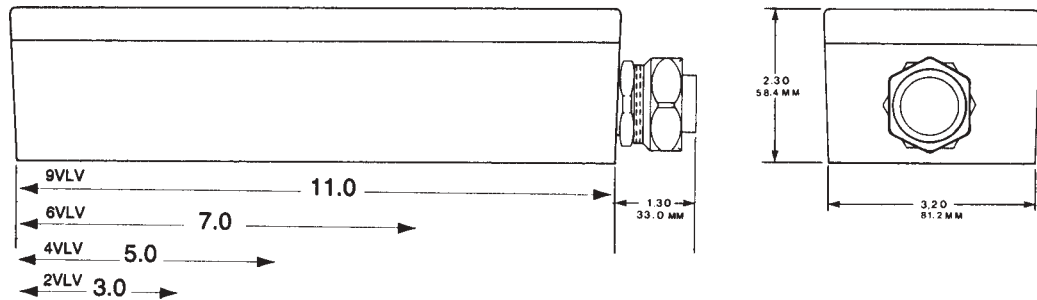

### End Plate Assemblies

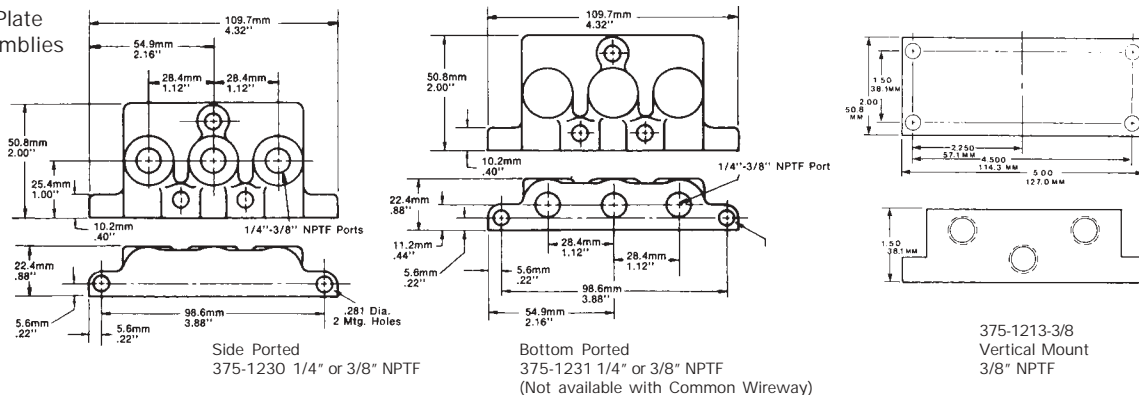

Note: End Plate Assemblies consist of the following: 2 end plates, 3 tie-rods and all nuts and o'rings needed.





## OMNI 375 SERIES VALVES

### Manifold Valves Ordering Information

To order an even number of valves, specify the required number of manifolds and valves.  
 For odd number of valves order a valve blank for one of the manifold stations, or an extra valve for emergency requirements.

### Order Numbers For Manifold Only

| Description   | Model    |
|---|----------|
| Two station manifold 1/4 NPTF ports, 1/8 NPTF pilot ports (for pilot application) complete with o'rings and tie bolts and tie down clamps.....                | 375-1164 |
| Two station manifold 3/8 NPTF ports, 1/8 NPTF pilot ports (for pilot application) complete with o'rings and tie bolts and tie down clamps.....                | 375-1166 |
| Right end plate (facing "B" end of manifold) complete with o'rings and hex head bolts 3/8 NPTF.....   | 375-1199 |
| Left end plate (facing "B" end of manifold) complete with hex lock nuts, no o'rings* 3/8 NPTF.....  | 375-1200 |
| Base Plate for vertical mounting of manifold 3/8 NPTF supply port. Complete with lock nuts and o'rings. (For other end of manifold use right end plate.)..... | 375-1300 |
| Tie-Down Clamp.....   | 375-1035 |
| Manifold with Dual Pressure 3/8 NPTF ports.....   | 375-1203 |
| Two Station Manifold, 3/8 NPTF ports, complete, for use with 4-2 operators.....   | 375-1591 |

### Ordering Sequence For Manifold And Valves

| Qty. | Description  |
|------|--|
| 1    | 375 Series Manifold assembly consisting of:<br>(4) 375-1164 manifold 1/4 NPTF<br>(7) 375-02M-008-68M valves 120/60<br>(1) 375-000 Valve Blank<br>(1) 375-1199 Right end plate<br>(1) 375-1200 Left end plate |

NOTE: If specific valve locations are required, please specify.  
 Blocking discs available to facilitate dual pressure, #32A01032

### Ordering Information For Manifold Mounted Valves Only



#### OPERATORS:

- Blank End Cap 01
- Spring Return 02
- Air Pilot 03M
- Air Pilot Spring offset 04M
- Lever, parallel 13
- Lever, parallel, detented 15
- Solenoid air pilot with conduit connection 33
- Solenoid air pilot with conduit connection and manual override 37
- Solenoid air pilot with conduit connection and locking manual override 38
- Solenoid with explosion-proof housing 42
- Micro timer-on delay w/ manual override & light 50
- Micro timer-off delay w/ manual override & light 51
- Micro timer-interval w/ manual override & light 52
- Micro timer-cycle w/ manual override & light 53

#### BODY

- 5 ported 4-way 008
  - Valve Blank 000
- (order as 375-000 for odd number valves)

#### OPERATORS:

- Solenoid air pilot with grommet conn. 60
  - Solenoid air pilot with grommet conn. and manual override 61
  - Solenoid external air pilot with grommet conn. (for low pressure or vacuum application) 62M
  - Solenoid external air pilot with grommet conn. & man. o'ride (for low pressure or vacuum application) 63M
  - Solenoid external air pilot with conduit conn. 64M
  - Solenoid external air pilot with conduit conn. and manual override 65M
  - Solenoid air pilot w/ DIN 67
  - Solenoid air pilot w/ DIN connector and manual override 68
  - Air pilot w/spool position indicator/man. actuator 81M
- Specify Voltage and Hertz of Solenoids



# OMNI 375 SERIES VALVES

Adjustable Electronic Micro Timer - .1 to 100 seconds

Timer styles available: On - delay  
Off - delay  
Interval  
Cycle - timer



## FEATURES: General Description

- Wide range of operating voltages, 6-24 VDC, 12, 24 & 120 VAC
- Timing circuit has typical temperature stability of .005% per deg. C at 25 deg. C.
- Wide range of adjustability, .1 to 100 seconds in various versions. For longer timing functions consult factory.
- Indicator lights available on all units.
- Solid state timer guarantees 500 KHz timing operation, no moving parts to wear out giving millions of trouble-free cycles.
- Operating temperature range, -20° to + 50° C
- Transient protection.
- High impact fiber-reinforced poly-amide nylon enclosure. Immersion resistant adjusting screws indicate adjustment extremes with a "tick" and can not be over adjusted. The recessed adjusting screws minimize tampering and can be epoxied over after final adjustment is made.
- 15 turn adjustability for time selection.
- All timers are available with electrical override.

Time Range: A = .1 - 5 seconds  
B = .5 - 20 seconds  
C = .5 - 40 seconds

### ON DELAY: 50 Operator

Upon application of power to the input terminals, the time delay begins. At the end of the preset time delay the coil becomes energized. Reset occurs when power is removed from the input terminals.

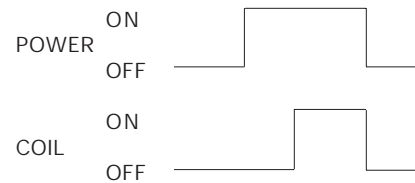

### OFF DELAY: 51 Operator

Power is applied to the timer at all times. Upon closure of the normally open trigger switch, coil becomes energized and timing begins. At the end of the preset time delay, power is removed from the coil. Reset occurs when trigger switch is closed.

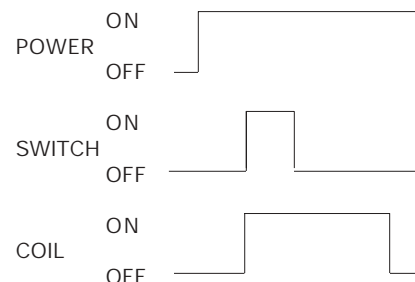

### INTERVAL: 52 Operator

Upon application of power, the coil is immediately energized and timing begins. At the end of the selected time, power is removed from the coil. Reset occurs when power is removed from the input terminals.

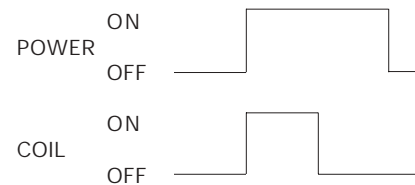

### CYCLE TIMER: 53 Operator

Upon application of power to the input terminals, OFF cycle is initiated. At the end of the preset off time, coil is energized and ON cycle begins. At the end of the preset on time, power is removed and a new cycle begins. Cycling continues until power is removed from input terminals.

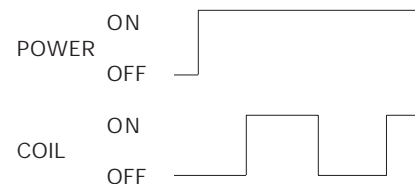



## OMNI 375 SERIES VALVES

### Replacement Parts

Operator No.

Spool Replacement\*

|                      |                                     |                                     |                                    |                                     |                                     |                                 |                                 |
|----------------------|-------------------------------------|-------------------------------------|------------------------------------|-------------------------------------|-------------------------------------|---------------------------------|---------------------------------|
| 06, 08, 43           |                                     |                                     |                                    |                                     |                                     |                                 |                                 |
|                      | <b>3-WAY 2 POSITION</b><br>90A20095 | <b>4-WAY 2 POSITION</b><br>90A20106 |                                    |                                     |                                     |                                 |                                 |
| 13, 17               |                                     |                                     |                                    |                                     |                                     |                                 |                                 |
|                      | <b>3-WAY 2 POSITION</b><br>90A20078 | <b>4-WAY 2 POSITION</b><br>90A20075 | <b>3 POSITION B</b><br>90A20182    | <b>3 POSITION E</b><br>90A20183     | <b>3 POSITION P</b><br>90A20184     |                                 |                                 |
| 15, 19               |                                     |                                     |                                    |                                     |                                     |                                 |                                 |
|                      | <b>3-WAY 2 POSITION</b><br>90A20112 | <b>4-WAY 2 POSITION</b><br>90A20113 | <b>3 POSITION B</b><br>90A20185    | <b>3 POSITION E</b><br>90A20186     | <b>3 POSITION P</b><br>90A20187     |                                 |                                 |
| FOOT PEDAL<br>34, 39 |                                     |                                     |                                    |                                     |                                     |                                 |                                 |
|                      | <b>3-WAY 2 POSITION</b><br>90A20116 | <b>4-WAY 2 POSITION</b><br>90A20117 |                                    |                                     |                                     |                                 |                                 |
| 42, 74               |                                     |                                     |                                    |                                     |                                     |                                 |                                 |
|                      | <b>SINGLE SOLENOID</b><br>90A20076  | <b>DOUBLE SOLENOID</b><br>90A20205  | <b>SINGLE SOLENOID</b><br>90A20075 | <b>DOUBLE SOLENOID</b><br>90A20132  | <b>3 POSITION B</b><br>90A20188     | <b>3 POSITION E</b><br>90A20189 | <b>3 POSITION P</b><br>90A20190 |
| 27, 30, 31, 32       |                                     |                                     |                                    |                                     |                                     |                                 |                                 |
|                      | <b>3-WAY 2 POSITION</b><br>90A20201 | <b>4-WAY 2 POSITION</b><br>90A20127 |                                    |                                     |                                     |                                 |                                 |
| ALL OTHERS           |                                     |                                     |                                    |                                     |                                     |                                 |                                 |
|                      | <b>3 POSITION B</b><br>90A20175     | <b>3 POSITION E</b><br>90A20176     | <b>3 POSITION P</b><br>90A20177    | <b>3-WAY 2 POSITION</b><br>90A20078 | <b>4-WAY 2 POSITION</b><br>90A20075 |                                 |                                 |

\* Material: Aluminum is standard. Derlin available on some operators. Consult factory.

### Coil Replacement

| Description   | Molded   |
|---|----------|
| Coil with conduit housing<br>33, 37, 38, 64, 65 operators, 7 watt | 26A01017 |
| Coil with grommet housing<br>59, 60, 61, 62, 63 operators, 7 watt | 26A01033 |
| Coil only for J.I.C. housing<br>74 operator                       | 26A01000 |
| Coil for explosion proof housing<br>42, 66 operators, 7 watt      | 26A01043 |
| Coil for DIN connector, 8.5 watt                                  | 26A01039 |

Torque Settings for Coil Hold Down Nuts Are:  
20-25 in-lbs. for Canned type operators  
20-25 in-lbs. for DIN operators  
55 in-lbs. for operators 42

When ordering coil, give part no. and voltage. Standard voltages are; 120/60, 240/60, 24/60, 6VDC, 12VDC, 24VDC. For other voltages consult factory.



# OMNI 500 SERIES VALVES Flow Rating: 5.0 CV (17.15 dm<sup>3</sup>/s)

## ORDERING INFORMATION

**E - 500 - 02 - - 041 - 37 - L - 1**

### VOLTAGES

1. 120/60 AC\*
2. 12 VDC\*
3. 24/60 AC\*
4. 240/60 AC\*
5. 24 VDC\*

\* Denotes standard voltages - others on request.

### OPERATOR SUFFIX - OPTIONAL

OPERATOR "A" (see listing)

### BODIES

#### First Digit

#### Center Position

- O = None
- B = Blocked
- E = Exhausted
- P = Pressurized

#### Second Digit

#### Port Size

- 4 = 1/2 NPT
- 6 = 3/4 NPT

#### Third Digit

#### Body Style/Type

- 0 = Body Blank, 4-Way
- 1 = Inline, 4-Way
- 3 = Stacking, 4-Way
- 9 = Stacking, 4-Way  
Common wireway  
mount

### OPERATOR SUFFIX - OPTIONAL

OPERATOR "B" (See Listing)

SERIES (500)

Use when ordering metric ports only

### Ordering Procedure for OMNI 500 Series

1. Code: E - Use when ordering metric ports only
2. Series: Identifies valve series
3. "B" Operator: Secondary operator - returns spool  
Operator suffix if applicable
4. Body Style: OMNI 500 is a 2 or 3 position valve.  
The body style selects type of mounting & port sizes
5. "A" Operator: Primary operator moves spool away from  
start position.  
Operator suffix if applicable
6. Specify voltage from chart

### OPERATOR SUFFIX - OPTIONAL

| Letter Code | Description                                       | Availability                |
|-------------|---|-----------------------------|
| E           | External Air                                      | For unassigned operator #'s |
| F           | Filtered & Potted Solenoid<br>for NEMA 4 Solenoid | 33, 37, 38, 64, 65          |
| H           | Class H Coil, Viton<br>Sleeve & Plunger           | 33, 37, 38, 64, 65          |
| L           | Lighted Connector                                 | 33, 37, 67, 68, 82, 86      |
| R           | Red, HD Spring                                    | 02, 04                      |

### OPERATOR

- |  |   |
|--|---|
| 02 Spring Return   | 60 Solenoid grommet coil with lead wires  |
| 03 Air Pilot   | 61 Solenoid grommet coil with lead wires, manual override   |
| 33 Solenoid with 1/2" conduit connection   | 62 Solenoid grommet coil with lead wires and external pilot supply                                |
| 37 Solenoid with 1/2" conduit connection & manual override   | 63 Solenoid grommet coil with lead wires, manual override,<br>external pilot supply               |
| 38 Solenoid with 1/2" conduit connection & locking manual override                                     | 64 Solenoid with 1/2" conduit connection & external pilot supply                                  |
| 42 Solenoid - explosion proof, conduit connection, manual override                                     | 65 Solenoid with 1/2" conduit connection, manual override,<br>external pilot supply               |
| 50 Solenoid Micro timer - On delay, lighted, manual<br>override (see catalog for ranges - add suffix)  | 66 Solenoid - Explosion proof, 1/2" conduit connection, manual<br>override, external pilot supply |
| 51 Solenoid Micro timer - Off delay, lighted, manual<br>override (see catalog for ranges - add suffix) | 67 Solenoid with DIN connector  |
| 52 Solenoid Micro timer - Interval, lighted, manual<br>override (see catalog for ranges - add suffix)  | 68 Solenoid with DIN connector & manual override  |
| 53 Solenoid Micro timer - Cycle, lighted, manual<br>override (see catalog for ranges - add suffix)     | 82 Solenoid with DIN connector, locking manual override   |
|  | 86 Solenoid with DIN connector, manual override,<br>external pilot supply                         |



## OMNI 500 SERIES VALVES

The OMNI 500 Offers These Special Features:



- Up to 5.0 Cv flow.
- All coils molded epoxy - standard.
- Dual rated solenoids for 50/60 cycles.
- A variety of standard AC or DC voltage options.
- Plug-in electrical connectors.
- Explosion proof operators.
- Electronic Micro Timers.
- Built to equal or exceed US & CSA standards.
- For lubed or non-lubed applications.
- Class H Hi-Temp solenoid available.

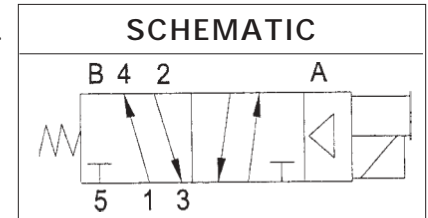

Single Solenoid / Spring Return

### End Caps (In-Line)

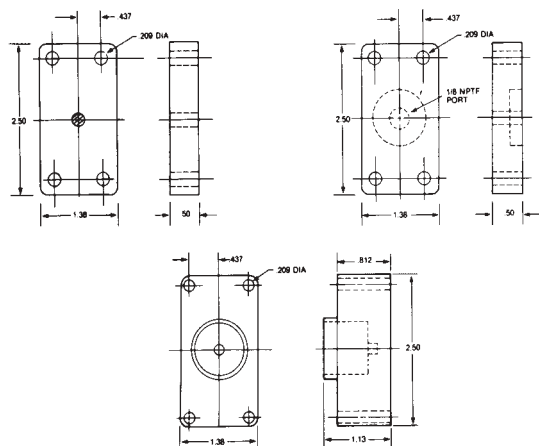

### End Caps (Stacking)

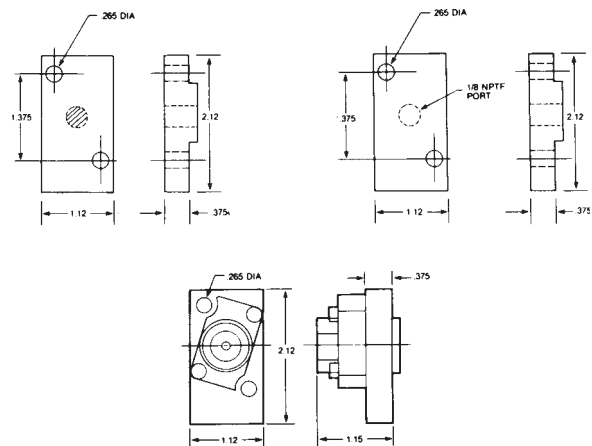

### Operators Solenoid for stacking of in-line valve end caps

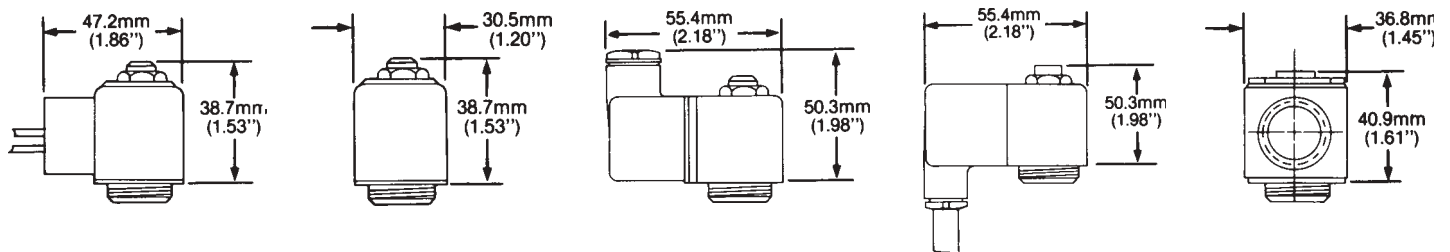

- |    |   |    |   |    |   |     |   |    |   |
|----|---|----|---|----|---|-----|---|----|---|
| 33 | SOLENOID AIR PILOT CONDUIT CONNECTION                                   | 60 | SOLENOID AIR PILOT WITH GROMMET CONNECTION                              | 67 | DIN CONNECTOR   | 67C | DIN CONNECTOR   | 42 | EXPLOSION PROOF SOLENOID                          |
| 37 | SOLENOID AIR PILOT WITH MANUAL OVERRIDE                                 | 61 | SOLENOID AIR PILOT WITH GROMMET CONNECTION AND MANUAL OVERRIDE          | 68 | DIN CONNECTOR WITH MANUAL OVERRIDE                        | 68C | DIN CONNECTOR WITH MANUAL OVERRIDE                        | 66 | EXPLOSION PROOF SOLENOID WITH EXTERNAL AIR SUPPLY |
| 64 | SOLENOID EXTERNAL AIR PILOT WITH CONDUIT CONNECTION                     | 62 | SOLENOID EXTERNAL AIR PILOT WITH CONDUIT CONNECTION                     | 82 | DIN WITH LOCKING MANUAL OVERRIDE                          | 82C | DIN WITH LOCKING MANUAL OVERRIDE                          |    |   |
| 65 | SOLENOID EXTERNAL AIR PILOT WITH CONDUIT CONNECTION AND MANUAL OVERRIDE | 63 | SOLENOID EXTERNAL AIR PILOT WITH GROMMET CONNECTION AND MANUAL OVERRIDE | 86 | DIN CONNECTOR WITH MANUAL OVERRIDE. EXTERNAL PILOT SUPPLY | 86C | DIN CONNECTOR WITH MANUAL OVERRIDE. EXTERNAL PILOT SUPPLY |    |   |
| 38 | SOLENOID AIR PILOT MANUAL OVERRIDE                                      |    |   |    |   |     |   |    |   |



# ALCON OMNI 500 SERIES VALVES

1/2" Valve Bodies (In-Line) 3.8 Cv  
 3/4" Valve Bodies (In-Line) 5.0 Cv

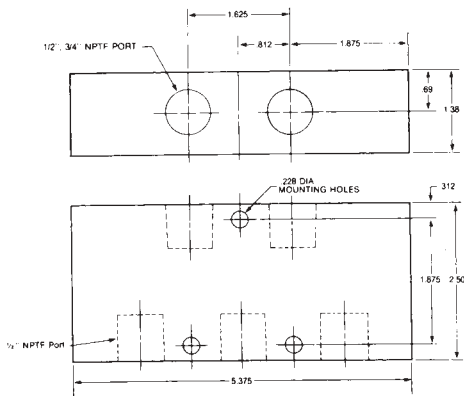

IN-LINE BODY

1/2" Valve Bodies (Stacking) 5.0 Cv

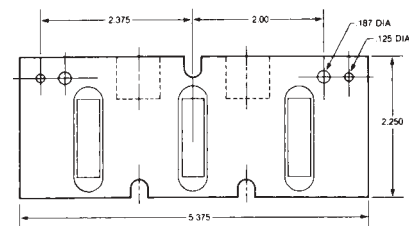
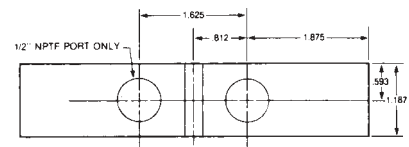

STACKING BODY

## Stacking Order Information

All OMNI series valve stacks and common wireway stacks are assembled with tie rods at the factory at no additional charge. The ordering procedure is very simple.

- First** List the quantity and model of each type of valve required.
- Second** When using a 42 operator, only one spacer is required per valve.
- Third** For common wireway stacks, specify model enclosure. In most cases where a 3-way valve function is required in a stack, a pipe plug is used to block one of the cylinder ports.
- Fourth** Callout stacking base plate assembly (vertical only) #500-1223.\*

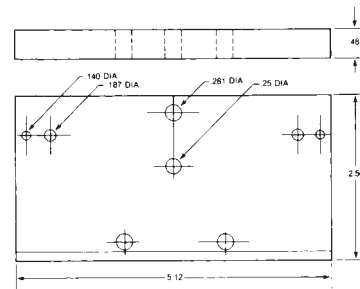

STACKING TOP PLATE

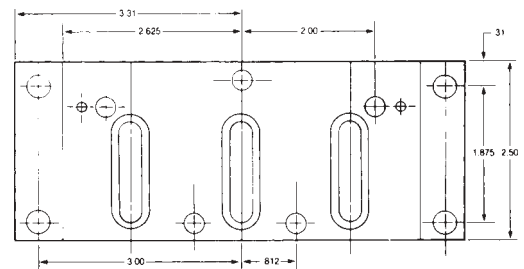

STACKING BASE PLATE

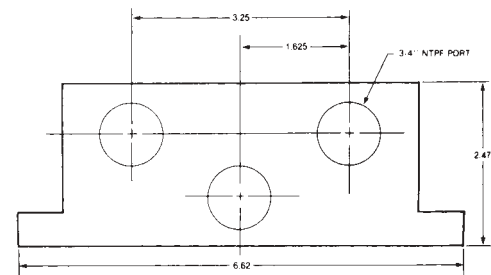

STACKING SPACER

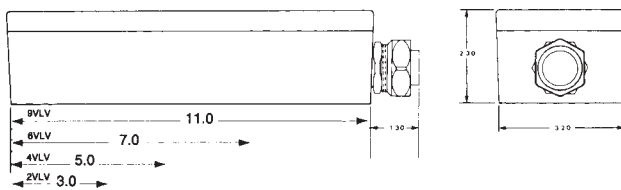

**Note:** 2 Valve Stacks with common wireway must have 1 pc #45A01095 spacer.

## Order Numbers for Common Wireway Enclosures

| Description                                   | Model   |
|---|---------|
| 2 valves, single solenoid enclosure           | 50-1192 |
| 2 valves, double solenoid enclosure           | 50-1193 |
| 3 and 4 valves, single solenoid enclosure     | 50-1194 |
| 3 and 4 valves, double solenoid enclosure     | 50-1195 |
| 5 valves, single solenoid enclosure           | 50-1196 |
| 5 valves, double solenoid enclosure           | 50-1197 |
| 6 through 8 valves, single solenoid enclosure | 50-1198 |
| 6 through 8 valves, double solenoid enclosure | 50-1199 |

**\*Note:** Vertical base assembly consists of base plate, top plate, bolts and o-rings.



# ALKON

## STAINLESS STEEL 316 SERIES

### POWER & CONTROL AIR VALVES

#### BODY DIMENSIONS

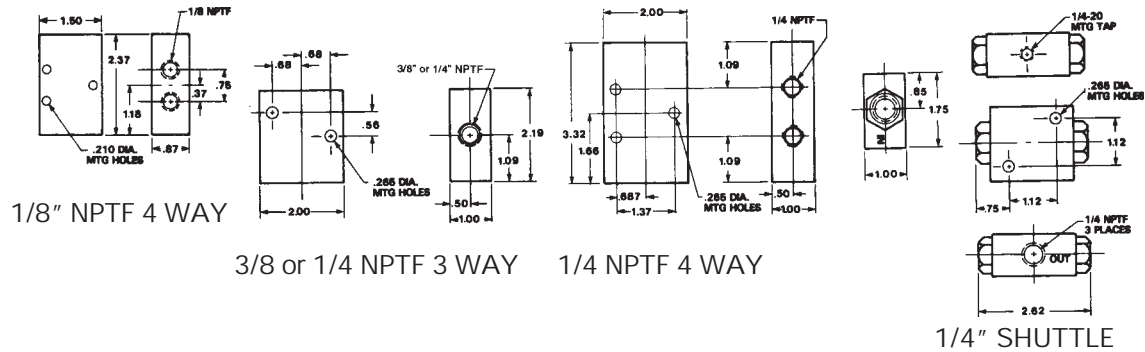

#### OPERATOR DIMENSIONS

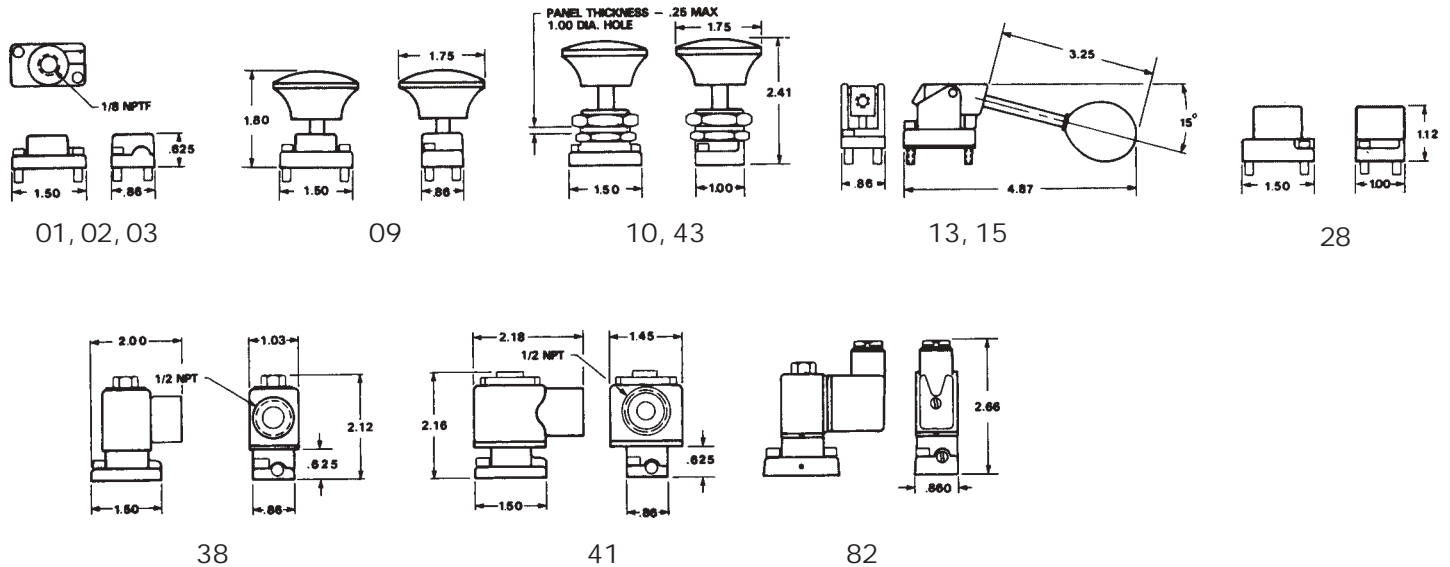

#### 316 SHUTTLE VALVE

SV-25-SS 1/4 NPTF shuttle valve (piston type)

#### END PLATES

| Number   | Description   |
|----------|---|
| 316-1230 | Side ported end plate assembly consisting of two end plates, o'rings, tie rods, nuts. |

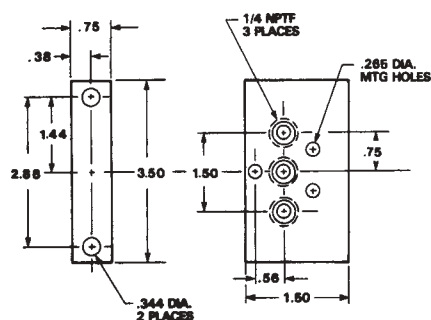

#### SPACERS

| Number   | Description   |
|----------|---|
| 316-1240 | Delrin spacer for valves with 38, 41, and other operators whose width is greater than the valve body width. Includes o'rings. |

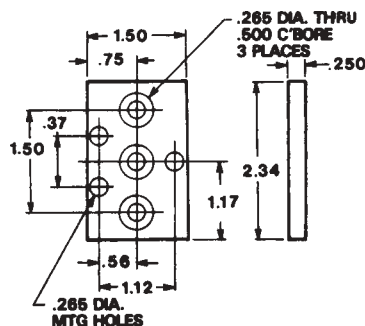

### ORDERING INFORMATION

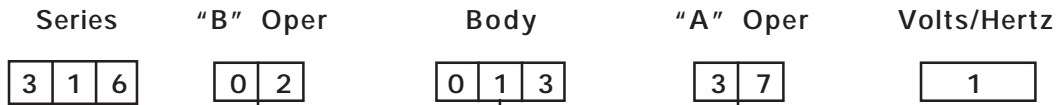

#### Ordering Procedure for Stainless Series 316

- Series Designation  
316 identifies 316 series stainless.
- "B" Operator  
This is the secondary operator. The secondary operator returns the spool.
- Body Style  
1/8" body available in 4-way only, but can be plugged to make 3-way or 2-way.
- "A" Operator  
This is the primary operator. The primary operator moves the spool away from the start position.
- Specify voltages or any other special conditions.

#### OPTIONS:

- Class H. coils.
- Din connector with light available.
- Intrinsically Safe Solenoids available.

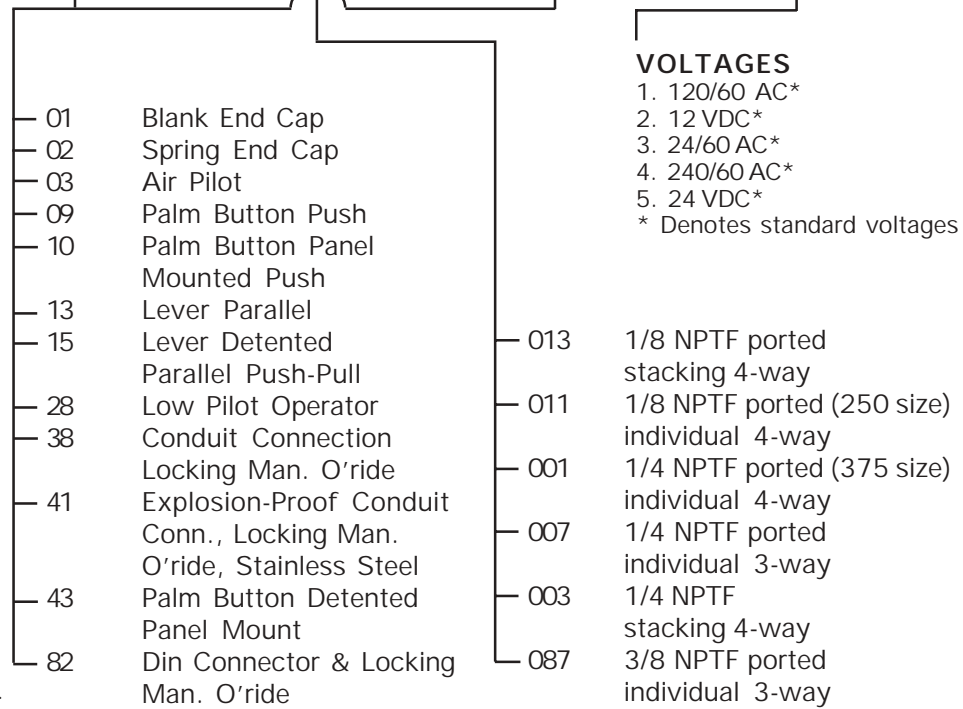

#### VOLTAGES

- 120/60 AC\*
  - 12 VDC\*
  - 24/60 AC\*
  - 240/60 AC\*
  - 24 VDC\*
- \* Denotes standard voltages





## STAINLESS STEEL 316 SERIES

### ENGINEERING & TECHNICAL DATA

#### MATERIAL

316 Series - Metal components are 316 stainless steel excluding standard solenoid operator.

#### BODY STYLE

1/8 NPTF ported - 2-way and 3-way bodies are 4-way bodies with plugged ports.

1/4 NPTF ported - 3-way bodies and 4-way bodies.

3/8 NPTF ported - 3-way bodies only.

#### CONFIGURATIONS

Solenoid, air, and manual actuators, In-line, and stacking bodies.

#### LUBRICATION

All valves are pre-lubricated and will operate dry (with no additional lubrication). However, a lubricated system will greatly extend the service life of any valve.

#### "THIN-LIP" SEAL & SPOOL

- PTFE loaded Viton seals provide millions of trouble-free cycles.
- Minimal breakout friction.
- Unique wiping action eliminates contaminate build-up in bore.
- Reduces spool hang-up due to compressor or oil varnishing.
- Operates effectively in lubricated or non-lubricated systems.

### VALVE OPERATING SPECIFICATIONS

**Media:** Air & Gas

**Pressure Range:**

Main Supply: 40 - 150 psig (standard)  
Vacuum to 40 psig is available

Sol. Pilot Air: Minimum 40 psig to 150 psig and not less than the main air supply.

For lower pilot pressure consult factory.

**Temperature Range:** 0° C to 85° C  
32° F to 180° F

For other temperatures consult factory.

#### FLOW DATA

| Port          | CV  | SCFM at 80 psi |
|---------------|-----|----------------|
| 1/8 NPT       | 1.1 | 52             |
| 3/8 & 1/4 NPT | 2.2 | 104            |

### REPLACEMENT PARTS

#### SPOOL REPLACEMENT

##### Air & Solenoid

##### S.S.

|                |                                 |          |
|----------------|---------------------------------|----------|
| 1/8 NPTF       | Single & double pilot           | 90A20295 |
| 1/4 NPTF       | Single & double pilot           | 90A20237 |
| 1/4 NPTF 3-way | Single & double pilot           | 90A20247 |
| 1/4 NPTF 3-way | Push palm button                | 90A20248 |
| 1/4 NPTF 3-way | Push palm button panel mtd.     | 90A20249 |
| 1/4 NPTF 3-way | Detented palm button panel mtd. | 90A20250 |
| 1/4 NPTF 3-way | Lever palm button panel mtd.    | 90A20251 |

### SOLENOID DATA

| Standard Voltages | Current (Amps) |         |
|-------------------|----------------|---------|
|                   | Inrush         | Holding |
| 120/60AC          | .11            | .07     |
| 110/50AC          | .13            | .08     |
| 240/60AC          | .06            | .03     |
| 215/50AC          | .06            | .04     |
| 24/60AC           | .6             | .3      |
| 12VDC             | .48            | .48     |
| 24VDC             | .29            | .29     |

Other AC and DC voltages available upon request.

**Note:** 120/60Hz can be connected to 110/50Hz.  
240/60Hz can be connected to 215/50Hz.

Molded epoxy coils standard.

Explosion-proof solenoids available.

### SOLENOID HOUSING CLASSIFICATIONS

#### Conduit and Grommet Housings with Molded Coils Meet:

|         |   |
|---------|---|
| NEMA 1  | General Purpose - Indoors   |
| NEMA 2  | Dripproof - Indoors   |
| NEMA 3  | Driptight - Indoors   |
| NEMA 4* | Watertight & Dusttight - Indoors & Outdoors                                   |
| NEMA 6* | Submersible, Watertight, Dusttight & Sleet-Ice Resistant - Indoors & Outdoors |

\*Specify "Potted" Coil Option to meet NEMA 4 & 6

#### Explosion Proof Housings Meet:

|                       |   |
|-----------------------|---|
| NEMA 7C, 7D & CSA     | Class I - Groups C & D- Explosion Proof     |
| NEMA 8C, 8D & CSA     | Class I - Groups C & D- Explosion Proof     |
| NEMA 9E, 9F, 9G & CSA | Class II - Groups E, F & G- Explosion Proof |

#### J.I.C. Housings & DIN Operators Meet:

|           |   |
|-----------|---|
| NEMA 3 R  | Rainproof & Sleet-(Ice) Resistant - Outdoors  |
| NEMA 3 S  | Dusttight, Raintight, Sleet & Ice Proof - Outdoors  |
| NEMA 4*   | Watertight & Dusttight - Indoors & Outdoors   |
| NEMA 4 X* | Watertight & Dusttight & Corrosion Resistant - Indoors & Outdoors                         |
| NEMA 6    | Submersible, Watertight & Dusttight - Indoors; Sleet & Ice Resistant - Indoors & Outdoors |
| NEMA 12   | Industrial Use - Dusttight & Driptight - Indoors  |
| NEMA 13   | Oiltight & Dusttight - Indoors  |

\*DIN operators meet IP • 65, for NEMA ratings please specify "NEMA 4" option.

### COIL REPLACEMENT

#### Description

#### Model

|                                  |              |          |
|----------------------------------|--------------|----------|
| Coil with conduit housing        | 38 operators | 26A01017 |
| Coil with DIN connector          | 68, 82       | 26A01039 |
| Coil for explosion-proof housing | 41 operators | 26A01043 |

When ordering coil give part no. and voltage. Standard voltages are: 120/60, 240/60, 6VDC, 12VDC, 24VDC. For other voltages, consult factory.

### OPERATOR REPLACEMENT

For all valves, furnish operator number only.

**Example:** 316-38 operator 120/60



# LOC-MASTER®

## SAFETY LOCK OUT & EXHAUST AIR VALVES MANUAL & ELECTRIC

SIZES AVAILABLE: 3/8, 1/2, 3/4, 1, 1 1/4, 2 & 2-1/2" NPTF



### Operation- Loc-Master (LM)

Push handle in and one quarter turn to detent - inlet open to outlet, exhaust blocked.

One quarter turn of operating stem from detent position allows valve to spring return, shutting off supply and simultaneously exhausts downstream air not trapped by some other system component

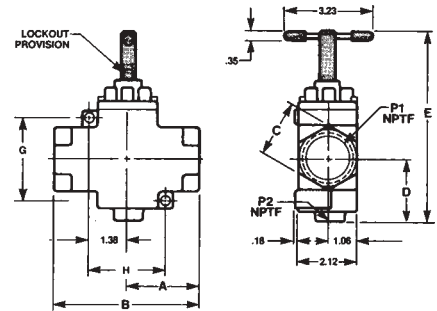

### Operation- Quick Loc-Master (QLM)

Quick Loc-Master with ball handle operates same as above (LM) except actuation and de-actuation take place in 45° increments to allow for even quicker shut off.

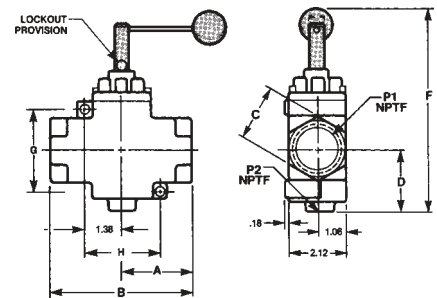

### Operation- Slow Loc-Master (SLM)

Slow Loc-Master is designed to allow operator to control rate of air flow when charging or exhausting a pneumatic system. Three full turns of knob are required to open valve fully and three full turns in opposite direction to close valve and exhaust downstream air. After system is charged, valve should always be placed in full open position for best operation.

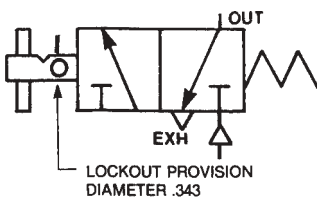
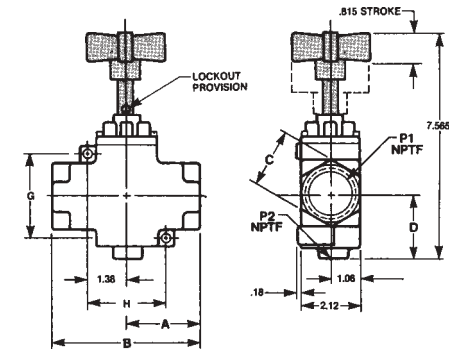

Loc-Master has long been industry's first choice in safety bleed valves; available in 3/8, 1/2, 3/4, 1 & 1-1/4 NPTF sizes. All valves have telescoping handle and provision for locking in off position only.

### Specifications

- 0 - 150 psig
- 40 Micron Filtration
- Viton Seals
- 40° to 180° F

### Flow Data

|       |     | S.C.F.M.<br>ATMOSPHERE |             |
|-------|-----|------------------------|-------------|
| NPT   | Cv  | @ 80 P.S.I.G. WEIGHT   |             |
| 3/8   | 4.2 | 191                    | 1 lb. 8 oz. |
| 1/2   | 5.3 | 242                    | 1 lb. 8 oz. |
| 3/4   | 11  | 495                    | 2 lb.       |
| 1     | 14  | 647                    | 2 lb.       |
| 1-1/4 | 14  | 647                    | 2 lb.       |

### INSTALLATION DATA (in inches)

| MODEL NUMBER          | P1 NPTF IN-OUT | P2 NPTF | A    | B    | C    | D    | E    | F    | G     | H     | I     | J   |
|-----------------------|----------------|---------|------|------|------|------|------|------|-------|-------|-------|-----|
| LM37 QLM 37 -         | 3/8            | 1/4     | 2.08 | 4.16 | 1.37 | 1.60 | 5.75 | 6.00 | 2.125 | 2.625 | 1.312 | .15 |
| LM50 QLM 50 -         | 1/2            | 1/4     | 2.08 | 4.16 | 1.37 | 1.60 | 5.75 | 6.00 | 2.125 | 2.625 | 1.312 | .15 |
| LM75 QLM 75 SLM 75    | 3/4            | 1/2     | 2.72 | 5.43 | 2.12 | 2.39 | 6.90 | 6.90 | 2.719 | 2.686 | 1.343 | .18 |
| LM100 QLM 100 SLM 100 | 1              | 1/2     | 2.72 | 5.43 | 2.12 | 2.39 | 6.90 | 6.90 | 2.719 | 2.686 | 1.343 | .18 |
| LM125 QLM 125 SLM 125 | 1-1/4          | 1/2     | 2.72 | 5.43 | 2.12 | 2.39 | 6.90 | 6.90 | 2.719 | 2.686 | 1.343 | .18 |



**ALCON**

## MINI BAZOOKA LOC-MASTER®

Mini Bazooka and Big Bazooka Loc-Master valves are ported 1, 1-1/4, 1-1/2, 2 and 2-1/2 NPTF to be used as system supply valves and in applications requiring high air flow capacity. The valves are 3-way normally closed and operated by integral manual pilot valves. The pilot valves can be locked in the off position only.



### Operation

Push handle in and one quarter turn to detent port 1 open to port 2, port 3 is blocked. One quarter turn of handle from detent allows valve to spring return shifting off port 1 and opening port 2 to port 3 exhaust downstream air (not trapped by some other system component).

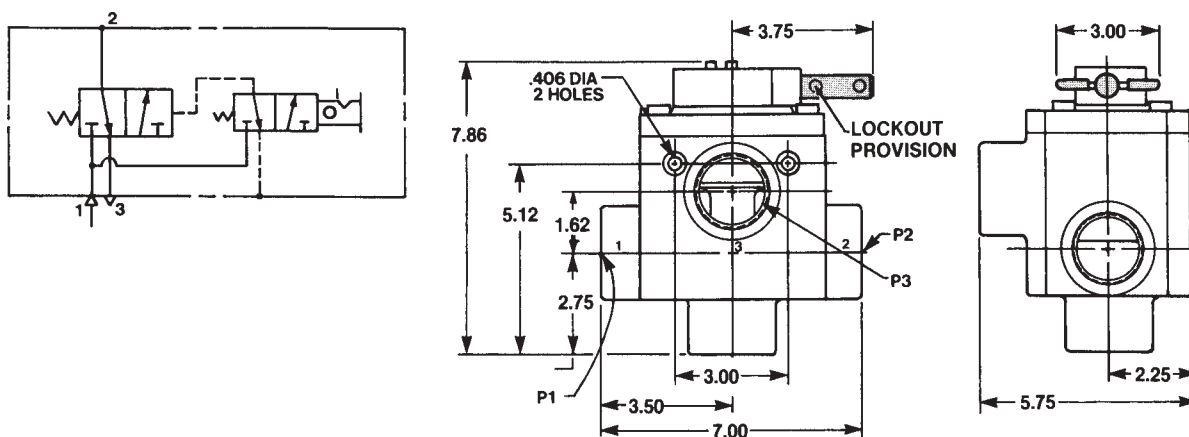

## BIG BAZOOKA LOC-MASTER®

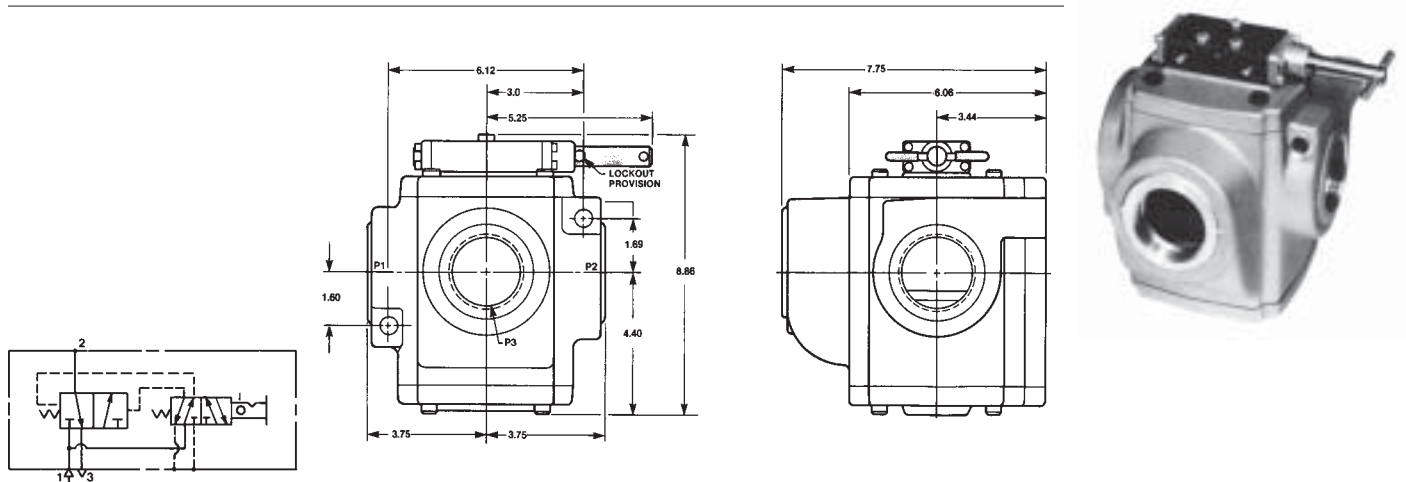

### Specifications

- 30 - 150 psig
- 40 Micron Filtration
- Viton Seals
- 40° to 180° F

| Model No.   | Port Size NPTF |       |       | Cv   | Max. SCFM<br>@80 P.S.I.G. |
|-------------|----------------|-------|-------|------|---------------------------|
|             | 1              | 2     | 3     |      |                           |
| MB045-31-10 | 1              | 1     | 1-1/2 | 24.2 | 1137                      |
| MB045-31-12 | 1-1/4          | 1-1/4 | 1-1/2 | 34.2 | 1612                      |
| MB045-31-15 | 1-1/2          | 1-1/2 | 1-1/2 | 34.2 | 1612                      |
| BB045-31-15 | 1-1/2          | 1-1/2 | 1-1/2 | 44.0 | 2071                      |
| BB045-31-20 | 2              | 2     | 2     | 51.0 | 2397                      |
| BB045-31-25 | 2-1/2          | 2-1/2 | 2-1/2 | 51.0 | 2397                      |



# "ELECTRO-LOC" LOC-MASTER®

The newest lockout valves from Alkon provides a manual lock out feature on 3-way solenoid valves. Both manual and solenoid pilot actuator must be operated for valve to open. Shutting off either manual or solenoid operator causes valve to shift to off position blocking inlet and exhausting downstream air. Manual actuator may be locked off to prevent valve operation.

Available in port sizes 1/2, 3/4, 1, 1-1/4, 1-1/2, 2 and 2-1/2 NPTF.

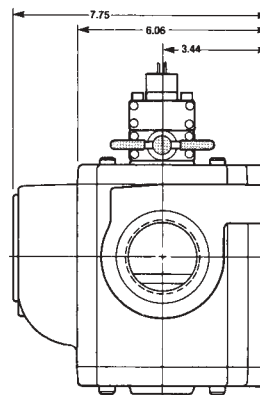
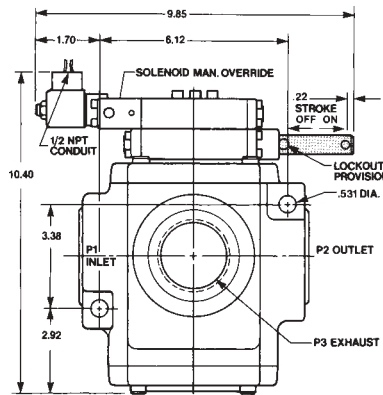
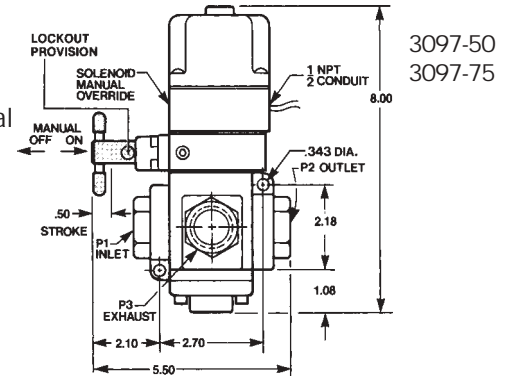
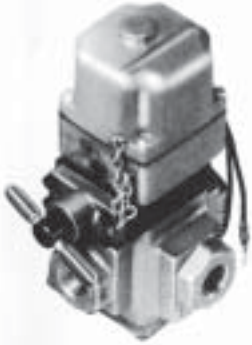

3097-112  
3097-200  
3097-250

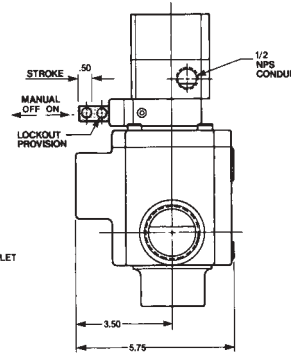
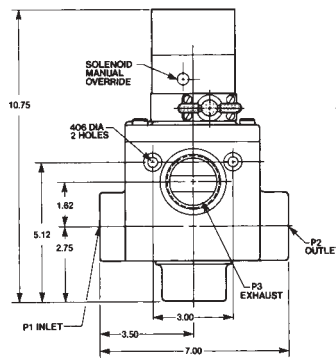
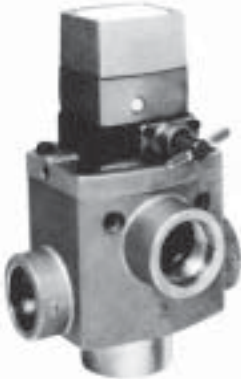

3097-100  
3097-125  
3097-150

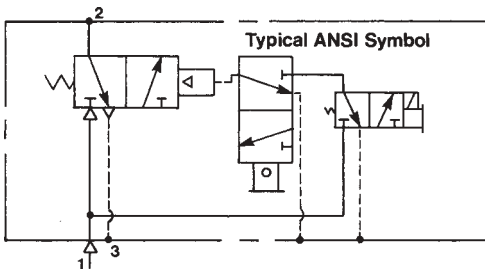

| Model No. | Port Size NPTF |       |       | Cv   | Max. SCFM @80 P.S.I.G. |
|-----------|----------------|-------|-------|------|------------------------|
|           | 1              | 2     | 3     |      |                        |
| 3097-50   | 1/2            | 1/2   | 1/2   | 5.2  | 244                    |
| 3097-75   | 3/4            | 3/4   | 3/4   | 5.7  | 268                    |
| 3097-100  | 1              | 1     | 1-1/2 | 24.2 | 1137                   |
| 3097-125  | 1-1/4          | 1-1/4 | 1-1/2 | 34.2 | 1612                   |
| 3097-150  | 1-1/2          | 1-1/2 | 1-1/2 | 34.2 | 1612                   |
| 3097-112  | 1-1/2          | 1-1/2 | 2-1/2 | 44.0 | 2071                   |
| 3097-200  | 2              | 2     | 2     | 51.0 | 2397                   |
| 3097-250  | 2-1/2          | 2-1/2 | 2-1/2 | 51.0 | 2397                   |

## Specifications

- 30 - 150 psig
- 40 Micron Filtration
- Viton Seals
- 40° to 180° F



# ALKON

## MINI BAZOOKA

MINI BAZOOKA is a 3-Way, 2-Position High Flow Air Valve - designed and built for tough industrial applications. We call it "Mini" because it's a smaller version of the popular industry veteran, the BIG BAZOOKA.



- **HIGH FLOW RATE:** over 34Cv
- **LOW BREAKOUT FRICTION:** Alkon "Thin Lip" Seals virtually eliminate breakout friction insuring rapid response... even at low pressure.
- **VERSATILITY:** Can be piped to provide six different functions. Use MINI BAZOOKA for 2-Way, 3-Way, selector and diverter applications. It can be externally piloted for vacuum or low pressure service. Porting options, operator options, and mounting options make MINI BAZOOKA the most versatile valve of it's type.

## DIMENSIONAL DATA

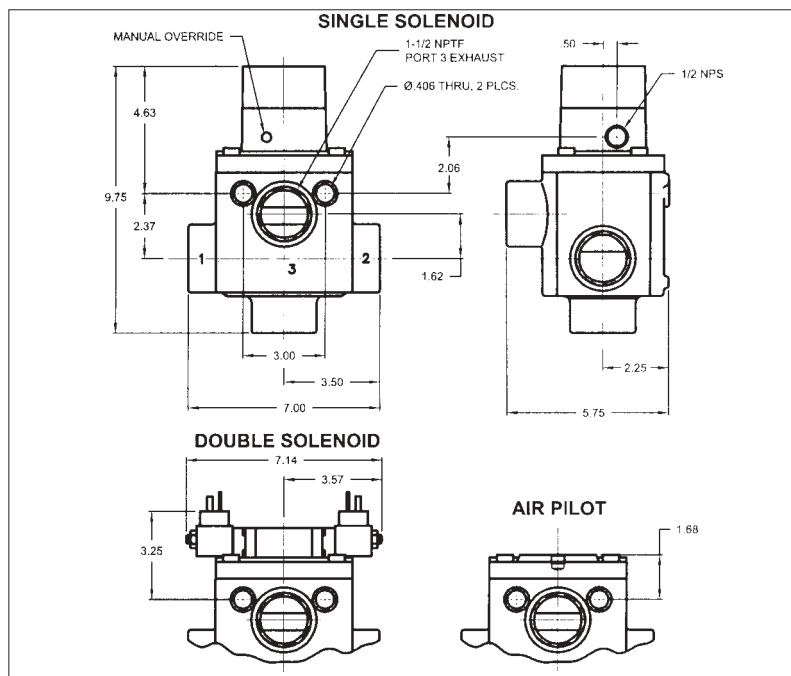

## SOLENOID DATA

|         | 120/60 Hz | 24VDC   |
|---------|-----------|---------|
| IN RUSH | .25 amps  | .5 amps |
| HOLDING | .11 amps  | .5 amps |

## AIR FLOW DATA

| PORT SIZE 1 & 2                | 1 NPTF    |                | 1-1/4 NPTF |                | 1-1/2 NPTF |                |
|--------------------------------|-----------|----------------|------------|----------------|------------|----------------|
|                                | IN TO OUT | OUT TO EXHAUST | IN TO OUT  | OUT TO EXHAUST | IN TO OUT  | OUT TO EXHAUST |
| <b>NORMALLY CLOSED</b>         |           |                |            |                |            |                |
| <b>Cv</b>                      | 24.2      | 24.2           | 34.3       | 33.0           | 34.3       | 33.0           |
| <b>MAX FLOW SCFM @ 80 PSIG</b> | 1139      | 1139           | 1610       | 1549           | 1610       | 1549           |

## REPAIR PARTS

| SOLENOID PILOT                              |          | VALVE BODY             |                  |                  |
|---|----------|------------------------|------------------|------------------|
| Complete Solenoid Pilot Assy. - Non Locking | 91A20085 | Spool Assy. with Seals | N.C.<br>90A20158 | N.O.<br>90A20159 |
| Solenoid Assy.                              | 09A01033 | O'Rings                | 08A01064         | 08A01074         |
| Coil  | 26A01000 | Spring                 | 07A01077         |                  |



# MINI BAZOOKA ORDERING INFORMATION

## EXAMPLE

**MB 331 - 31 - 12 - L - 1**

### PILOT VALVE OPERATORS

- SINGLE SOLENOID with non-locking manual override spring return..... 331
- DOUBLE SOLENOID (Momentary Contact)..... 332
- AIR PILOT spring return (Momentary Contact)..... 031
- DOUBLE AIR PILOT (Momentary Contact)..... 032
- LOC-MASTER safety Bleed Valve ..... 045

\*Non Locking Manual Override Standard on Solenoid Valves

### MAIN VALVE OPTIONS

- 2-WAY - Normally Closed (3 Port Plugged)..... 21
- 2-WAY - Normally Open (3 Port Plugged)..... 22
- 3-WAY - Normally Closed..... 31
- 3-WAY - Normally Open..... 32
- See Piping Instructions - Shown Below

### PORT SIZE DESIGNATION

- 1 NPTF..... 10
- 1-1/4 NPTF..... 12
- 1-1/2 NPTF..... 15

### OPTIONAL

Locking Manual Override..... L

Voltages & Cycles..... specify

- Standard Voltages
- 1= 120/60
- 2= 12VDC
- 3= 24/60
- 4= 240/60
- 5= 24VDC
- 6= 120VDC

## MAIN VALVE BODY DATA

### ANSI SYMBOLS

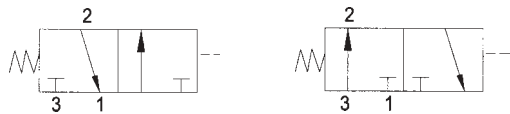

3 Way N.C.

3 Way N.O.

- Valve may be mounted in any position
- Dynamic Seals..... Viton
- Maximum Operating Pressure..... 125 psig
- Minimum Operating Pressure..... 30 psig
- Media..... Air only
- External Pilot Available for Low Pressure/Vacuum Applications (specify)
- Shipping Weight Approx. 12 lbs.

### PIPING ARRANGEMENTS

| APPLICATION                             | PORT #1 | PORT #2 | PORT #3 |
|---|---------|---------|---------|
| 3-Way Normally Closed                   | Supply  | Outlet  | Exhaust |
| 3-Way Normally Open                     | Supply  | Outlet  | Exhaust |
| 2-Way Normally Closed                   | Supply  | Outlet  | Plugged |
| 2-Way Normally Open                     | Supply  | Outlet  | Plugged |
| LOC-MASTER 3-Way Normally Closed - Only | Supply  | Outlet  | Exhaust |



# ALKON

## BIG BAZOOKA

BIG BAZOOKA with a Cv of 45 offers a large enough flow rating to safely control a complete industrial air system. For example: In solenoid operation, it could be held in an energized position, feeding air to a complete automation system. Should the system's main disconnect be moved to the off position, BIG BAZOOKA shuts off and bleeds the complete system. BIG BAZOOKA is also available manually operated with safety lock or air pilot operated.



### MAIN VALVE 2 or 3 Way Function

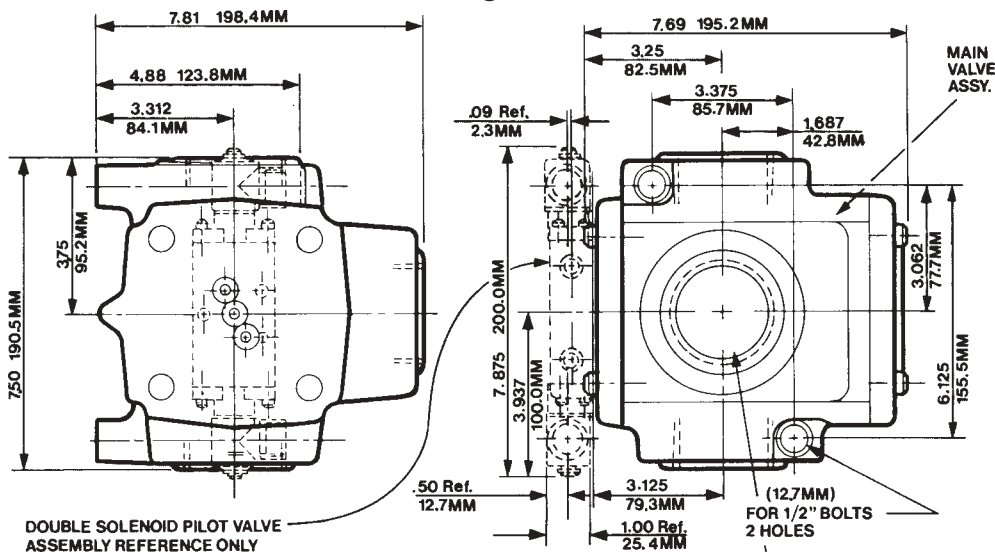

**CAUTION!!**  
Air exhaust of this capacity can be dangerous. Installation of an Alkon silencer will protect personnel and keep the exhaust sound level within OSHA standards.

### Compare These Alkon Features...

Full ported and rated. Basic minimum orifice; 2.06 inches.

Versatile - can be piped for 6 different applications.

Closed crossover design prevents crossbleeding and allows complete versatility in piping.

Pilot valve design allows complete design & application freedom.

Unique orifice arrangement provides extremely compact design with maximum flow.

### Solenoid Operated

The solenoid pilot valve operator provides remote electrical operation of the main valve assembly.

- SINGLE MAINTAINED CONTACT
- DOUBLE MOMENTARY CONTACT

#### ANSI SYMBOLS

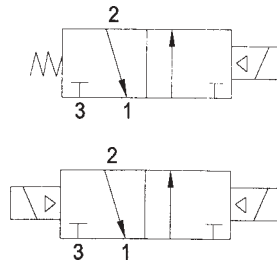

"Thin Lip" spool seal design provides negligible breakout friction and fast response.

Solenoid models: Solenoid pilot assembly.

Can be line or foot mounted in any position.

External pilot can be supplied for low pressure and vacuum applications.

### Pilot Operated

The air operated pilot valve provides remote operation of the main valve assembly without any electrical interface, from any manual, mechanical or remote valve pilot signal.

- SINGLE MAINTAINED CONTACT
- DOUBLE MOMENTARY CONTACT

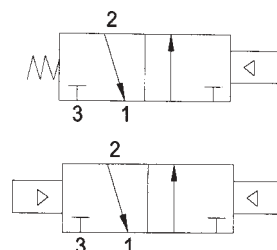



# BIG BAZOOKA ORDERING INFORMATION

## EXAMPLE

**BB 331 - 301 - 20 - 2 - 120V / 60Hz**

### PILOT VALVE OPERATORS

- SINGLE SOLENOID  
spring return  
maintained contact..... 331
- DOUBLE SOLENOID  
(Momentary Contact)..... 332
- AIR PILOT  
spring return  
(Maintained Contact)..... 031
- DOUBLE AIR PILOT  
(Momentary Contact)..... 032
- LOC-MASTER Safety  
Bleed Valve ..... 045
- SINGLE SOLENOID  
Explosion Proof  
(Maintained Contact)..... 421
- DOUBLE SOLENOID  
Explosion Proof  
(Momentary Contact)..... 422

### MAIN VALVE OPTIONS

- 2-WAY - Normally Closed  
(3 Port Plugged)..... 20
- 2-WAY - Normally Open  
(3 Port Plugged)..... 21
- 3-WAY - Normally Closed..... 31
- 3-WAY - Normally Open..... 32
- 3-WAY - Selector Valve..... 33
- 3-WAY - Directional Valve..... 34

See Piping Instructions

### MAIN VALVE

- Minimum Orifice.... 2.06 inches
- Valve may be mounted in any position
- Maximum Operating Pressure..... 125 psig
- Minimum Operating Pressure..... 30 psig
- Media..... Air only
- External Pilot Available for Low Pressure/Vacuum Applications (specify)

### SOLENOID DATA

Pilot Operated coils with self compensating plungers. Solenoid Assembly guaranteed for life of valve.

P.S.I.G

Cv = 45

70 - 2150 S.C.F.M.

|                 |               |
|-----------------|---------------|
|                 | <b>120/60</b> |
| Inrush Current  | .11 amps      |
| Holding Current | .068 amps     |

### PORT SIZE DESIGNATION

- 1-1/2 NPTF..... 15
- 2 NPTF..... 20
- 2-1/2 NPTF..... 25

### ACCESSORIES & OPTIONS

- MANUAL OVERRIDE-  
Non Locking-  
Solenoid Models Only..... 1
- Manual Override-  
Locking Type..... 2

External Pilot (for Vacuum & Low Pressure applications)..... specify  
Voltage & Cycles..... specify

- |          |           |           |
|----------|-----------|-----------|
| Standard | 1= 120/60 | 4= 240/60 |
| Voltages | 2= 12VDC  | 5= 24VDC  |
|          | 3= 24/60  | 6= 120VDC |

Other voltages & explosion proof models available.

### PIPING ARRANGEMENTS

| APPLICATION                                    | PORT #1       | PORT #2 | PORT #3     |
|--|---------------|---------|-------------|
| 3-Way Normally Closed                          | Supply        | Outlet  | Exhaust     |
| 3-Way Normally Open                            | Supply        | Outlet  | Exhaust     |
| 2-Way Normally Closed                          | Supply        | Outlet  | Plugged     |
| 2-Way Normally Open                            | Supply        | Outlet  | Plugged     |
| Directional Valve<br>(requires external pilot) | Closed Outlet | Supply  | Open Outlet |
| Selector Valve<br>(requires external pilot)    | Supply        | Outlet  | Supply      |
| Loc-Master                                     | Supply        | Outlet  | Exhaust     |



# ALKON

## AUTOMOTIVE INDY SERIES VALVES

---

### THE ULTIMATE in HIGH PERFORMANCE

With a solid state circuit board, air-assisted return, sturdy seals, and an innovative tri-power system, Alkon's Indy Series delivers consistent, reliable performance - even in the most hostile environments. Indy's non-locking manual override allows for tooling setup and exceptional cyclability. Solid state technology has replaced all internal wiring with a printed circuit board design. It incorporates a built-in surge suppressor, a plug-in solenoid, solid state LED, and is PLC compatible.

Alkon's air relay technology maximizes valve speed while simultaneously reducing power consumption. Our patented "thin lip" seals are fabricated from PTFE-loaded Viton. This combined with Indy's innovated end seals provide a dirt-tolerant, positive air tight seal assuring the user millions of cycles of highly reliable operation.

---

### FEATURES

**Tri-Powered:** The Indy incorporates a low watt solenoid pilot valve, Alkon's air relay technology and an air assisted spring return to virtually guarantee valve function - every time.

**Maximum Flow:** The Indy series of air valves have the highest flow ratings in the industry.

**Speedy "Pits" and Changeovers:** Spool replacement is easy- just remove the end cap and slide in a new pre-lubed spool.

**Fast Response:** Air-assisted return, air relay technology, and the tri-power system guarantee fast valve response on every cycle.

**Low Maintenance:** The solid state circuit board and easy-to-replace spool substantially reduce the need for maintenance on the Indy series.

**Low Power Consumption:** The Indy's air pilot solenoid, low watt coil, and built-in air relay technology provide maximum performance with a minimum of power.

**Multiple Voltage Options:** You will always have the right valve on your team with this Indy feature. One valve, one connector for 24VDC to 120VDC and 48VAC to 120VAC.

**Wiring Options:** Other pin combinations are available in addition to automotive versions.

**Reduced-Wear Components:** A wear-resistant thin lip piston along with the Indy's rugged end seals help to ensure that the Indy is a dependable, long lasting air valve system.

**Warranty:** 5-years for defects in material (including solenoids) and workmanship; soft seals warranted for 18 months as normal wear parts.

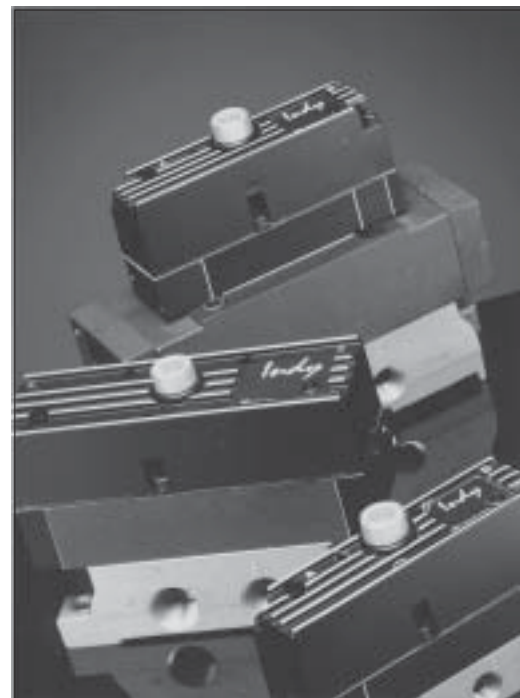

## AUTOMOTIVE INDY SERIES VALVES

Alkon has set the pace with the "Indy" AU Series - an innovation in air valve technology. The Indy Series runs faster with higher flow volumes, requires fewer maintenance stops, and performs in almost any environment with endurance of millions of cycles.

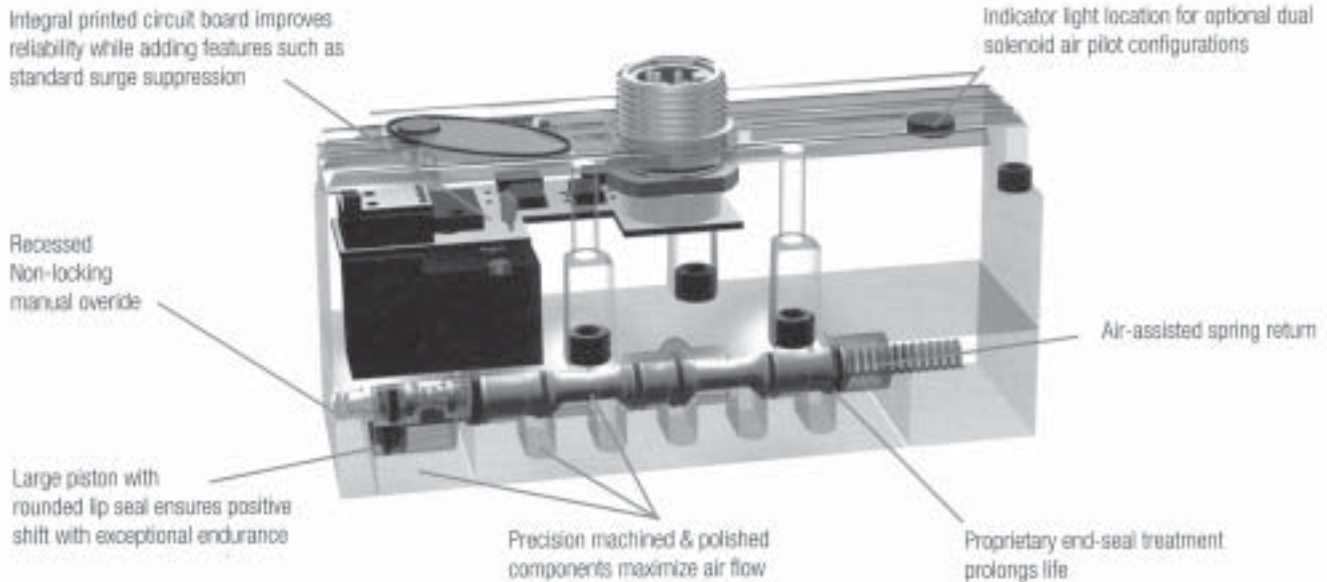
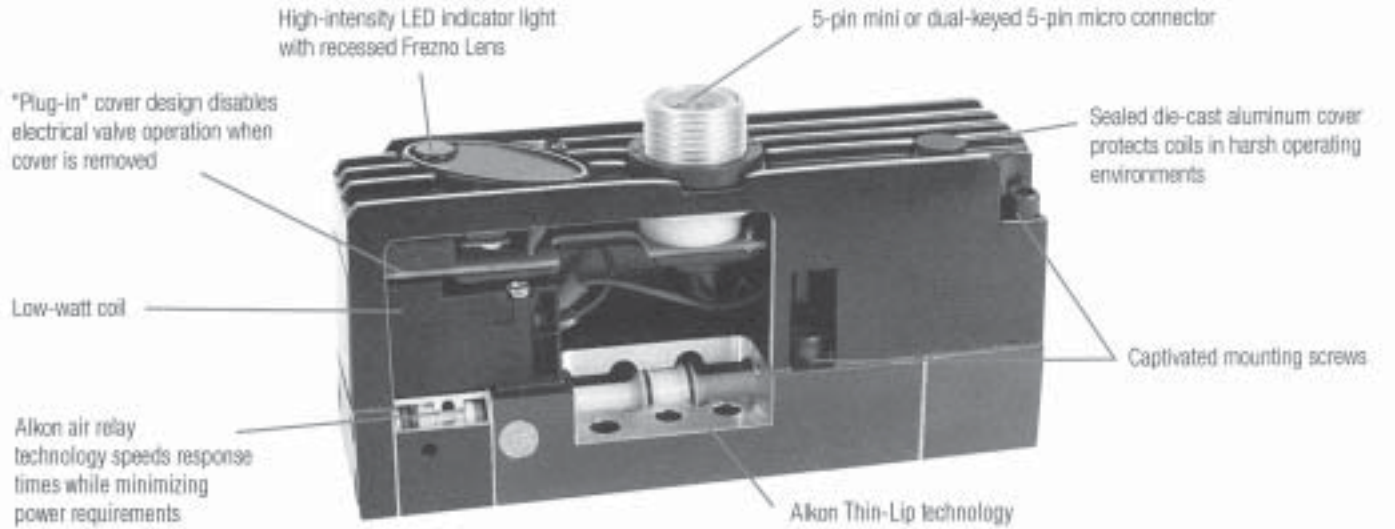



# ALKON

## INDY AU-1

### Solenoid Operated

#### FEATURES:

- Port Sizes: 1/8", 1/4", 3/8", 1/2"
- Exceeds Automotive Response Standards by 300%
- AC or DC
- Standard voltage options
- Dual rated for 50/60 cycles
- Epoxy molded coils equal or exceed UL and CSA standards
- Indicator lights standard
- Manual override
- For lubed or non-lubed service
- Automotive interface
- Air-pilot operated models available
- Multiple voltage option

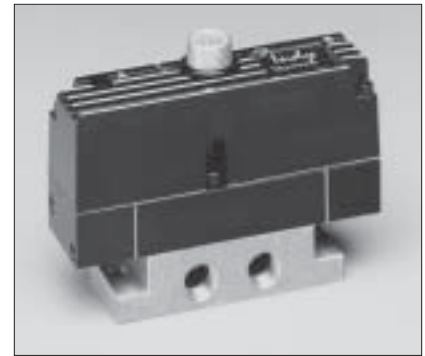

#### AIR FLOW DATA

| Port Size | Avg. Cv. | SCFM @ 80 psi |
|-----------|----------|---------------|
| 1/8 NPT   | 1.4      | 66            |
| 1/4 NPT   | 2.1      | 99            |
| 3/8 NPT   | 2.4      | 113           |
| 1/2 NPT   | 3.1      | 147           |

#### Weight (pounds)

|                    |      |
|--------------------|------|
| Single solenoid    | 1.6  |
| Double solenoid    | 1.7  |
| Base               | .614 |
| Manifold           | 1.16 |
| End Plate Assembly | 1.14 |

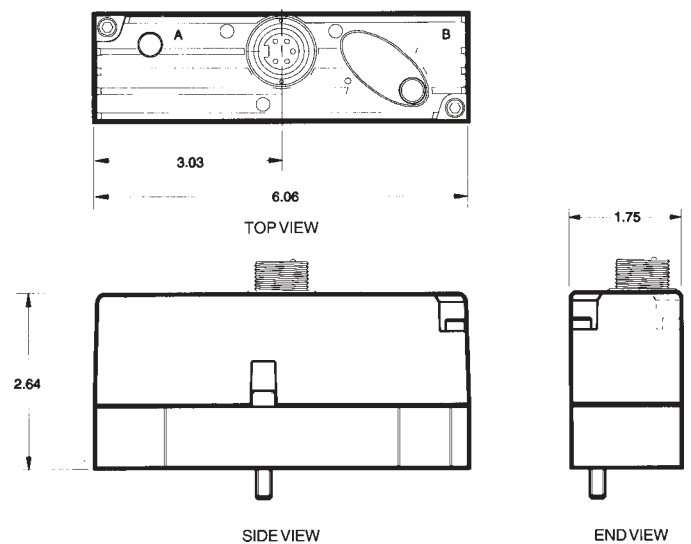

#### End Plate Assembly

|        |                            |
|--------|----------------------------|
| AU1-25 | 1/4 NPT End Plate Assembly |
| AU1-37 | 3/8 NPT End Plate Assembly |
| AU1-50 | 1/2 NPT End Plate Assembly |

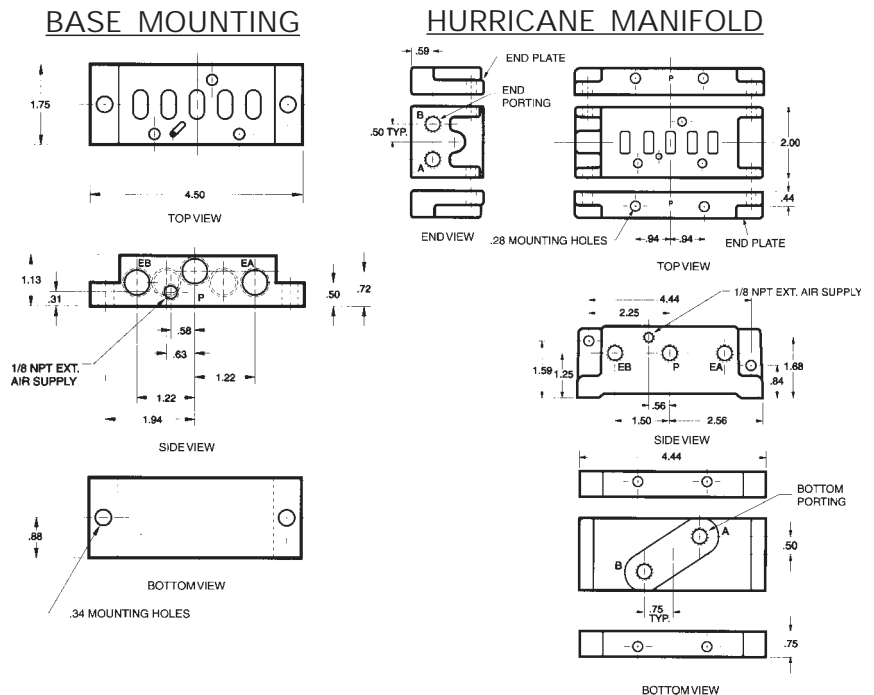

Note: Transition Plate between manifolds to combine AU1 and AU2 manifolds: see ordering information.

Note: For 1/2" ported base and manifold dimensional information: consult factory.



# INDY AU-2

## Solenoid Operated

### FEATURES:

- Port Sizes: 1/8", 1/4", 3/8", 1/2"
- Exceeds Automotive Response Standards by 300%
- AC or DC
- Standard voltage options
- Dual rated for 50/60 cycles
- Epoxy molded coils equal or exceed UL and CSA standards
- Indicator lights standard
- Manual override
- For lubed or non-lubed service
- Automotive interface
- Air-pilot operated models available
- Multiple voltage option

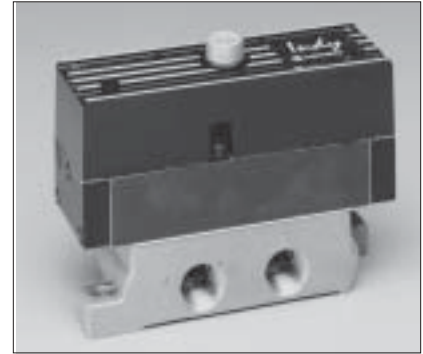

### AIR FLOW DATA

| Port Size | Avg. Cv. | SCFM @ 80 psi |
|-----------|----------|---------------|
| 1/4 NPT   | 2.8      | 132           |
| 3/8 NPT   | 4.9      | 231           |
| 1/2 NPT   | 6.1      | 287           |
| 3/4 NPT   | 6.6      | 310           |

### Weight (pounds)

|                 |      |
|-----------------|------|
| Single solenoid | 4.02 |
| Double solenoid | 4.21 |
| Base            | 1.78 |
| Manifold        | 2.12 |

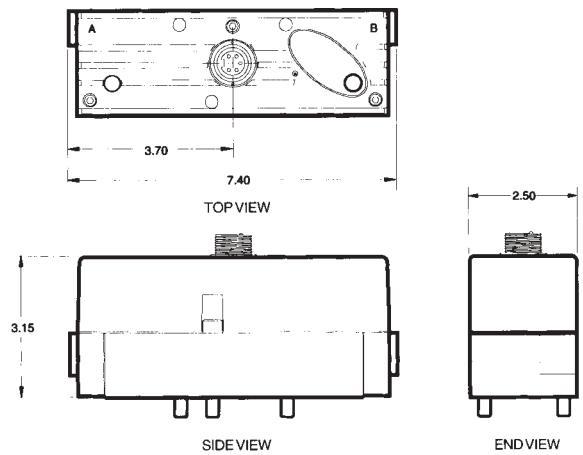

### BASE MOUNTING

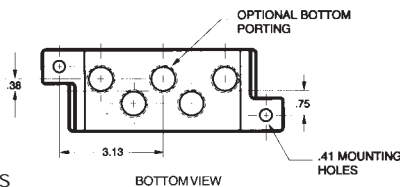
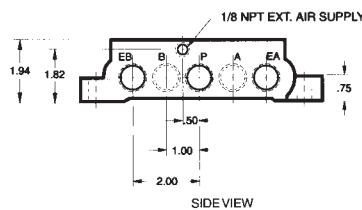
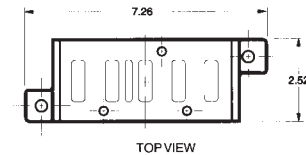

### HURRICANE MANIFOLD

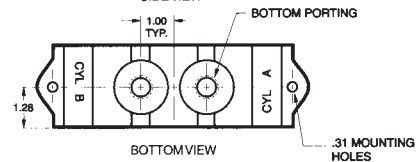
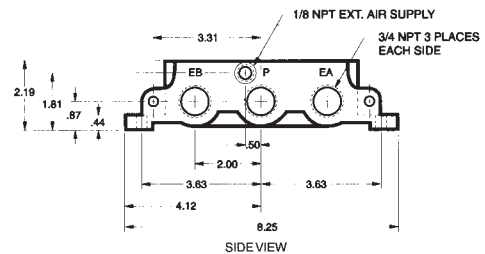
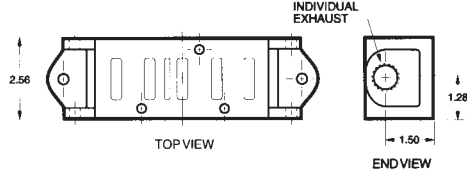

Note: Transition Plate between manifolds to combine AU1 and AU2 manifolds or AU2 and AU5 manifolds: see ordering information.



# ALKON

## INDY AU-5

### Solenoid Operated

#### FEATURES:

- Port Sizes: 1/2", 3/4", 1"
- AC or DC
- Standard voltage options
- Dual rated for 50/60 cycles
- Epoxy molded coils equal or exceed UL and CSA standards
- Indicator lights standard
- Manual override
- For lubed or non-lubed service
- Automotive interface
- Air-pilot operated models available
- Multiple voltage option

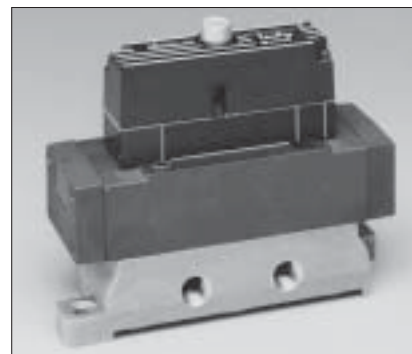

#### AIR FLOW DATA

| Port Size | Avg. Cv. | SCFM @ 80 psi |
|-----------|----------|---------------|
| 1/2 NPT   | 8.6      | 404           |
| 3/4 NPT   | 11.1     | 522           |
| 1 NPT     | 12.5     | 588           |

#### Weight (pounds)

|                 |      |
|-----------------|------|
| Single solenoid | 5.18 |
| Double solenoid | 5.47 |
| Base            | 3.03 |
| Manifold        | 2.34 |

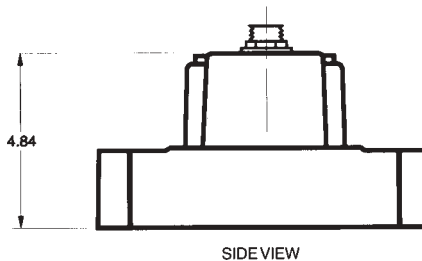
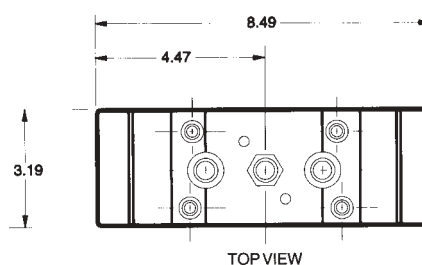

#### BASE MOUNTING

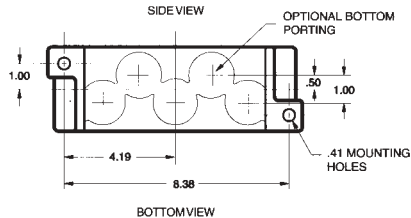
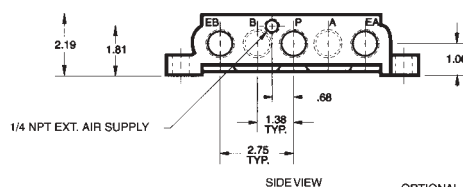
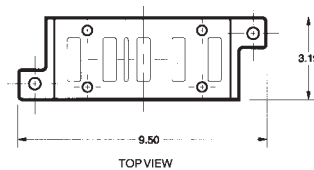

#### HURRICANE MANIFOLD

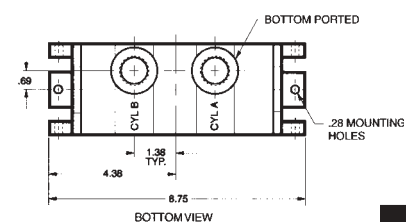
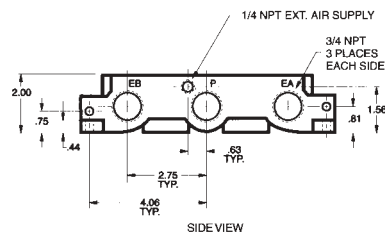
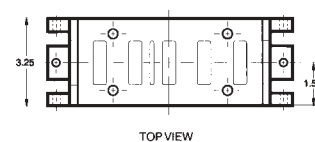

Note: Transition Plate between manifolds to combine AU2 and AU5 manifolds: see ordering information.



# S.O.S. CYLINDER CONTROL

The SOS bypass valve is an interface between an automotive 250 size valve (AU-2) and base. The SOS valve works in conjunction with the 4-way 3-position ("B" spool) power valve to provide 3-position valve function plus the ability to render the valve and cylinder combination safe for maintenance.

The 3-position power valve enables the operator to stop cylinder movement by de-energizing both solenoids on the power valve, causing the spool to center, thus blocking all valve ports. This function is useful during emergency stop procedures.

By bleeding the trapped air between the valve and the cylinder piston (both sides), the SOS bypass valve renders the "charged" air cylinder safe. This function is initiated by exhausting supply pressure to the power valve.

The bypass valve also allows both sides of the cylinder to "precharge" simultaneously when supply pressure is reapplied to the power valve. After the cylinder is filled with equal pressure on both piston sides, the bypass valve disables, and the power valve takes command. This cylinder precharging method allows the flow controls to properly operate on the first cycle to prevent cylinder slamming.

## FEATURES:

- Compact modular construction
- Safely neutralizes pneumatic cylinder movement if emergency stop is initiated
- Exhausts cylinder air when supply pressure is exhausted
- "Pre-charges" system when air is applied to prevent cylinder slamming
- Bypassed to normal 4-way valve operation when system is not being exhausted or pressurized
- Single or dual interposed regulation available
- Automotive interface

## AIR FLOW DATA:

| Model | Port Size | Average Cv |
|-------|-----------|------------|
| AU-2  | 1/2 NPT   | 4.0        |
| AU-2  | 3/4 NPT   | 4.4        |

## ORDERING INFORMATION:

Horizontal Cylinder Applications

To order an S.O.S. Control Valve; select the following:

1. Model Number
2. Pipe Size
3. Operator Style
4. Voltage/Hertz

## EXAMPLE:

**AU2 - 10007 - 37F - 120V**

Voltage:  
Specify 120V AC or 24 VDC

Operator:

- 37F - Solenoid w/ 5 Pin Mini Connector (Ford Wired)
- 37C - Solenoid w/ 5 Pin Mini Connector (Chrysler Wired)
- 57F - Solenoid w/ 5 Pin Micro Connector (Ford Wired)
- 57C - Solenoid w/ 5 Pin Micro Connector (Chrysler Wired)
- 03 - Air Pilot Operated

Model/Pipe Size:

- 10007 = 1/2 NPT
- 10008 = 3/4 NPT
- 10009 = Valve Assembly Less Base

Series

NOTE: Vertical Cylinder Applications,  
Add AU2-AMR-O Regulator and 90A50125 Kit.

HORIZONTAL CYLINDER OPERATION

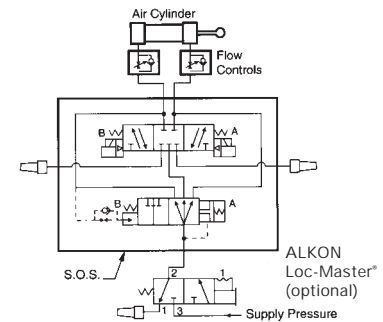

VERTICAL CYLINDER OPERATION

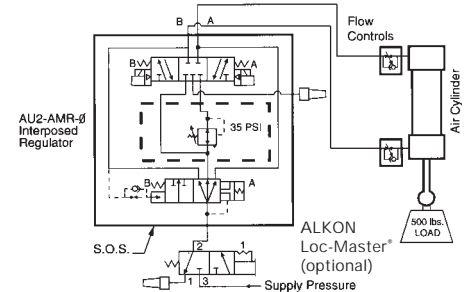



# ALKON

## INTERPOSED REGULATORS for AU-1 & AU-2

Patented\* AU Series Full Flow Regulators provide quick response and precise control. By regulating the pressure through the valve, Alkon's regulators give you maximum efficiency without a decrease in air flow. The "sandwich" type regulator is available for the AU-1 & 2 models, with single or dual pressure regulation.

AU Series Full Flow Regulators are for use with lubed or non-lubed, standard 40 micron filtered air.

\* U.S. Patent #5,327,926

### FEATURES:

- Full Flow: Valve system shows no drop in flow when this regulator is added
- Single or dual regulation
- Modular construction allows easy maintenance
- Automotive interface

### TECHNICAL DATA:

- AU-1: 100 SCFM @ 80 psi
- AU-2: 223 SCFM @ 80 psi
- Single or dual regulation
- Control Range: 0 - 100 psi
- Maximum Supply Pressure: 150 psi
- Supply Pressure: 10 psig greater than outlet pressure
- Temperature Range: 0° to 180° F
- Materials: Aluminum with stainless components
- Control Knob: Nylon
- Bonded Seals: Buna-N
- Seals: Teflon-coated Viton

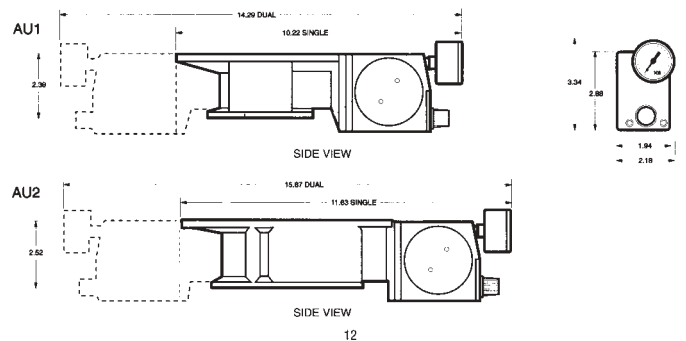
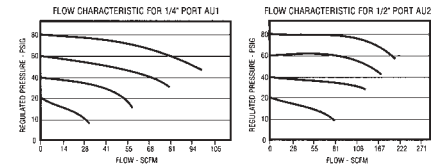

### HOW TO ORDER

#### EXAMPLE:

AU2 - SMR - 0

Options:  
0 None  
1 Tamperproof

Regulator Type:  
SMR Single/Manual  
DMR Dual/Manual  
AMR Single/Manual A Port Regulated  
BMR Single/Manual B Port Regulated

Series  
Automation 125 AU1  
Automation 250 AU2

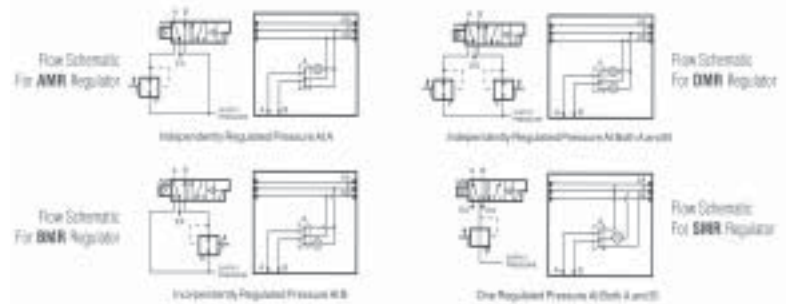
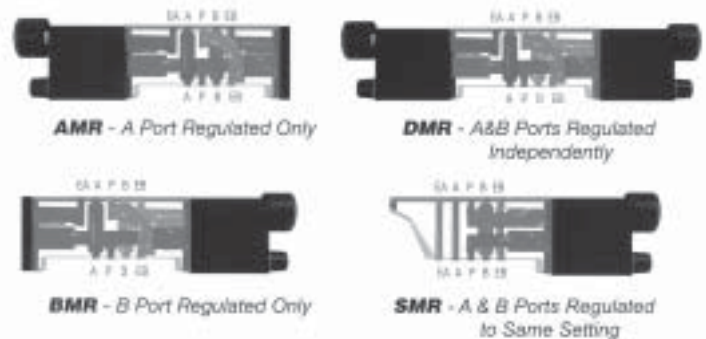

#### Weight (pounds)

|     |          |      |
|-----|----------|------|
| AU1 | SMR      | 2.71 |
| AU1 | AMR, BMR | 3.44 |
| AU1 | DMR      | 4.12 |
| AU2 | SMR      | 3.57 |
| AU2 | AMR, BMR | 4.23 |
| AU2 | DMR      | 5.16 |

### INDY AU SERIES OPERATING SPECIFICATIONS

- Media: Air and inert gasses
- Filtration: 40 microns
- Pressure Range:
  - Pilot Air - Maximum 30 psig to 150 psig and not less than main air supply. Vacuum to 30 psig available.
  - Main Supply - 30 to 150 psig (standard)
- Temperature: 0° to 180° F
- Flow Capacity: 1.4 to 12.5 Cv
- Lubrication: All valves are prelubricated and will operate with dry air (no additional lubrication required) However, a lubricated system will greatly extend the service life of any valve

### ELECTRICAL:

#### AU-1 & AU-2 Electrical Characteristics

| Standard Voltage | Inrush Current | Holding Current | Power      |
|------------------|----------------|-----------------|------------|
| 120 VAC 50/60 Hz | 60mA           | 50mA            | 6 watts    |
| 24 VDC           | 60mA           | 60mA            | 1.44 watts |

#### AU-1 & AU-2 Multiple Voltage Electrical Characteristics

| Standard Voltage      | Inrush Current | Holding Current | Power                 |
|-----------------------|----------------|-----------------|-----------------------|
| 24 - 120 VDC          | 55mA ±10%      | 50mA ±10%       | Actual Voltage x .055 |
| 48 - 120 VAC 50/60 Hz | 125mA ±25%     | 50mA ±10%       | Actual Voltage x .055 |

#### AU-5 Electrical Characteristics

| Standard Voltage | Inrush Current | Holding Current | Power     |
|------------------|----------------|-----------------|-----------|
| 110 VAC 50/60 Hz | 130mA          | 80mA            | 8.8 watts |
| 120 VAC 50/60 Hz | 110mA          | 70mA            | 8.4 watts |
| 240 VAC 50/60 Hz | 60mA           | 30mA            | 7.2 watts |
| 24 VDC           | 290mA          | 290mA           | 6.9 watts |

120/60 Hz can be connected to 110/50 Hz.  
 Encapsulated coils are standard.  
 All solenoids are designed to meet or exceed UL and CSA standards.  
 Coils are rated for continuous duty.

### ANSI Symbols

#### 2 Position "O" Spool



#### 3 Position "B" Spool



#### 3 Position "P" Spool



#### 3 Position "E" Spool

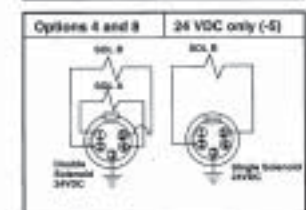
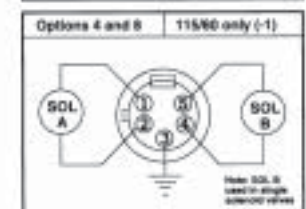
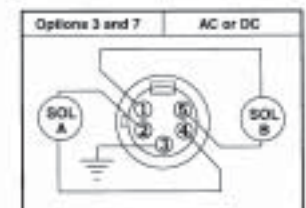

### Cv Conversion to S.C.F.M.

| Cv | P.S.I.G. | S.C.F.M. |
|----|----------|----------|
| 1  | 40       | 27       |
| 1  | 50       | 32       |
| 1  | 60       | 37       |
| 1  | 70       | 42       |
| 1  | 80       | 47       |
| 1  | 90       | 52       |
| 1  | 100      | 57       |



## INDY ORDERING INFORMATION

### Indy AU Series Valves (Automotive Common Interface)

#### Valve Assembly Designation

(Does not include base)

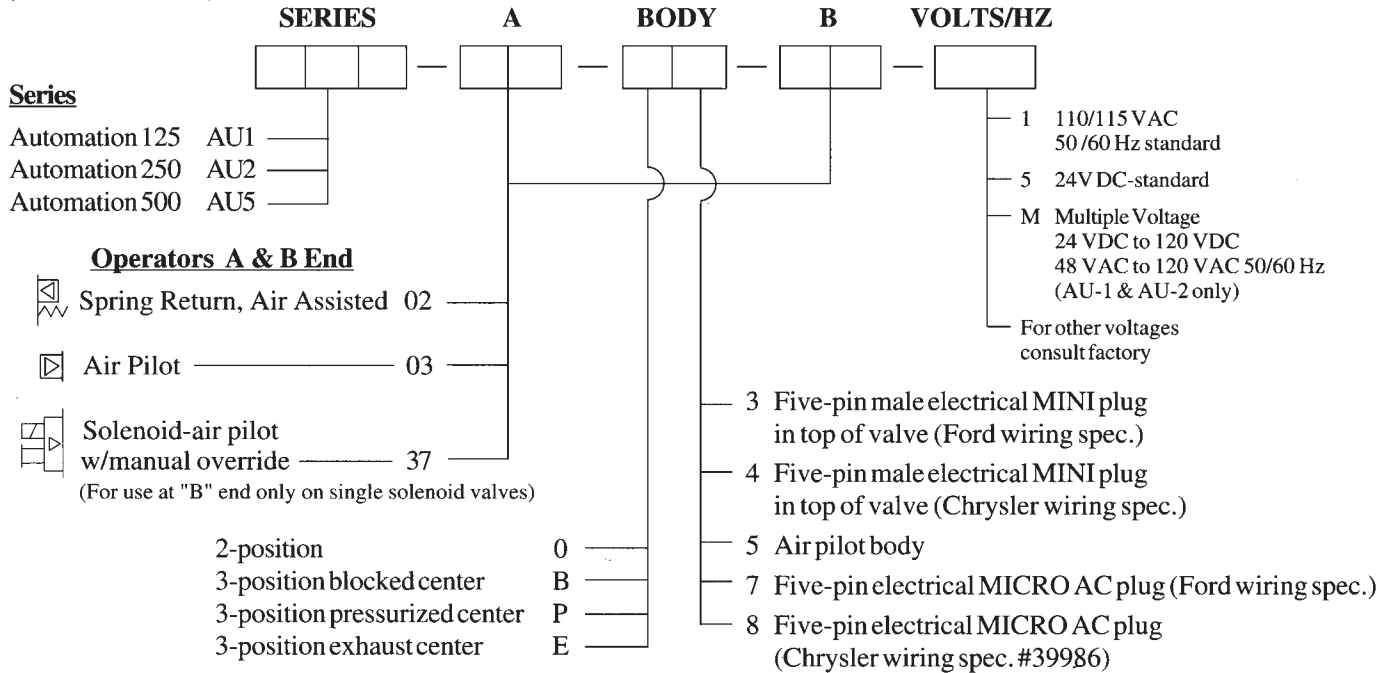

#### Base/Manifold Assembly Designation

(Does not include valve)

#### Series

- Automation 125 AU1
- Automation 250 AU2
- Automation 500 AU5

Notes: \*AU1 (only) requires End Plate Assembly  
 \*\*3/4" NPT port not available on AU2 base

#### Base

- Standard base 1
- \*Manifold base 2
- Blank station base 3

#### Port Size

- 1/8" NPT 1
- 1/4" NPT 2
- 3/8" NPT 3
- 1/2" NPT 4
- 3/4" NPT 5
- 1" NPT 6

**Transition Plates:** Manifold  
 Use to combine AU valves of two different sizes in one manifold combination.  
 AU1+2 combines AU1 & AU2 valves.  
 AU2+5 combines AU2 & AU5 valves.

- 0 Side ports (base)
- 1 Bottom ports (base) AU2\*\* & AU5 only
- 2 Bottom-ported manifold (w/common exhaust)
- 3 Bottom-ported manifold (w/individual exhaust) AU2 & AU5 only
- 4 End-ported manifold (w/common exhaust) AU1 only

### Replacement Parts

| REPLACEMENT SPOOL (includes seals) | AU-1     | AU-2     | AU-5     |
|------------------------------------|----------|----------|----------|
| Option "O" Spool                   | 90A20335 | 90A20341 | 90A20260 |
| Option "B" Spool                   | 90A20336 | 90A20345 | 90A20292 |
| Option "E" Spool                   | 90A20337 | 90A20346 | 90A20294 |
| Option "P" Spool                   | 90A20338 | 90A20347 | 90A20293 |

| REPLACEMENT SOLENOID ASSEMBLIES | AU-1 & 2 | AU-5            |
|---------------------------------|----------|-----------------|
| Voltage "1"                     | 91A30167 | Consult Factory |
| Voltage "5"                     | 91A30168 | Consult Factory |

When ordering parts, please include complete valve number.



# PROPORTIONAL CONTROL VALVES

## PV1 PROPORTIONAL VALVE

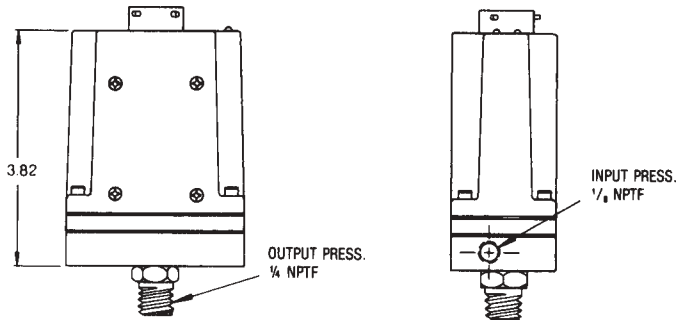
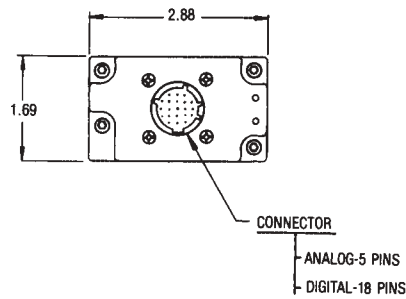

Designed for industrial applications, the PV 1 delivers precise proportional control of pneumatic output by reading analog or digital input command signals generated by a programmable controller or other remote power device. Response is instantaneous, precise and repeatable, relative to input command voltage.

PV1 is activated by connection to a 15-24 VDC power supply. You can use either analog or digital input signals to direct the PV1 to produce a proportional pneumatic output. This versatility in the module allows the use of a variety of controllers and other power devices for input signals.

PV1 contains two external feedback features. The first is a 0-10 VDC linear output from a self-contained pressure sensor that monitors pressure at the output port. The second, a TTL (transistor-to-transistor logic) output, informs you that the PV1 has achieved the desired command pressure. Also provided is an indicator light on the unit visually signaling that command pressure has been achieved.

### GENERAL ENGINEERING DATA

- **Media:** Air or neutral gases.
- **Recommended Filtration:** 40 Micron.
- **Lubrication:** Can be used in non-lubed systems or with standard lubricated lines.
- **Versatility:** Can be mounted to any standard air pilot-operated regulator or the specifically-designed Alkon pilot operated regulator. 1/4 NPT male thread standard.
- **Modular Construction:** Factory adjustable and repairable.

### ELECTRICAL CONNECTION

- Alkon #39A01133 (Analog)
  - Alkon #39A01134 (Digital) or equivalents
- See page 80 for Connector Pinout Information.

### PERFORMANCE SPECIFICATIONS

| Pneumatic                       | Min. | Typ. | Max. | Units                        |
|---------------------------------|------|------|------|------------------------------|
| Regulated Output Pressure       | 0    |      | 100  | psi                          |
| Input Pressure                  | 8    |      | 125  | psi                          |
| Temperature                     | 0    |      | 60   | °C                           |
| Combined Linearity & Hysteresis |      | .5   | 1.2  | ±% Range                     |
| Repeatability                   |      | .4   | 1.2  | ±% Range                     |
| Sensitivity                     |      | .4   | 1.2  | psi                          |
| Resolution                      |      | .4   | 1.2  | psi                          |
| *Flow .030 Orifice              |      | .016 |      | C <sub>v</sub>               |
| Response Time 0 to 100 psi      |      | 15   | 25   | ms (10%-90% of supply ports) |
| Volume size = 1 in <sup>3</sup> |      |      |      |                              |
| Response Time 0 to 100 psi      |      |      | 30   | ms (90%-10% of supply ports) |
| Volume size = 1 in <sup>3</sup> |      |      |      |                              |

\*Note: Response times are dependant on volume size and supply pressure

| Electrical                                  | Min. | Typ. | Max. | Units    |
|---|------|------|------|----------|
| Supply Voltage                              | 15   | 18   | 24   | Volts DC |
| Current Draw                                |      |      | 300  | mA       |
| Analog Feedback                             | .05  |      | 10   | Volts    |
| Input: Analog Model                         | 0    |      | 10   | Volts    |
| Input: Digital Model 8-Bit                  |      |      |      |          |
| Parallel                                    |      |      |      |          |
| Logic Low                                   | 0    |      | 1.0  | Volts    |
| Logic High                                  | 3.5  |      | 15   | Volts    |
| Status Indicators                           |      |      |      |          |
| Red, Power on LED                           |      |      |      |          |
| Green, pressure achieved LED                |      |      |      |          |
| Hysteresis                                  |      | ±3   |      | psi      |
| TTL open collector pressure-achieved output |      |      |      |          |
| Hysteresis                                  |      | ±3   |      | psi      |
| Sink Current                                |      |      | 20   | mA       |
| Voltage                                     |      |      | 20   | Volts DC |



# ALKON

## PROPORTIONAL CONTROL VALVES

### “MASTER FLOW” PROPORTIONAL IN-LINE REGULATOR

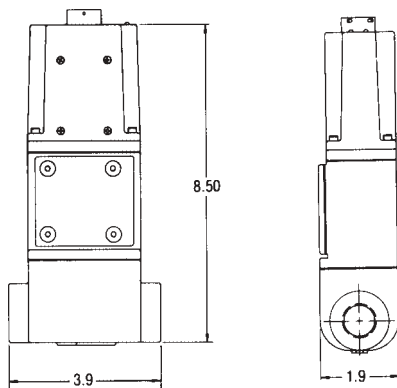

#### FEATURES

- Combines PV1 with Master Flow regulator
- Compact size
- Minimal droop
- Piston operated for long life
- Self relieving
- In-line mounting
- Modular design for ease of maintenance
- Compact size to flow ratio
- Rugged anodized aluminum construction
- Optional pressure ranges available for specific application (100 psi max.)

The proportional control valve is mounted to Alkon's own precision pilot operated regulator assembly.

Available in 1/2" and 3/4" NPT, it offers tremendously high air flow capabilities (390 SCFM). With a precision-regulated range of 5-100 psi (standard), it experiences minimal hysteresis while maintaining exceptional repeatability, sensitivity, and resolution. It is a rugged compact design, easily mounted in-line for a multitude of applications.

#### PERFORMANCE SPECIFICATIONS

| Electrical                      | Min. | Typ. | Max. | Units    |
|---------------------------------|------|------|------|----------|
| Regulated Output                |      |      |      |          |
| Pressure                        | 0    |      | 100  | psi      |
| Input Pressure                  | 8    |      | 125  | psi      |
| Temperature                     | 0    |      | 60   | °C       |
| Combined Linearity & Hysteresis |      | 2.5  | 3.5  | ±% Range |
| Repeatability                   |      | 2.5  | 3.5  | ±% Range |
| Sensitivity                     |      | 2.5  | 3.5  | ±% Range |
| Resolution                      |      | 2.5  | 3.5  | ±% Range |

#### Flow Characteristics

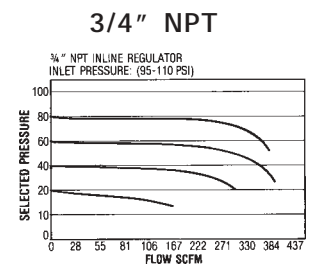
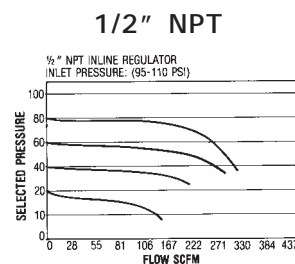

### AU1 and AU2 INTERPOSED PROPORTIONAL REGULATOR & VALVE COMBINATION

#### FEATURES

- Up to 300 SCFM
- Single and dual regulation
- Control range - 0 to 100 psi
- Automotive interface design
- Base or manifold mounting

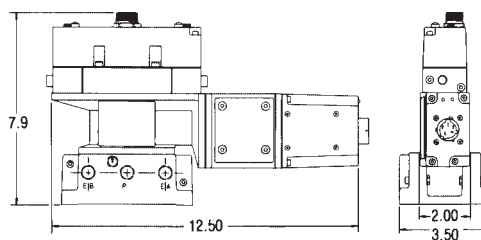

Interposed (directional valve)

U.S. Patent No. 5,327,926

The industries first proportional regulation system designed specifically for a directional valve. The AU1 and AU2 5-ported valve package covers 1/8" thru 3/4" port sizes with flows of 1.4 to 6.6 Cv . This unique Alkon design offers *no flow reduction* with interposed regulation as do all other currently available valve packages on the market today.



# PROPORTIONAL CONTROL VALVES

---

## TYPICAL APPLICATIONS

- Precise multi-pressure weld selection
- Air motor speed control
- Tension control
- Paint spray pressure control
- Single acting cylinder control
- Air motor torque control
- Air adhesive dispensing control
- Gripper control
- Counter balance cylinder control

## ORDERING INFORMATION

### Proportional Valve

| <u>Model</u> | <u>Description</u>                |
|--------------|-----------------------------------|
| PV1-3        | Analog input Proportional valve   |
| PV1-4        | 4-20 ma. input Proportional valve |
| PV1-5        | Digital input Proportional valve  |

**In-Line Regulator:** 1/2 and 3/4 NPT Female inlet/outlet ported in-line regulator, proportional controlled. Analog feedback with lights and T.T.L. output.

| <u>Model</u> | <u>Description</u>                       |
|--------------|--|
| MFPV1-50-3   | 1/2 NPT inlet/outlet with analog input   |
| MFPV1-50-4   | 1/2 NPT inlet/outlet with 4-20 ma. input |
| MFPV1-50-5   | 1/2 NPT inlet/outlet with digital input  |
| MFPV1-75-3   | 3/4 NPT inlet/outlet with analog input   |
| MFPV1-75-4   | 3/4 NPT inlet/outlet with 4-20 ma. input |
| MFPV1-75-5   | 3/4 NPT inlet/outlet with digital input  |

### Interposed Regulator (for sub-based directional valves)\*\*

Single proportional regulators for the "Indy" series AU1 & AU2 valves or equivalent. Analog feedback with lights\* and T.T.L. output. Dual proportional regulation available upon request.

| <u>Model</u> | <u>Description</u>                               |
|--------------|--|
| AU1-SPR-3    | Analog input for AU1 series, single regulation   |
| AU1-SPR-4    | 4-20 ma. input for AU1 series, single regulation |
| AU1-SPR-5    | Digital input for AU1 series, single regulation  |
| AU2-SPR-3    | Analog input for AU2 series, single regulation   |
| AU2-SPR-4    | 4-20 ma. input for AU2 series, single regulation |
| AU2-SPR-5    | Digital input for AU2 series, single regulation  |

\*Red power light, green pressure-achieved light.

\*\*To select directional valve to complete this unit, see Indy Series section in this catalog.



## PROPORTIONAL CONTROL VALVES

---

### CONNECTOR PINOUT INFORMATION

#### Model PV1-3 (Analog Input)

| <u>Pin</u> | <u>Description</u>             |
|------------|--------------------------------|
| A          | GROUND                         |
| B          | + SUPPLY VOLTAGE               |
| C          | ANALOG CONTROL VOLTAGE         |
| D          | ANALOG FEEDBACK OUTPUT VOLTAGE |
| E          | TTL OPEN COLLECTOR OUTPUT      |

#### Model PV1-5 (Digital Input)

| <u>Pin</u> | <u>Description</u>             |
|------------|--------------------------------|
| A          | + SUPPLY VOLTAGE               |
| B          | ANALOG FEEDBACK OUTPUT VOLTAGE |
| C          | D0 DIGITAL INPUT               |
| D          | D1 DIGITAL INPUT               |
| E          | D2 DIGITAL INPUT               |
| F          | D3 DIGITAL INPUT               |
| G          | D4 DIGITAL INPUT               |
| H          | D5 DIGITAL INPUT               |
| J          | D6 DIGITAL INPUT               |
| K          | D7 DIGITAL INPUT               |
| L          | GROUND                         |
| M          | TTL OPEN COLLECTOR OUTPUT      |

### CABLE/CONNECTOR ASSEMBLY

Alkon offers a series of shielded cable/connector assemblies to enhance the performance of the proportional control valve. For operations that require extensive cable flexing (moving units, robots, etc.) we recommend the braided cable. For operations that involve excessive moisture we recommend the splash-proof cable. In all cases, customer should specify 3, 6, or 12 ft. length. For special lengths consult factory.

#### Ordering Information for Cable/Connector Assembly

| <u>Model</u> | <u>Description</u>  |
|--------------|---|
| 90A50052*    | Shielded cable assembly, analog                             |
| 90A50053*    | Shielded cable w/ splash-proof connector, analog            |
| 90A50054*    | Shielded & braided cable assembly, analog                   |
| 90A50055*    | Shielded & braided cable w/ splash-proof connector, analog  |
| 90A50056*    | Shielded cable assembly, digital                            |
| 90A50057*    | Shielded cable assembly w/ splash-proof connector, digital  |
| 90A50058*    | Shielded & braided cable assembly, digital                  |
| 90A50059*    | Shielded & braided cable w/ splash-proof connector, digital |

\* Connector included, specify 3, 6, or 12 ft. length

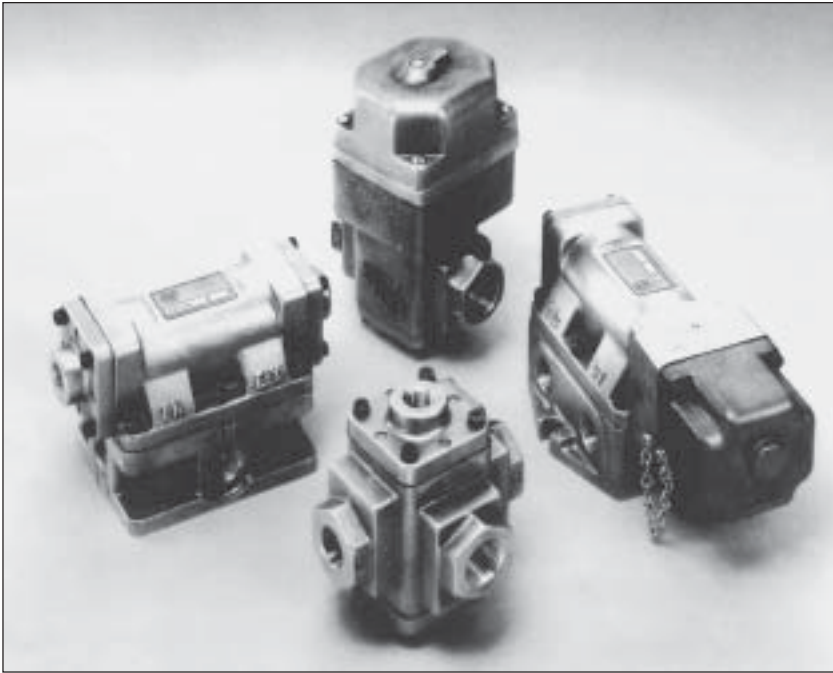

### Solenoid Data

#### "VP" Solenoid

- Solenoid-Manual Override Standard
- Inrush Current @ 120V = .26 amps
- Holding Current .16 amps
- Coils are molded epoxy and rated for continuous duty.

#### Direct Solenoid

- Standard (AC) voltage 115v/60 Hz
  - Electrical Data
 

|                              |          |         |
|------------------------------|----------|---------|
|                              | Inrush   | Holding |
| 1/2- 3/4 NPTF Voltage 115/60 | 4.2 amps | .6 amps |
- Solenoids are rated for continuous duty.

### Air Flow @ 80 PSIG (SCFM)

|       | 1/2 | 3/4 | 1 | 1-1/4 |
|-------|-----|-----|---|-------|
| 2-Way | 230 | 259 |   |       |
| 3-Way | 244 | 268 |   |       |
| 4-Way | 197 | 197 |   |       |

### Cv Factor

| Port Size | 1/2 | 3/4 | 1 | 1-1/4 |
|-----------|-----|-----|---|-------|
| NPTF      | 1/2 | 3/4 | 1 | 1-1/4 |
| 2-Way     | 4.9 | 5.5 |   |       |
| 3-Way     | 5.2 | 5.7 |   |       |
| 4-Way     | 4.2 | 4.2 |   |       |



## DETROIT LINE

### Engineering Data for all Detroit Line Valves

#### Lubrication

All Alkon valves are pre-lubricated with PTFE-based grease and will operate dry (with no additional lubrication) however, a lubricated system will greatly extend the service life of any valve. The following oils are popular, easily obtained fluids that are recommended for use with Alkon valves; Gulf Harmony 47, Mobil DTE Medium, Shell Tellus 29, Texaco Rondo B. Schvis 47 and Sunnis 921. Many other fluids are acceptable lubricants providing they do not contain detergents that will attack Buna N or Viton seals.

#### Spool Replacement for Detroit Line Valves

| Valve Model    | Part No. | Valve Model     | Part No. | Valve Model  | Part No. |
|----------------|----------|-----------------|----------|--------------|----------|
| NCVP21-S-50/75 | 90A20002 | 131-M-50/75     | 90A20004 | 41-S-50/75   | 90A20223 |
| NOVP21-S-50/75 | 90A20009 | 132-M-50/75     | 90A20004 | 42-S-50/75   | 90A20224 |
| VP22-S-50/75   | 90A20002 | 131-S-50/75     | 90A20222 | 41-M-50/75   | 90A20006 |
| NC21-S-50/75   | 90A20026 | 132-S-50/75     | 90A20036 | 42-M-50/75   | 90A20015 |
| NO21-S-50/75   | 90A20032 | NCVP131-S-50/75 | 90A20004 | VP41-S-50/75 | 90A20006 |
| 22-S-50/75     | 90A20034 | NOVP131-S-50/75 | 90A20004 | VP42-S-50/75 | 90A20006 |
| NC21-M-50/75   | 90A20002 | VP132-S-50/75   | 90A20004 | ASK-5945     | 90A20052 |
| NO21-M-50/75   | 90A20009 | 3072-C          | 90A20236 | ASK-5946     | 90A20052 |
| 22-M-50/75     | 90A20002 |                 |          | ASK-594      | 90A20098 |

#### Detroit Line Specifications

- Operating Pressure Range - 28" Mercury Vacuum to 125 PSIG, "VP" Pilot and Air Pilot Require Minimum of 30 PSIG to Shift Spool.
- Temperature Range - 40° to 180° F. For Higher Temperatures Consult Factory.
- Viton Seals Standard on All Models.
- Explosion Proof Housings Meet - Class I Groups C & D, Class II Groups E, F, & G.

#### Glass Industry Specifications

- Cv = 6.1
- Minimum Pilot Supply: 20 psig
- Maximum Working Pressure: 125 psig
- Temperature Range: 40° to 350° F
- PTFE-impregnated Viton Seals
- Exclusive Thin Lip Seal Design
- Spool Position Indicator Standard
- Minimal Parts for Ease of Maintenance
- Supplied Worldwide Through Alkon Distributors
- Lube Port Option Available
- Solenoid Versions with Spool Position Indicators Available
- Single and Dual Pilot Isolation Available
- Cv = 6.1 Tested on "ASK" Base

## Air Pilot Operated Valves

Air Pilot operated valves are recommended where it is desirable to substitute pilot air circuitry to replace solenoid operated valves. Typical applications would be where electrically operated valving would present a fire or explosion hazard. With controlled pilot signals air pilot systems have comparable response to electrically operated valves and in many cases system response is enhanced by their use.

### Specifications:

Operating Pressure: (Main Valve) vacuum - 150 psig

Pilot Pressure Required: 30 psig

- For Normally Open 3-Way, Supply Port 3

## "VP" Series Solenoid Pilot Operated

### Features:

- Meets All J.I.C. & Industrial Standards
- Molded Coils are Standard
- Fast Response and Low Inrush Current
- Rugged Cast Aluminum Design
- High Air Flow Capability
- Delivers Millions of Trouble Free Cycles

### Available In:

- 2, 3 or 4-Way Models
- Single or Double Solenoid
- Standard Voltages: 120/60Hz, 240/60Hz, 24/60Hz, 12VDC, 24VDC, 120VDC
- Also Available with 3-Prong MS Electrical Connector (Consult Factory)
- External Pilot Provision is field convertible - consult factory

## Direct Solenoid Operated

Alkon direct operated solenoid valves are excellent for vacuum or low pressure service or where application demands extremely fast response independent of operating pressure. Complete piping versatility for 3-Way models is also featured.

### Available With:

- Single or Double Solenoid
- DC Solenoids (Consult Factory)
- Base Mounting Models on 4-Ways
- Manual Override is Standard on all Models
- Explosion Proof Models - (AC Only) Add Suffix "X" to end of model number

### Features:

- Fast Response...Minimum Breakdown Friction
- Minimum Moving Parts
- Valves May Be Mounted in Any Position
- Inlet and Outlet Ports May Be Restricted, Plugged or Used for Alternative Pressure Arrangements Without Affecting Operation of Valve
- All Models Conform to J.I.C. and Industrial Standards
- Standard Voltage 115/60Hz
- For Normally Open 3-Way, Supply Port 3

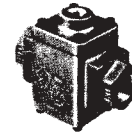

**2-Way Line Mounted**



**3-Way Line Mounted**  
These 3-Way valves may be used normally open, normally closed, as a selector or directional valve without modification.

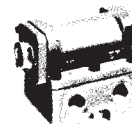

**4-Way Base Mounted**



**2-Way Line Mounted**



**3-Way Line Mounted**

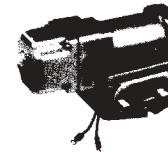

**4-Way Base Mounted**



**2-Way Line Mounted**



**3-Way Line Mounted**  
These 3-Way valves may be used normally open, normally closed, as a selector or directional valve without modification.



**4-Way Base Mounted**



## DETROIT LINE

|  |  |  |  |   |
|--|--|--|--|---|
| <p><b>2-Way</b></p> <p><b>Single Air Pilot</b>      <b>Double Air Pilot</b></p>  |  | <p><b>Port Size NPTF</b></p> <p>Single _____ 1/2<br/>                          3/4</p> <p>Double _____ 1/2<br/>                          3/4</p> | <p><b>Model No.</b></p>  | <p><b>Dimensions</b></p> <p><b>L      H      W</b></p> <p>4-1/8    3-3/4    2-1/8<br/>4-1/8    3-3/4    2-1/8<br/>4-1/8    3-3/4    2-1/8<br/>4-1/8    3-3/4    2-1/8</p>         |
| <p><b>3-Way</b></p> <p><b>Air Pilot Spring Return</b>      <b>Double Air Pilot</b></p>   |  | <p>Single _____ 1/2<br/>                          3/4</p> <p>Double _____ 1/2<br/>                          3/4</p>                              | <p>131-M-50<br/>131-M-75<br/>132-M-50<br/>132-M-75</p>               | <p>4-1/8    4-1/2    3-1/2<br/>4-1/8    4-1/2    3-1/2<br/>4-1/8    4-1/2    3-1/2<br/>4-1/8    4-1/2    3-1/2</p>  |
| <p><b>4-Way</b></p> <p><b>Air Pilot Spring Return</b>      <b>Double Air Pilot</b></p>   |  | <p>Single _____ 1/2<br/>                          3/4</p> <p>Double _____ 1/2<br/>                          3/4</p>                              | <p>41-M-50<br/>41-M-75<br/>42-M-50<br/>42-M-75</p>                   | <p>5-3/16    3-1/4    4-1/2<br/>6-1/2     3-3/4    4-1/2<br/>6-1/2     3-3/4    4-1/2<br/>6-1/2     3-3/4    4-1/2</p>  |
| <p><b>2-Way</b></p> <p><b>Single Solenoid Normally Closed Single Solenoid Air Pilot (Maintained Contact)</b>      <b>Double Solenoid Air Pilot (Momentary Contact)</b></p> |  | <p>Single _____ 1/2<br/>                          3/4</p> <p>Double _____ 1/2<br/>                          3/4</p>                              | <p>*NCVP21-S-50<br/>*NCVP21-S-75<br/>VP22-S-50<br/>VP22-S-75</p>     | <p><b>Dimensions</b></p> <p><b>L      H      W</b></p> <p>4-1/8    5-27/32    2-1/2<br/>4-1/8    5-27/32    2-1/2<br/>4-1/8    8-27/32    2-1/2<br/>4-1/8    8-27/32    2-1/2</p> |
| <p><b>3-Way</b></p> <p><b>Single Solenoid Normally Closed Single Solenoid Air Pilot</b>      <b>Double Solenoid Air Pilot</b></p>  |  | <p>Single _____ 1/2<br/>                          3/4</p> <p>Double _____ 1/2<br/>                          3/4</p>                              | <p>*NCVP131-S-50<br/>*NCVP131-S-75<br/>VP132-S-50<br/>VP132-S-75</p> | <p>4-1/8    7      3-5/16<br/>4-1/8    7      3-5/16<br/>4-1/8    9-7/16    3-5/16<br/>4-1/8    9-7/16    3-5/16</p>  |
| <p><b>4-Way</b></p> <p><b>Single Solenoid Air Pilot (Maintained Contact)</b>      <b>Double Solenoid Air Pilot (Momentary Contact)</b></p>                                 |  | <p>Single _____ 1/2<br/>                          3/4</p> <p>Double _____ 1/2<br/>                          3/4</p>                              | <p>VP41-S-50S<br/>VP41-S-75-S<br/>VP42-S-50<br/>VP42-S-75</p>        | <p>7-31/32    3-7/8    4-5/16<br/>7-31/32    3-7/8    4-5/16<br/>10-7/8     3-7/8    4-5/16<br/>10-7/8     3-7/8    4-5/16</p>  |
| <p><b>2-Way</b></p> <p><b>Single Direct Solenoid (Maintained Contact)</b>      <b>Double Direct Solenoid (Momentary Contact)</b></p>                                       |  | <p>Single _____ 1/2<br/>                          3/4</p> <p>Double _____ 1/2<br/>                          3/4</p>                              | <p>*NC21-S-50<br/>*NC21-S-75<br/>22-S-50<br/>22-S-75</p>             | <p><b>Dimensions</b></p> <p><b>L      H      W</b></p> <p>4-1/8    6-5/16    3-5/16<br/>4-1/8    9-21/32    3-5/16</p>  |
| <p><b>3-Way</b></p> <p><b>Single Solenoid Normally Closed Single Direct Solenoid (Maintained Contact)</b>      <b>Double Direct Solenoid (Momentary Contact)</b></p>       |  | <p>Single _____ 1/2<br/>                          3/4</p> <p>Double _____ 1/2<br/>                          3/4</p>                              | <p>131-S-50<br/>131-S-75<br/>132-S-50<br/>132-S-75</p>               | <p>4-1/8    7      3-15/32<br/>4-1/8    10-3/8    3-15/32</p>   |
| <p><b>4-Way</b></p> <p><b>Single Direct Solenoid (Maintained Contact)</b>      <b>Double Direct Solenoid (Momentary Contact)</b></p>                                       |  | <p>Single _____ 1/2<br/>                          3/4</p> <p>Double _____ 1/2<br/>                          3/4</p>                              | <p>41-S-50<br/>41-S-75<br/>42-S-50<br/>42-S-75</p>                   | <p>8-7/16    4-1/8    4-1/2<br/>11-13/16    4-1/8    4-1/2</p>  |

Normally Open = Supply Port 3.

**Port Size NPTF**

**Model No.**

**Dimensions**

**L      H      W**

Single \_\_\_\_\_ 1/2  
                          3/4

Double \_\_\_\_\_ 1/2  
                          3/4

\*NCVP21-S-50  
\*NCVP21-S-75  
VP22-S-50  
VP22-S-75

4-1/8    5-27/32    2-1/2  
4-1/8    5-27/32    2-1/2  
4-1/8    8-27/32    2-1/2  
4-1/8    8-27/32    2-1/2

Single \_\_\_\_\_ 1/2  
                          3/4

Double \_\_\_\_\_ 1/2  
                          3/4

\*NCVP131-S-50  
\*NCVP131-S-75  
VP132-S-50  
VP132-S-75

4-1/8    7      3-5/16  
4-1/8    7      3-5/16  
4-1/8    9-7/16    3-5/16  
4-1/8    9-7/16    3-5/16

Single \_\_\_\_\_ 1/2  
                          3/4

Double \_\_\_\_\_ 1/2  
                          3/4

VP41-S-50S  
VP41-S-75-S  
VP42-S-50  
VP42-S-75

7-31/32    3-7/8    4-5/16  
7-31/32    3-7/8    4-5/16  
10-7/8     3-7/8    4-5/16  
10-7/8     3-7/8    4-5/16

Single \_\_\_\_\_ 1/2  
                          3/4

Double \_\_\_\_\_ 1/2  
                          3/4

\*NC21-S-50  
\*NC21-S-75  
22-S-50  
22-S-75

**Dimensions**

**L      H      W**

4-1/8    6-5/16    3-5/16  
4-1/8    9-21/32    3-5/16

Single \_\_\_\_\_ 1/2  
                          3/4

Double \_\_\_\_\_ 1/2  
                          3/4

131-S-50  
131-S-75  
132-S-50  
132-S-75

4-1/8    7      3-15/32  
4-1/8    10-3/8    3-15/32

Normally Open = Supply Port 3.

Single \_\_\_\_\_ 1/2  
                          3/4

Double \_\_\_\_\_ 1/2  
                          3/4

41-S-50  
41-S-75  
42-S-50  
42-S-75

8-7/16    4-1/8    4-1/2  
11-13/16    4-1/8    4-1/2

### Operators

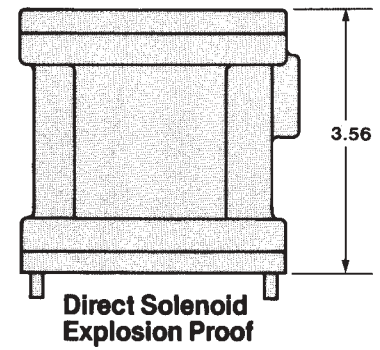
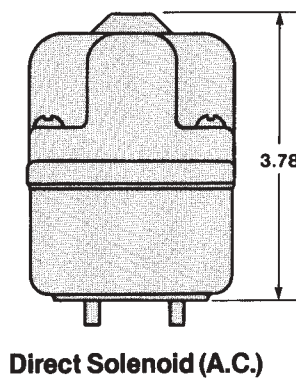
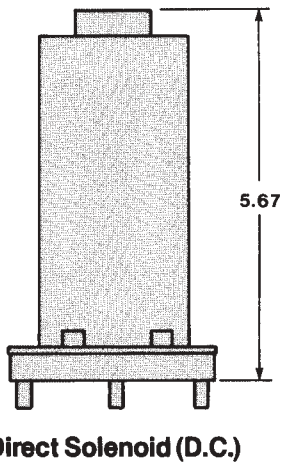
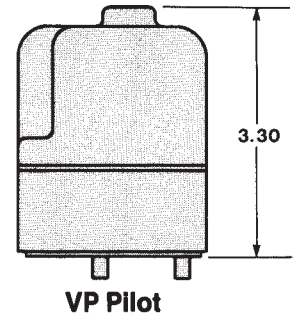
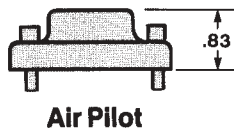
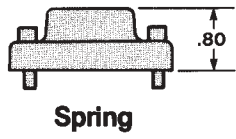

### Body Styles

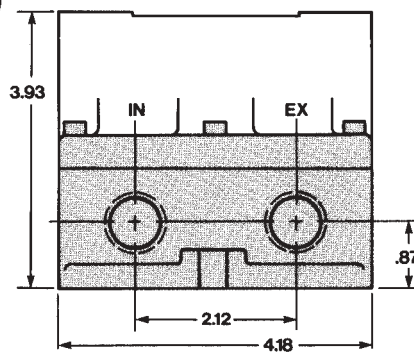
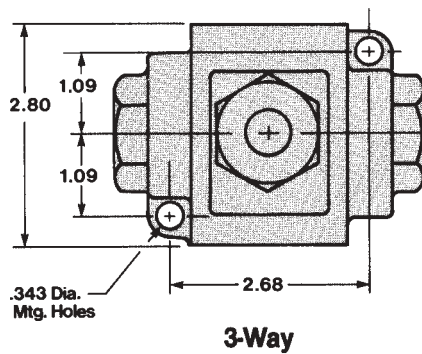
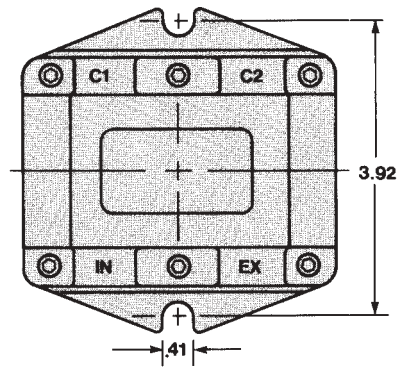
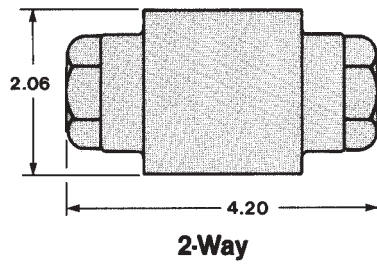



**ALCON**

## DETROIT LINE FOR GLASS INDUSTRY

### AIR PILOT OPERATED VALVES

Air pilot operated valves are recommended for applications where the substitution of pilot air circuitry for solenoid operated valves is more suitable.

Controlled pilot signals using pilot air systems show comparable response to electrically operated valves, and in many cases, response is enhanced by their use.

3-way valves may be used normally open, normally closed, or as a selector or directional valve without modification. They are operated with a air pilot signal.

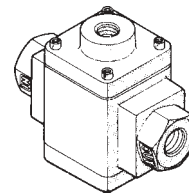

2-Way  
Line Mounted

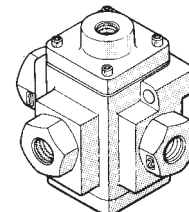

3-Way  
Line Mounted

### ASK594 Valve

The ASK594 Valve was first developed in 1963 for the glass making machine industry. It is basically a 4-Way, air pilot, spring return valve with a visual indicator. The base may be mounted directly on top of a cylinder with porting conforming to the "SK" base interface. The base, exhaust restrictors, and isolation valve are optional. The ASK is the newest version of the same valve.

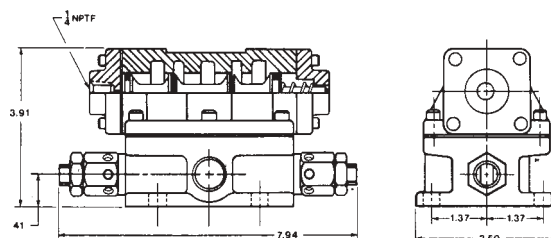

| Model #   | Description   |
|-----------|---|
| ASK-594V  | Valve on base, no indicator with exhaust restrictors      |
| ASK-5645V | Valve on base, with indicator with exhaust restrictors    |
| ASK-5946V | Valve on base, with indicator without exhaust restrictors |

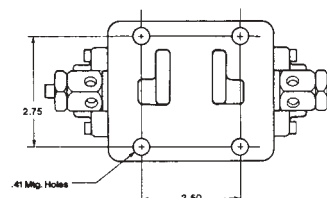

**Note:** Specify less base, if base is not needed.

### 3072-C Isolation Valve

This functional unit easily adapts to the ASK594 valve to provide a quick manual system shutdown. Although the ASK 594 normally operates as a 4-Way air piloted valve, by inserting the 3072-C between the air pilot end cap and the valve body, the air pilot signal is blocked to the main valve and the ASK spool returns to a de-energized position.

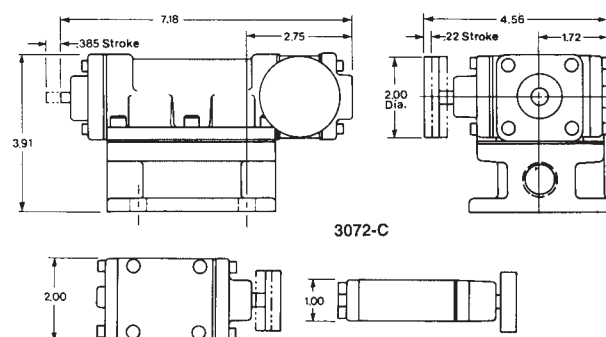

### SP-3207 Dual Isolation Valve

Just like the 3072-C, this valve adapts easily to the ASK594 valve to provide a quick manual system shutdown while, at the same time, blocking the signal to another remote valve in the system. This provides a simultaneous isolation of the dual pilots.

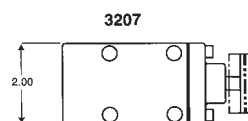



**ALKON CORPORATION**

728 Graham Drive Fremont, Ohio 43420

419-333-7000 • FAX 419-355-9211

E-mail: [sales@alkoncorp.com](mailto:sales@alkoncorp.com)

web site: [www.alkoncorp.com](http://www.alkoncorp.com)

