



# Gate Valve Index

Press. Class	Material	Bonnet Joint	End Connection	Bonnet Type	SERIES
150	A105	Bolted	Flanged	OS&Y	353
			Butt Weld	OS&Y	BW353
			Thd/SW	OS&Y	See Class 800
	A182 F316/F316 L	Bolted	Flanged	OS&Y	358
	A350 LF2	Bolted	Flanged	OS&Y	32353
300	A105	Bolted	Flanged	OS&Y	363
			Butt Weld	OS&Y	BW363
			Thd/SW	OS&Y	See Class 800
	A182 F316/F316 L	Bolted	Flanged	OS&Y	368
	A350 LF2	Bolted	Flanged	OS&Y	32363
600	A105	Bolted	Flanged	OS&Y	373, 13373, 11403
			Butt Weld	OS&Y	BW373
			Thd/SW	OS&Y	See Class 800
	A182 F316/F316 L	Bolted	Flanged	OS&Y	378
	A350 LF2	Bolted	Flanged	OS&Y	32373
800	A105	Bolted	Threaded	OS&Y	12111, 13111, 11103
				ISS	12161
			Socket Weld	OS&Y	SW12111, SW13111, SW11103
				ISS	SW12161
			Male Thd x Fem Thd	OS&Y	TT12111
			Male Soc x Fem Thd	OS&Y	ST 12111
		Male Cpt x Fem Thd	OS&Y	CT12111	
		Weld	Threaded	OS&Y	2801, 2801B
				ISS	2811
			Socket Weld	OS&Y	SW2801, SW2801B
				ISS	SW2811
			Male Thd x Fem Thd	OS&Y	TT2801
				ISS	TT2811
			Male Soc x Fem Thd	OS&Y	ST2801
			Male Cpt x Fem Thd	OS&Y	CT 2801, CT 2901
	Union		Threaded	ISS	59851
		Socket Weld	ISS	SW59851	
	A350 LF2	Bolted	Threaded	OS&Y	32111
			Socket Weld	OS&Y	SW32111
	A182 F3/F316L	Bolted	Threaded	OS&Y	12401, 13401
			Socket Weld	OS&Y	SW12401, SW13401
		Weld	Threaded	OS&Y	2831
			Socket Weld	OS&Y	SW2831
			Male Thd x Fem Thd	OS&Y	TT2831
			Male Soc x Fem Thd	OS&Y	ST2831
			Male Cpt x Fem Thd	OS&Y	CT2831
Union			Threaded	ISS	59951
		Socket Weld	ISS	SW59951	
A182 F316H		Bolted	Threaded	OS&Y	82401
		Socket Weld	OS&Y	SW82401	
A182 F5	Bolted	Threaded	OS&Y	12421	
		Socket Weld	OS&Y	SW12421	
A182 F9	Bolted	Threaded	OS&Y	12921	
		Socket Weld	OS&Y	SW12921	



## Gate Valve Index *(cont.)*

Press. Class	Material	Bonnet Joint	End Connection	Bonnet Type	SERIES
800 (cont.)	A182 F11, CL2	Bolted	Threaded	OS&Y	12321
			Socket Weld	OS&Y	SW12321
	A182 F22 CL 3	Bolted	Threaded	OS&Y	12521
			Socket Weld	OS&Y	SW12521
1500	A105	Bolted	Threaded	OS&Y	15111, 16111, 1033, 1043
			Socket Weld	OS&Y	SW15111, SW16111, SW1043, SW1033
			Flanged	OS&Y	15373, 11603, 11683
		Weld	Threaded	OS&Y	15801
			Socket Weld	OS&Y	SW15801
			Male Cpt x Fem Thd	OS&Y	ST15801
	A350 LF2	Bolted	Threaded	OS&Y	35111
			Socket Weld	OS&Y	SW35111
	A182 F316/F316L	Bolted	Threaded	OS&Y	15401
			Socket Weld	OS&Y	SW15401
			Weld	Threaded	OS&Y
		Weld	Socket Weld	OS&Y	SW15831
			A182 F11, CL.2	Bolted	Threaded
	Socket Weld	OS&Y	SW15321		
2500	A105	Welded	Threaded	OS&Y	66703
			Socket Weld	OS&Y	SW66703
	A182 F11, CL2	Welded	Threaded	OS&Y	66713
			Socket Weld	OS&Y	SW66713
	A182 F22, CL.3	Welded	Socket Weld	OS&Y	SW66773

## Description of Series Number System for Vogt Valves (Order Vogt Valves & Fittings by size—series number)

**Prefix:**

This maximum 3 alphanumeric letter beginning the Vogt Valve series number is normally indicative of the valve connection. Historically, a few design features have also been used as part of the prefix including **S**, **B** and **R**. A fully female threaded valve as the traditional Vogt standard does not have a prefix number (see below for prefix descriptions).

**Prefix Description:**

- (Blank)** - Female NPT (both ends)
- B** - Ball Check (female NPT)
- BS** - Female SW by Male Butt Weld
- BT** - Female Thd by Male Butt Weld
- BW** - Butt Weld
- CS** - Female SW by Male Couplet
- CT** - Female Thd by Male Couplet
- R** - In-Line Repair (female NPT)
- RJ** - Ring Joint Flanges
- S** - Swing Check (female NPT)
- SS** - Female SW by Male SW
- ST** - Female Thd by Male SW
- SW** - **Socket Weld**
- SWB** - Ball Check (SW)
- SWR** - In-line Repairable (SW)
- SWS** - Swing Check (SW)
- TS** - Female SW by Male Thd
- TSW** - Female Thd by Female SW
- TT** - Female Thd by Male Thd

**Legend:**

The prefixes and suffixes based on design are limited to **S**, **B**, **R** and **ER** (as listed above) **ONLY**.

Expansion of new valve designs are added as new SERIES NUMBERS.

(See the VV 200 individual pages for standard series available.)

**Suffix:**

This maximum 3 alphanumeric character ending of the Vogt Valve series number is normally indicative of the valve internal trim package. Historically, packing and a few design features have also been used as part of the suffix number including **T**, **B** and **ER**. A valve with the traditional Vogt standard trim package and packing is not assigned a suffix number (see below for suffix descriptions).

**Suffix Description:**

- (Blank)** – Standard Trim
- B** – Bellows Valve
- C** – Cryogenic Valve
- CL** – Chlorine Valve Trim – Monel/Hastelloy
- ER** – Emissions Reduction – Double Packed with Lantern Ring
- F8M**– 316 Trim
- FHF** – Full Hard Face (unless standard)
- FH8** – Full Hard Faced F8M Trim
- FHT** – Teflon Packing and Full Hard Face
- HF** – Hard Faced Disc (F316 Globes and Checks Only)
- HF2** – UOP Alkylation
- HF4** – UOP Alkylation
- HF5** – UOP Alkylation
- HF6** – UOP Alkylation
- HF7** – UOP Alkylation
- L** – Locking Device
- MB6** – 13% Chrome Trim – NACE
- MB8** – 316 Trim Hard Faced Seats and Disc/Wedge – NACE
- MBS** – Monel Trim – NACE
- MM** – Monel Trim – Grafoil Packing and Gasket
- MMP** – Phillips Alkylation
- MMT** – Monel Trim – Teflon Packing and Gasket
- MT** – Chlorine Valve Trim – Monel/Teflon Disc/Hastelloy
- MTG** – Vogt Alkylation
- MTP** – Phillips Alkylation
- R**– Reactive Seal
- T** – Teflon Packing and Gasket
- ZLB** – Zero Leakage Check Valve – Buna N
- ZLE** – Zero Leakage Check Valve – Ethylene Propylene
- ZLN** – Zero Leakage Check Valve – Neoprene
- ZLV** – Zero Leakage Check Valve – Viton 14

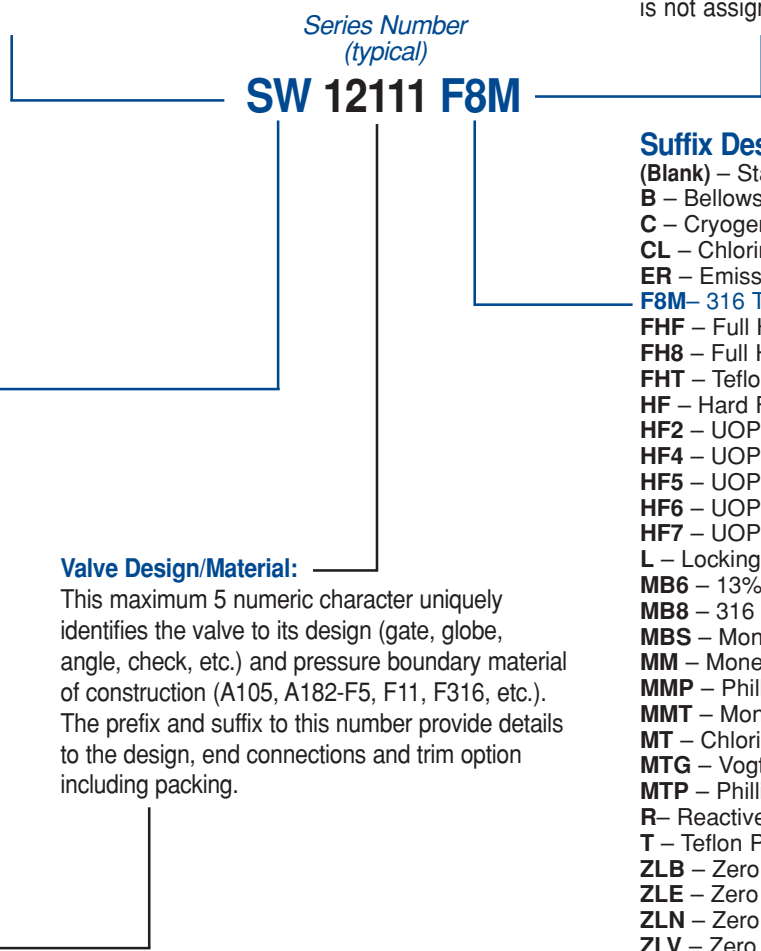

## Gate Valve Section – Pages 5-43

Gate valves are designed to operate in a fully open or fully closed position. When open, the media will flow with minimal turbulence and pressure drop through the valve.

Vogt gate valves are available with a variety of bonnet types, body and trim materials and stem packings in addition to a broad range of pressure classes, and end connections including extended bodies.

The rugged construction of FORGED gate valves provide an extended life of safe operation. Metal-to-metal seating surfaces accommodate the widest range of pressure-temperature service conditions.

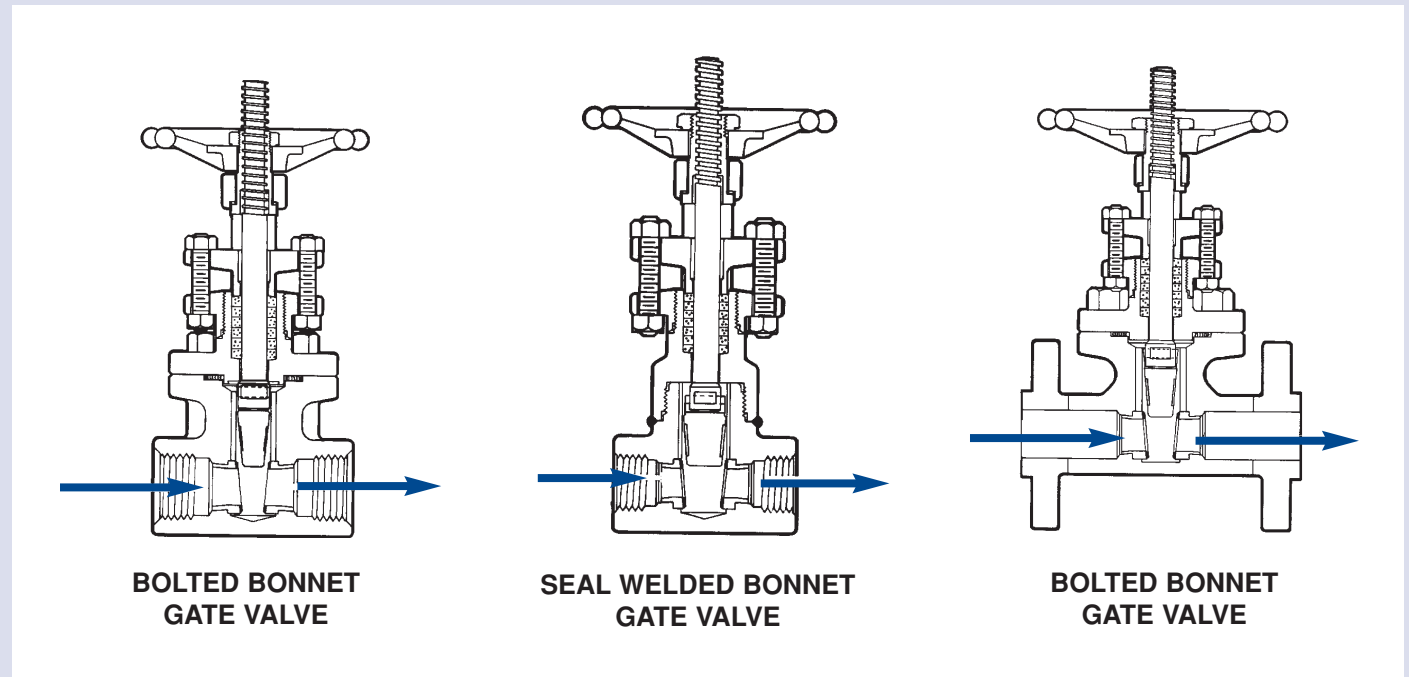

**Dimensions are in inches and millimeters.  
Dimensions are subject to change without notice.  
Order by Size and Series Number.**

# Forged Gate Valves

## Class 150 (PN 20)

Conventional Port

285 PSI @ 100°F (19.7 BAR @ 38°C)

For other ratings see pgs. 112-115

### A105 Body/Bonnet

SERIES NUMBER

353  
353T+ (Sizes 1/2-2")

Trim: 13% Cr.  
Seats: HF

353MB8

Trim: 316  
Wedge/Seats: HF

353MM

Trim: Monel

353FHF

Trim: 13% Cr.  
Wedge/Seats: HF

353F8M

Trim: 316  
Seats: HF

### A350 LF2 Body/Bonnet

32353

Trim: 13% Cr.  
Seats: HF

32353MB8

Trim: 316  
Wedge/Seats: HF

### F316/F316L

358

Trim: 316  
Seats: HF

### A105 Body/Bonnet

BW 353\* (Sizes 2"-4")  
(\*Same as BW363)  
(See page 7)

Trim: 13% Cr.  
Seats: HF

MATERIALS MEET  
REQUIREMENTS OF  
NACE STANDARD  
MR-01-75 FOR  
SOUR SERVICE

- Round Bolted Bonnet
- Spiral Wound Gasket
- Outside Screw & Yoke
- Bolted Gland
- Solid Wedge
- Hard Faced Seats
- API 602
- ASME B16.34

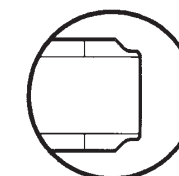
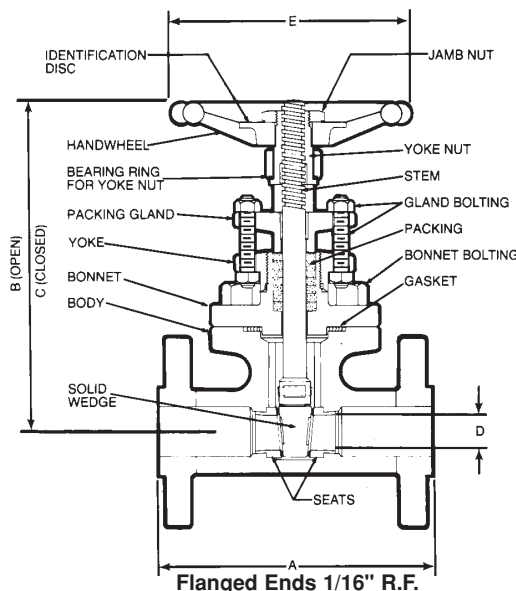

Butt Weld Ends  
Schedule 40

**Bold face numerals are in inches and pounds.**  
**Blue numerals are in millimeters and kilograms.**

## Dimensions

Size	NPS DN	1/2 15	3/4 20	1 25	1-1/2 40	2 50	3 80	4 100
A-End-to-End		4.25 108	4.62 117	5.00 127	6.50 165	7.00 178	8.00 203	9.00 229
B-Open		6.38 162	6.38 162	8.31 211	10.12 257	11.10 282	14.06 357	18.03 458
C-Closed		5.75 146	5.75 146	7.38 187	8.69 221	9.41 239	11.81 300	14.94 379
D-Seat Diameter		.50 12.7	.50 12.7	.75 19.1	1.25 31.8	1.50 38.1	2.00 50.8	2.75 69.8
E-Handwheel Diameter		4.00 102	4.00 102	4.75 121	5.75 146	7.00 178	8.00 203	9.75 248
Weight		6.6 3.0	7.7 3.5	12.1 5.5	23.0 10.4	31.8 14.4	57.4 26.1	99.8 45.3

+ Valves contain TEFLON—maximum temperature 500°F.  
Valve flanges conform to ASME Standard B16.5 and end-to-end dimensions conform to ASME Standard B16.10.

For Cv factors see page 123, Valve Matrix A.  
Refer to pages 116-120 for full materials description.

GATE  
CLASS 150 (PN 20)  
353, 32353, 358

## Forged Gate Valves

### Class 300 (PN 50)

#### Conventional Port

740PSI @ 100°F (51.0 BAR @ 38°C)

For other ratings see pgs. 112-115

#### A105 Body/Bonnet

##### SERIES NUMBER

- 363 Trim: 13% Cr. Seats: HF
- 363MB8 Trim: 316 Wedge/Seats: HF
- 363FHF Trim: 13% Cr. Wedge/Seats: HF
- 363MM Trim: Monel
- 13363MMP (Size 2" Only) (Full Port) Trim: Monel

Listed in Phillips Petroleum Company's HF Alkylation Process Design Spec. Manual.

- BW 363 (Sizes 2"-4") Trim: 13% Cr. Seats: HF
- BW 363F8M Trim: 316 Seats: HF
- BW 363MM Trim: Monel

#### A350 LF2 Body/Bonnet

- 32363 Trim: 13% Cr. Seats: HF
- 32363MB8 Trim: 316 Wedge/Seats: HF

#### F316/F316L

- 368 Trim: 316 Seats: HF

MATERIALS MEET REQUIREMENTS OF NACE STANDARD MR-01-75 FOR SOUR SERVICE

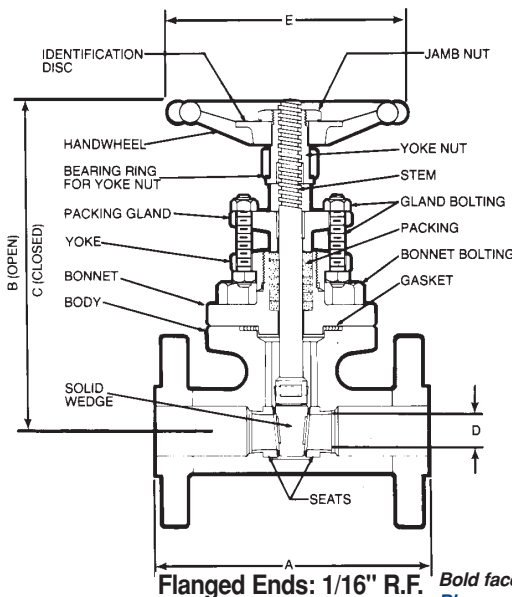

- Round Bolted Bonnet
- Spiral Wound Gasket
- Outside Screw & Yoke
- Bolted Gland
- Solid Wedge
- Hard Faced Seats
- API 602
- ASME B16.34

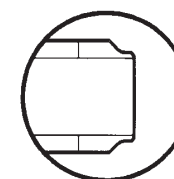

Butt Weld Ends  
Schedule 40

Flanged Ends: 1/16" R.F. *Bold face numerals are in inches and pounds. Blue numerals are in millimeters and kilograms.*

#### Butt Weld Ends:

Size	NPS DN	1/2	3/4	1	1-1/2	2	3	4	2	2-1/2	3	4
		15	20	25	40	50	80	100	50	65	80	100
A-End-to-End		5.50 140	6.00 152	6.50 165	7.50 190	8.50 216	11.12 282	12.00 305	8.50 216	9.50 241	11.12 282	12.00 305
B-Open		6.38 162	6.38 162	8.31 211	10.12 257	11.10 282	14.06 357	18.03 458	11.10 282	14.06 357	14.06 357	18.03 458
C-Closed		5.75 146	5.75 146	7.38 187	8.69 221	9.41 239	11.81 300	14.94 379	9.41 239	11.81 300	11.81 300	14.94 379
D-Seat Diameter		.50 12.7	.50 12.7	.75 19.1	1.25 31.8	1.50 38.1	2.00 50.8	2.75 69.8	1.50 38.1	2.00 50.8	2.00 50.8	2.75 69.8
E-Handwheel Diameter		4.00 102	4.00 102	4.75 121	5.75 146	7.00 178	8.00 203	9.75 248	7.00 178	8.00 203	8.00 203	9.75 248
Weight		8.0 3.6	10.9 4.9	15.4 7.0	29.2 13.3	39.6 18.0	67.5 30.6	127 57.7	24.9 11.3	34.2 15.5	44.2 20.1	77.1 35.0

Valve flanges conform to ASME Standard B16.5 and end-to-end Dimensions conform to ASME Standard B16.10.

For Cv factors see page 123, Valve Matrix A. Refer to pages 116-120 for full materials description.

GATE CLASS 300 (PN 50) 363, 13363MMP, 32363, 368

## Forged Gate Valves

### Class 600 (PN 110)

#### Conventional Port

1480 PSI @ 100°F

(102.1 BAR @ 38°C)

For other ratings see pgs. 112-115

#### A105 Body/Bonnet

##### SERIES NUMBER

- 373 Trim: 13% Cr. Seats: HF
- 373F8M Trim: 316 Seats: HF
- 373FHF Trim: 13% Cr. Wedge/Seats: HF
- 373MM Trim: Monel
- 373MB8 Trim: 316 Wedge/Seats: HF

#### A350 LF2 Body/Bonnet

- 32373 Trim: 13% Cr. Seats: HF
- 32373MB8 Trim: 316 Wedge/Seats: HF

#### F316/F316L

- 378 Trim: 316 Seats: HF

MATERIALS MEET REQUIREMENTS OF NACE STANDARD MR-01-75 FOR SOUR SERVICE

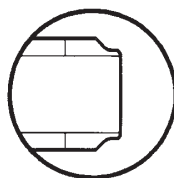

Butt Weld Ends  
Schedule 80

BW 373 (Sizes 2"-4")  
Trim: 13% Cr.  
Seats: HF

BW 373F8M  
Trim: 316  
Seats: HF

BW 373MM  
Trim: Monel

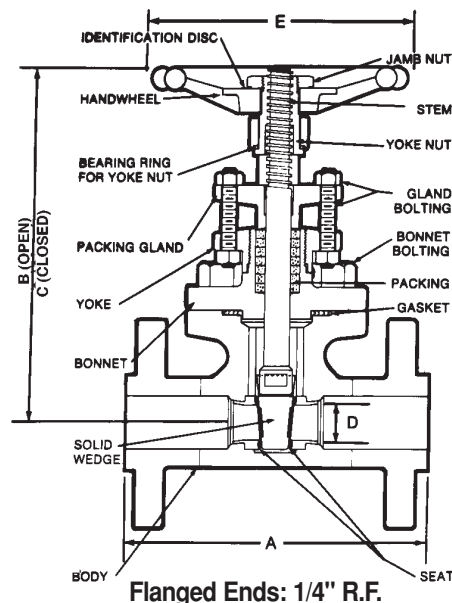

- Round Bolted Bonnet
- Spiral Wound Gasket
- Outside Screw & Yoke
- Bolted Gland
- Solid Wedge
- Hard Faced Seats
- API 602
- ASME B16.34

Flanged Ends: 1/4" R.F.

**Bold face numerals are in inches and pounds.**  
**Blue numerals are in millimeters and kilograms.**

## Dimensions

Size	NPS DN	Class 600 Conventional Port:							Butt Weld Ends:			
		1/2	3/4	1	1-1/2	2	3	4	2	2-1/2	3	4
A-End-to-End		6.50 165	7.50 190	8.50 216	9.50 241	11.50 292	14.00 356	17.00 432	11.50 292	13.00 330	14.00 356	17.00 432
B-Open		6.38 162	6.38 162	8.31 211	10.12 257	11.10 282	14.06 357	18.03 458	11.10 282	14.06 357	14.06 357	18.03 458
C-Closed		5.75 146	5.75 146	7.38 187	8.69 221	9.41 239	11.81 300	14.94 379	9.41 239	11.81 300	11.81 300	14.94 379
D-Seat Diameter		.50 12.7	.50 12.7	.75 19.1	1.25 31.8	1.50 38.1	2.00 50.8	2.75 69.8	1.50 38.1	2.00 50.8	2.00 50.8	2.75 69.8
E-Handwheel Diameter		4.00 102	4.00 102	4.75 121	5.75 146	7.00 178	8.00 203	9.75 248	7.00 178	8.00 203	8.00 203	9.75 248
Weight		8.3 3.8	12.0 5.4	17.2 7.8	30.0 13.6	40.8 18.5	83.5 37.9	166 75.4	30.0 13.6	51.5 23.4	49.3 22.4	88.0 40.0

Valve flanges conform to ASME Standard B16.5 and end-to-end dimensions conform to ASME Standard B16.10.

For Cv factors see page 123, Valve Matrix A.  
Refer to pages 116-120 for full materials description.

## Forged Gate Valves

### Class 600 (PN 110)

#### Full Port

1480 PSI @ 100°F  
(102.1 BAR @ 38°C)

For other ratings see pgs. 112-115

#### A105 Body/Bonnet

#### SERIES NUMBER

13373 Trim: 13% Cr.  
Seats: HF

13373MMP (Size 2" Only)  
Trim: Monel

Listed in Phillips Petroleum Company's HF Alkylation  
Process Design Spec. Manual.

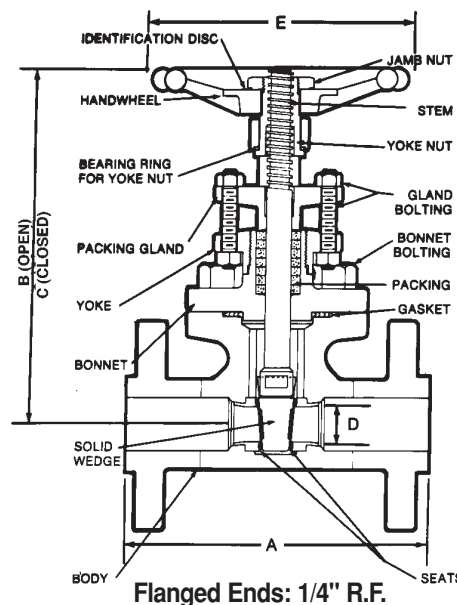

- Round Bolted Bonnet
- Spiral Wound Gasket
- Outside Screw & Yoke
- Bolted Gland
- Solid Wedge
- Hard Faced Seats
- API 602
- ASME B16.34

## Dimensions

**Bold face numerals are in inches and pounds.**  
**Blue numerals are in millimeters and kilograms.**

Size	NPS DN	1/2 15	3/4 20	1 25	1-1/2 40	2 50
A-End-to-End		6.50 165	7.50 190	8.50 216	9.50 241	11.50 292
B-Open		6.38 162	8.31 211	9.56 243	11.10 282	14.09 357
C-Closed		5.75 146	7.38 187	8.38 213	9.41 239	11.81 300
D-Seat Diameter		.50 12.7	.75 19.1	1.00 25.4	1.50 38.1	2.00 50.8
E-Handwheel Diameter		4.00 102	4.75 121	5.75 146	7.00 178	8.00 203
Weight		8.3 3.8	13.9 6.3	19.9 9.0	36.9 16.8	60.5 27.5

Valve flanges conform to ASME Standard B16.5 and end-to-end dimensions conform to ASME Standard B16.10.

For Cv factors see page 123, Valve Matrix B.  
Refer to pages 116-120 for full materials description.

## Forged Gate Valves

### Class 600 (PN 110)

Full Port (Except 2-1/2 & 3)

1480 PSI @ 100°F (102.1 BAR @ 38°C)

For other ratings see pgs. 112-115

A105 Body/Bonnet

SERIES NUMBER

11403

Trim: 13% Cr.  
Seats: HF

Meets API-600 required wall thicknesses

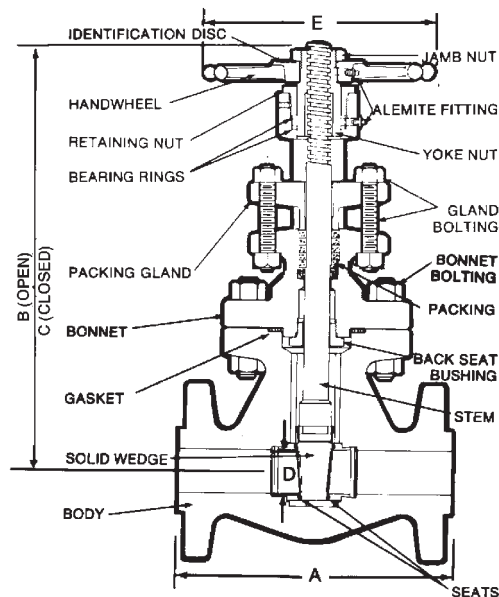

- Round Bolted Bonnet
- Spiral Wound Gasket
- Outside Screw & Yoke
- Bolted Gland
- Solid Wedge
- Hard Faced Seats
- ASME B16.34

### Dimensions

Flanged Ends: 1/4" R.F.

**Bold face numerals are in inches and pounds.**  
**Blue numerals are in millimeters and kilograms.**

Size	NPS DN	1/2 15	3/4 20	1 25	1-1/4 32	1-1/2 40	2 50	2-1/2 65	3 80
A-End-to-End		6.50 165	7.50 190	8.50 216	9.00 229	9.50 241	11.50 292	13.00 330	14.00 356
B-Open		10.44 265	11.31 287	12.56 319	14.12 359	16.38 416	19.00 483	21.75 552	24.00 610
C-Closed		9.69 246	10.38 264	11.44 291	12.62 321	14.69 373	16.81 427	19.00 483	20.75 527
D-Seat Diameter		.56 14.2	.75 19.1	1.00 25.4	1.25 31.8	1.50 38.1	2.00 50.8	2.31 58.7	2.81 71.4
E-Handwheel Diameter		4.75 121	5.75 146	7.00 178	8.00 203	9.75 248	9.75 248	12.00 305	13.75 349
Weight		19.5 8.9	31.2 14.2	45.0 20.4	57.4 26.1	76.2 34.6	105 47.7	169 76.7	220 99.9

Valve flanges conform to ASME Standard B16.5 and end-to-end dimensions conform to ASME Standard B16.10.

For Cv factors see page 123, Valve Matrix C.  
Refer to pages 116-120 for full materials description.

## Forged Gate Valves For HF Alkylation Service

### Class 800 (PN 130)

#### Conventional Port

1975 PSI @ 100°F (136.2 BAR @ 38°C)

For other ratings see pgs. 112-115

#### A105 Body/Bonnet

*SERIES NUMBER*

Threaded 42211MTG+  
 Socket Weld SW42211MTG+  
 Trim: Monel

### Class 800 (PN 130)

#### Full Port

1975 PSI @ 100°F (136.2 BAR @ 38°C)

For other ratings see pg. 121

#### A105 Body/Bonnet

*SERIES NUMBER*

Threaded -  
 Socket Weld SW43211HF2  
 Trim: Monel

HYDROFLUORIC  
 ACID (HF)  
 ALKYLATION VALVES.  
 UOP APPROVED.

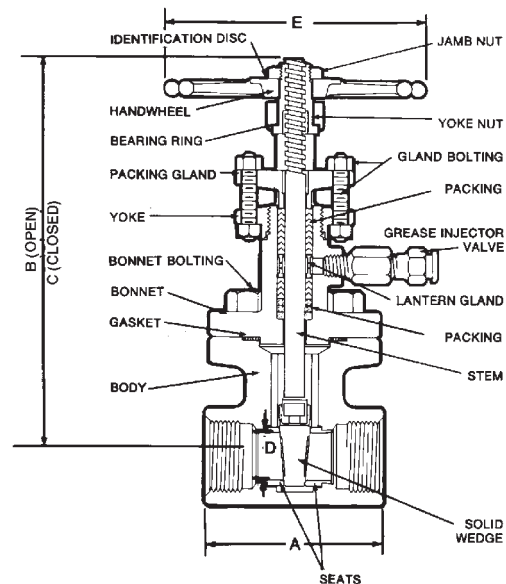

- Round Bolted Bonnet
- Spiral Wound Gasket
- Outside Screw & Yoke
- Bolted Gland
- Double Packing
- Lantern Ring
- Grease Injector
- Solid Wedge
- ASME B16.34

**Bold face numerals are in inches and pounds.**  
**Blue numerals are in millimeters and kilograms.**

## Dimensions

Size	NPS DN	42211MTG:					SW43211HF2:		
		1/2	3/4	1	1-1/2	2	1/2	3/4	1
<b>A-End-to-End</b>		3.38 86	3.38 86	4.00 102	4.75 121	5.25 133	3.38 86	4.00 102	4.38 111
<b>B-Open</b>		8.16 207	8.16 207	10.28 261	12.12 308	13.38 340	8.16 207	10.28 261	11.38 289
<b>C-Closed</b>		7.56 192	7.56 192	9.36 238	10.72 272	11.69 297	7.56 192	9.36 238	10.16 258
<b>D-Seat Diameter</b>		.50 12.7	.50 12.7	.75 19.1	1.25 31.8	1.50 38.1	.50 12.7	.75 19.1	1.00 25.4
<b>E-Handwheel Diameter</b>		4.00 102	4.00 102	4.75 121	5.75 146	7.00 178	4.00 102	4.75 121	5.75 146
<b>Weight</b>		5.4 2.5	5.8 2.6	9.8 4.4	17.6 8.0	23.0 10.4	5.8 2.6	9.8 4.4	17.6 8.0

+ Valves contain TEFLON—maximum temperature 500°F.  
 Refer to pages 116-120 for full materials description.

For Cv factors see page 123, Valve Matrix A.

For Cv factors see page 123, Valve Matrix B.

**GATE**  
**CLASS 800 (PN 130)**  
**42211MTG, 43211HF2**

## Forged Gate Valves For HF Alkylation Service

### Class 600 (PN 110)

Full Port

1480 PSI @ 100°F (102.1 BAR @ 38°C)

For other ratings see pgs. 112-115

A105 Body/Bonnet

SERIES NUMBER

Threaded      Socket Weld

43111MMP+      -

Trim: Monel

Listed in Phillips Petroleum  
Company's HF Alkylation  
Process Design Spec. Manual.

CLASS 600 (PN 110)  
43111MMP

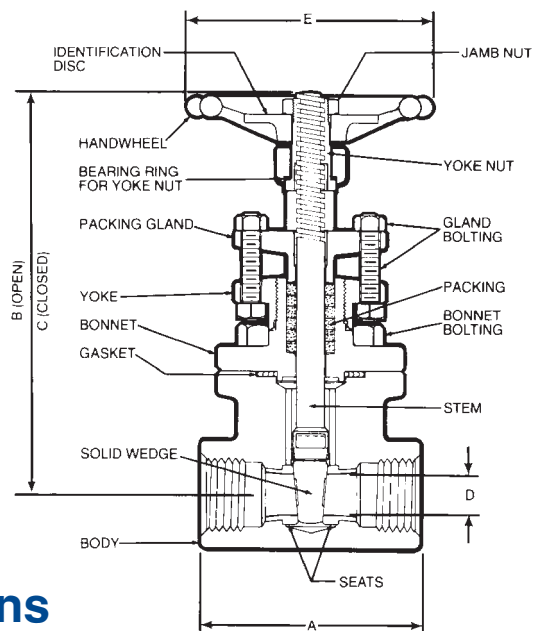

- Round Bolted Bonnet
- Spiral Wound Gasket
- Outside Screw & Yoke
- Bolted Gland
- Solid Wedge
- API 602
- ASME B16.34

### Dimensions

**Bold face numerals are in inches and pounds.**  
**Blue numerals are in millimeters and kilograms.**

Size	NPS DN	1/2 15	3/4 20	1 25
A-End-to-End		3.38 86	4.00 102	4.38 111
B-Open		6.38 162	8.31 211	9.56 243
C-Closed		5.75 146	7.38 187	8.38 213
D-Seat Diameter		.50 12.7	.75 19.1	1.00 25.4
E-Handwheel Diameter		4.00 102	4.75 121	5.75 146
Weight		5.0 2.3	8.3 3.8	12.1 5.5

\*Valves contain TEFLON — maximum temperature 500°F.  
Refer to pages 116-120 for full materials description.

For Cv factors see page 123, Valve Matrix B.

# Forged Gate Valves Bellowseal

## Class 800 (PN 130)

### Conventional Port

1975 PSI @ 100°F (136.2 BAR @ 38°C)

For other ratings see pgs. 112-115

### A105 Body/Bonnet

#### SERIES NUMBER

Threaded      Socket Weld  
**2801B**      **SW2801B**  
 Stem: 316  
 Bellows: 321SS  
 Wedge/Seats: HF

CLASS 800 (PN 130)  
2801B

- Welded Bonnet
- Outside Screw & Yoke
- Bolted Gland
- Seamless Multi-Ply Bellows
- Full Hard Faced
- ASME B16.34

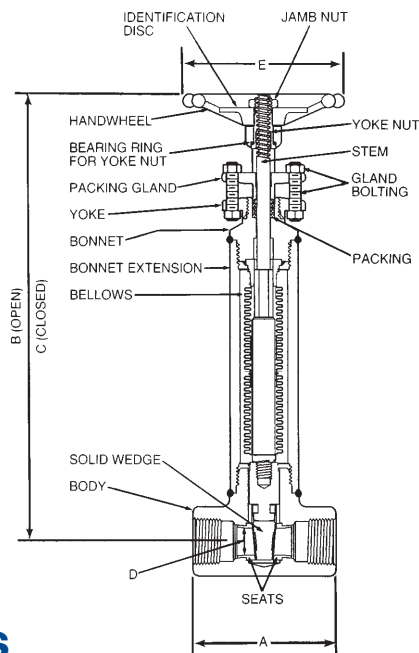

## Dimensions

**Bold face numerals are in inches and pounds.**  
**Blue numerals are in millimeters and kilograms.**

Size	NPS DN	1/2	3/4	1	1-1/2	2
A-End-to-End		3.38 86	3.38 86	4.00 102	5.25 133	5.25 133
B-Open		10.56 268	10.56 268	12.88 327	20.25 514	20.25 514
C-Closed		10.06 256	10.06 256	12.12 308	18.81 478	18.81 478
D-Seat Diameter		.50 12.7	.50 12.7	.75 19.1	1.50 38.1	1.50 38.1
E-Handwheel Diameter		4.00 102	4.00 102	4.75 121	7.00 178	7.00 178
Weight		4.2 1.9	8.8 4.0	8.5 3.9	28.3 12.8	27.8 12.6



## Forged Gate Valves

### Class 800 (PN 130) Conventional Port

1920 PSI @ 100°F (132.4 BAR @ 38°C)

For other ratings see pgs. 112-115

**SERIES NUMBER**

Body/Bonnet	Threaded	Socket Weld	THD/SW
F316/F316L	12401 12401T+	SW12401 SW12401T+	TSW12401
	12401FHF	SW12401FHF	Trim: 316 Wedge/Seats: HF
F316H	82401	SW82401	Sizes 1/2-2 (No 1-1/4) Trim: 316H Seats: HF
	82401FHF	SW82401	Sizes 1/2-2 (No 1-1/4) Trim: 316H Wedge/Seats: HF

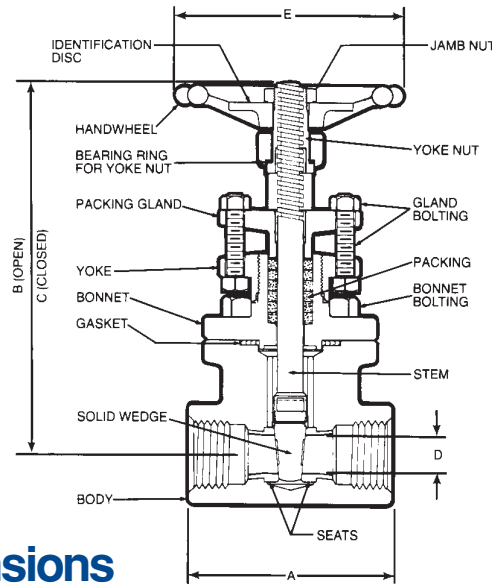

- Round Bolted Bonnet
- Spiral Wound Gasket
- Outside Screw & Yoke
- Bolted Gland
- Solid Wedge
- Hard Faced Seats
- API 602
- ASME B16.34

### Dimensions

**Bold face numerals are in inches and pounds.**  
**Blue numerals are in millimeters and kilograms.**

Size	NPS DN	1/4 8	3/8 10	1/2 15	3/4 20	1 25	1-1/4 32	1-1/2 40	2 50
A-End-to-End		2.75 70	2.75 70	3.38 86	3.38 86	4.00 102	4.75 121	4.75 121	5.25 133
B-Open		6.19 157	6.19 157	6.38 162	6.38 162	8.31 211	10.12 257	10.12 257	11.10 282
C-Closed		5.75 146	5.75 146	5.75 146	5.75 146	7.38 187	8.69 221	8.69 221	9.41 239
D-Seat Diameter		.31 7.9	.31 7.9	.50 12.7	.50 12.7	.75 19.1	1.25 31.8	1.25 31.8	1.50 38.1
E-Handwheel Diameter		4.00 102	4.00 102	4.00 102	4.00 102	4.75 121	5.75 146	5.75 146	7.00 178
Weight		4.9 2.2	4.8 2.2	5.0 2.3	4.9 2.2	8.3 3.8	16.6 7.5	16.0 7.3	21.8 9.9

+ Valves contain TEFLON—maximum temperature 500°F.  
Refer to pages 116-120 for full materials description.

For Cv factors see page 123, Valve Matrix A.

GATE  
CLASS 800 (PN 130)  
12401, 82401

## Forged Gate Valves

### Class 800 (PN 130)

#### Conventional Port

2000 PSI @ 100°F (137.9 BAR @ 38°C)

For other ratings see pgs. 112-115

*SERIES NUMBER*

Body/Bonnet	Threaded	Socket Weld
<b>F11, Cl. 2</b> (1-1/4% Cr.)	12321	<b>SW12321</b> Sizes 1/2-2 (No 1-1/4) <b>Trim: 13% Cr.</b> <b>Seats: HF</b>
	12321FHF	<b>SW12321FHF</b> Sizes 1/2-2 (No 1-1/4) <b>Trim: 13% Cr.</b> <b>Wedge/Seats: HF</b>
<b>F5</b> (5% Cr.)	12421	<b>SW12421</b> Sizes 1/2-2 (No 1-1/4) <b>Trim: 13% Cr.</b> <b>Seats: HF</b>
	12421FHF	<b>SW12421FHF</b> Sizes 1/2-2 (No 1-1/4) <b>Trim: 13% Cr.</b> <b>Wedge/Seats: HF</b>
<b>F9</b> (9% Cr.)	12921	<b>SW12921</b> Sizes 1/2-2 (No 1-1/4) <b>Trim: 13% Cr.</b> <b>Seats: HF</b>
	12921FHF	<b>SW12921FHF</b> Trim: 13% Cr. <b>Wedge/Seats: HF</b>
<b>F22, Cl. 3</b> (2-1/4% Cr.)	12521	<b>SW12521</b> Sizes 1/2-2 (No 1-1/4) <b>Trim: 13% Cr.</b> <b>Seats: HF</b>
	12521FHF	<b>SW12521FHF</b> Sizes 1/2-2 (No 1-1/4) <b>Trim: 13% Cr.</b> <b>Wedge/Seats: HF</b>

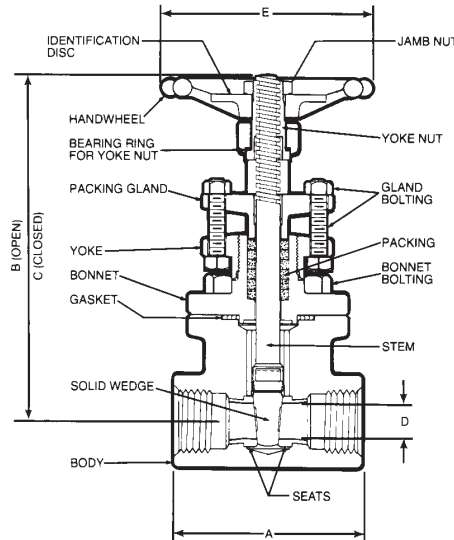

- Round Bolted Bonnet
- Spiral Wound Gasket
- Outside Screw & Yoke
- Bolted Gland
- Solid Wedge
- Hard Faced Seats
- API 602
- ASME B16.34

### Dimensions

**Bold face numerals are in inches and pounds.**  
**Blue numerals are in millimeters and kilograms.**

Size	NPS DN	1/4 8	3/8 10	1/2 15	3/4 20	1 25	1-1/4 32	1-1/2 40	2 50
<b>A-End-to-End</b>		2.75 70	2.75 70	3.38 86	3.38 86	4.00 102	4.75 121	4.75 121	5.25 133
<b>B-Open</b>		6.19 157	6.19 157	6.38 162	6.38 162	8.31 211	10.12 257	10.12 257	11.10 282
<b>C-Closed</b>		5.75 146	5.75 146	5.75 146	5.75 146	7.38 187	8.69 221	8.69 221	9.41 239
<b>D-Seat Diameter</b>		.31 7.9	.31 7.9	.50 12.7	.50 12.7	.75 19.1	1.25 31.8	1.25 31.8	1.50 38.1
<b>E-Handwheel Diameter</b>		4.00 102	4.00 102	4.00 102	4.00 102	4.75 121	5.75 146	5.75 146	7.00 178
<b>Weight</b>		4.9 2.2	4.8 2.2	5.0 2.3	4.9 2.2	8.3 3.8	16.6 7.5	16.0 7.3	21.8 9.9

Refer to pages 116-120 for full materials description.

For Cv factors see page 123, Valve Matrix A.

**GATE**  
**CLASS 800 (PN 130)**  
12321, 12421, 12921, 12521

# Forged Gate Valves – Cryogenic Service to -325°F (-198°C)

## Class 800 (PN 130)

### Conventional Port

1920 PSI @ 100°F (132.4 BAR @ 38°C)

1920 PSI @ -325°F (132.4 BAR @ -198°C)

For other ratings see pgs. 112-115

### F316/F316L Body/Bonnet

#### SERIES NUMBER

Threaded      Socket Weld  
**12401C+**      **SW12401C+**  
 Trim: 316  
 Seats: HF

## Dimensions

*Bold face numerals are in inches and pounds.  
 Blue numerals are in millimeters and kilograms.*

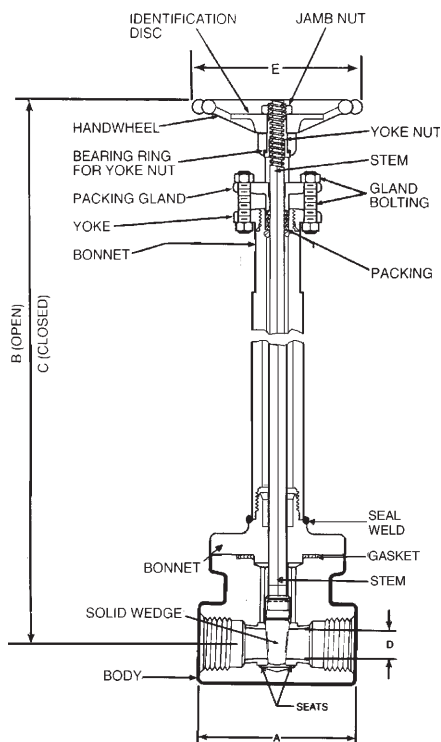

- Round Bolted Bonnet
- Spiral Wound Gasket
- Outside Screw & Yoke
- Bolted Gland
- Solid Wedge
- Hard Faced Seats
- Extended Bonnet
- ASME B16.34

Size	NPS DN	1/2 15	3/4 20	1 25	1-1/2 40	2 50
A-End-to-End		3.38	3.38	4.00	4.75	5.25
		86	86	102	121	133
B-Open		18.38	18.38	22.54	27.06	28.21
		467	467	573	687	717
C-Closed		17.75	17.75	21.62	25.84	26.52
		451	451	549	656	674
D-Seat Diameter		.50	.50	.75	1.25	1.50
		12.7	12.7	19.1	31.8	38.1
E-Handwheel Diameter		4.00	4.00	4.75	5.75	7.00
		102	102	121	146	178
Weight		6.6	6.9	11.3	19.6	25.8
		3.0	3.1	5.1	8.9	11.7

+ Valves contain TEFLON—maximum temperature 500°F.  
 Refer to pages 116-120 for full materials description.

For Cv factors see page 123, Valve Matrix A.

**GATE**  
**CLASS 800 (PN 130)**  
**12401C**

**Forged Gate Valves – ASTM A350, Grade LF2 for Temperatures to -50°F (-46°C)**

**Class 800 (PN 130)**  
Conventional Port

1975 PSI @ 100°F (136.2 BAR @ 38°C)  
1975 PSI @ -50°F (136.2 BAR @ -46°C)

For other ratings see pgs. 112-115

A350, Gr. LF2 Body/Bonnet

Threaded 32111	<i>SERIES NUMBER</i> Socket Weld SW32111 Trim: 13% Cr. Seats: HF	THD/SW TSW32111
32111F8M	SW32111F8M Trim: 316 Seats: HF	TSW32111F8M
32111MB8	SW32111MB8 Trim: 316 Wedge/Seats: HF	
32111MM	SW32111MM Trim: Monel	

GATE CLASS 800 (PN 130) 32111

MATERIALS MEET REQUIREMENTS OF NACE STANDARD MR-01-75 FOR SOUR SERVICE

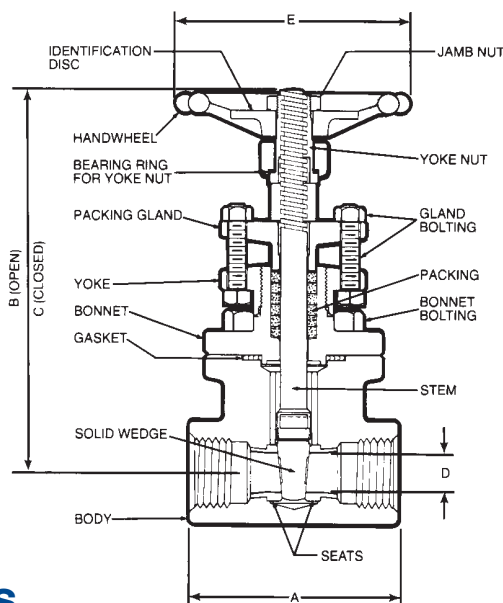

- Round Bolted Bonnet
- Spiral Wound Gasket
- Outside Screw & Yoke
- Bolted Gland
- Solid Wedge
- Hard Faced Seats
- API 602
- ASME B16.34

**Dimensions**

*Bold face numerals are in inches and pounds.  
Blue numerals are in millimeters and kilograms.*

Size	NPS DN	1/2 15	3/4 20	1 25	1-1/2 40	2 50
A-End-to-End		3.38 86	3.38 86	4.00 102	4.75 121	5.25 133
B-Open		6.38 162	6.38 162	8.31 211	10.12 257	11.10 282
C-Closed		5.75 146	5.75 146	7.38 187	8.69 221	9.41 239
D-Seat Diameter		.50 12.7	.50 12.7	.75 19.1	1.25 31.8	1.50 38.1
E-Handwheel Diameter		4.00 102	4.00 102	4.75 121	5.75 146	7.00 178
Weight		5.0 2.3	4.9 2.2	8.3 3.8	16.0 7.3	21.8 9.9

Refer to pages 116-120 for full materials description.

For Cv factors see page 123, Valve Matrix A.

# Forged Gate Valves – Emission Reduction (Including Retrofit Bonnet Assembly)

## Class 800 (PN 130)

### Conventional Port

1975 PSI @ 100°F  
(136.2 BAR @ 38°C)\*

For other ratings see pgs. 112-115

### A105 Body/Bonnet

#### SERIES NUMBER

Threaded	Socket Weld
12111ER	SW12111ER
	Trim: 13% Cr.
	Seats: HF

**EMISSIONS REDUCTION  
RETROFIT BONNET ASSEMBLY PACKAGES**  
for Field Retrofitting of Vogt Series Nos. 353,  
363, 373, 12111, SW12111, 12161 and SW12161

**GATE**  
**CLASS 800 (PN 130)**  
**12111ER, 41000**

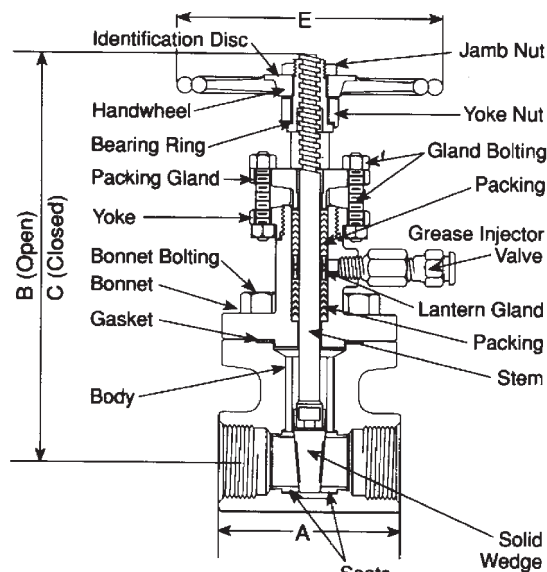

- Round Bolted Bonnet
- Spiral Wound Gasket
- Outside Screw & Yoke
- Bolted Gland
- Double Packing
- Lantern Ring
- Sealant Injector
- Solid Wedge
- Hard Faced Seats
- API 602
- ASME B16.34

**Bold face numerals are in inches and pounds.**  
**Blue numerals are in millimeters and kilograms.**

## Dimensions

Size	NPS DN	1/2 15	3/4 20	1 25	1-1/4 32	1-1/2 40	2 50
A-End-to-End		3.38 86	3.38 86	4.00 102	4.75 121	4.75 121	5.25 133
B-Open		8.16 207	8.16 207	10.28 261	12.12 308	12.12 308	13.38 340
C-Closed		7.56 192	7.56 192	9.36 238	10.72 272	10.72 272	11.69 297
D-Seat Diameter		.50 12.7	.50 12.7	.75 19.1	1.25 31.8	1.25 31.8	1.50 38.1
E-Handwheel Diameter		4.00 102	4.00 102	4.75 121	5.75 146	5.75 146	7.00 178
Weight		5.9 2.7	5.8 2.6	9.8 4.4	17.7 8.0	17.6 8.0	23 10.4

Refer to pages 116-120 for full materials description.

For Cv factors see page 123, Valve Matrix A.

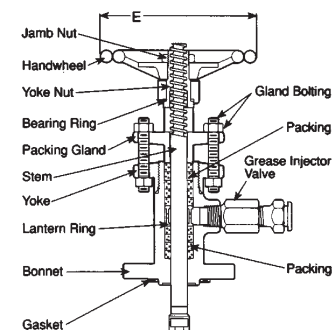

Order by this number: ↓

Valve Size (Series above)	Retrofit Bonnet Assembly Pkg. No.
1/2, 3/4	41000 04
1	41000 06
1-1/4, 1-1/2	41000 08
2	41000 09

\*Service temperature will be limited by sealant manufacturer's recommendation.

## Forged Gate Valves – Flexial Design

**Zero Fugitive Emissions**  
 Temperature to 425°F (218°C)  
**A105 Body/Bonnet**

For other ratings see pgs. 112-115

### Class 150 (PN 20) Conventional Port

285 PSI @ 100°F  
 (19.7 BAR @ 38°C)

*SERIES NUMBER*

353R Size 3"

BW 353R Sizes 2-1/2", 3"

Trim: Hastelloy Stem & Bellows  
 Wedge/Seats: HF

### Class 300 (PN 50) Conventional Port

740 PSI @ 100°F  
 (51 BAR @ 38°C)

*SERIES NUMBER*

363R Size 3"

BW 363R Sizes 2-1/2", 3"

Trim: Hastelloy Stem & Bellows  
 Wedge/Seats: HF

### Class 600 (PN 110) Conventional Port

1480 PSI @ 100°F  
 (102.1 BAR @ 38°C)

*SERIES NUMBER*

373R Size 3"

BW 373R Sizes 2-1/2", 3"

Trim: Hastelloy Stem & Bellows  
 Wedge/Seats: HF

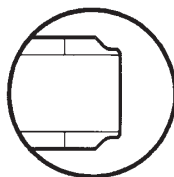

**Butt Weld Ends**  
 Schedule 40  
 For Class 150 and 300  
 Schedule 80  
 For Class 600

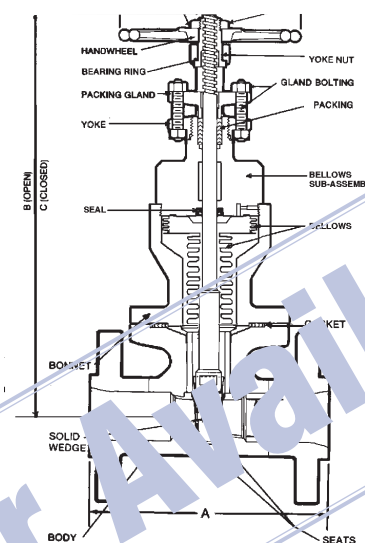

- Round Bolted Bonnet
- Spiral Wound Gasket
- Outside Screw & Yoke
- Round Flange
- Solid Wedge
- Full-Faced Seats
- ASME B16.34
- Five Year Limited Warranty
- Compact Bellows Design

Flanged Ends, Class 150 & 300 1/16" R.F.  
 Flanged Ends, Class 600 1/4" R.F.

*Bold face numerals are in inches and pounds.  
 Blue numerals are in millimeters and kilograms.*

### Dimensions

		353R	363R	373R	BW 353R/363R	BW 373R
Size	NPS DN	3 80	3 80	3 80	2-1/2 65	3 80
A-End to End		8.00 203	11.12 282	14.00 356	9.50 241	11.12 282
B-Open		19.84 504	19.84 504	19.84 504	19.84 504	19.84 504
C-Closed		17.59 447	17.59 447	17.59 447	17.59 447	17.59 447
D-Seat Diameter		2.00 50.8	2.00 50.8	2.00 50.8	2.00 50.8	2.00 50.8
E-Handwheel Diameter		8.00 203	8.00 203	8.00 203	8.00 203	8.00 203
Weight		72.4 32.9	82.5 37.4	98.5 44.7	49.2 22.3	59.2 26.9

Valve flanges conform to ASME Standard B16.5 and end-to-end dimensions conform to ASME Standard B16.10.

For Cv factors see page 123, Valve Matrix A.  
 Refer to pages 116-120 for full materials description.

## Forged Gate Valves

### Class 800 (PN 130)

Full Port

1975 PSI @ 100°F (136.2 BAR @ 38°C)

For other ratings see pgs. 112-115

Body/Bonnet	SERIES NUMBER	Socket Weld
A105	13111	SW13111 Trim: 13% Cr. Seats: HF
	13111FHF	SW13111FHF Trim: 13% Cr. Wedge/Seats: HF
	13111F8M	SW13111F8M Trim: 316 Seats: HF
	13111MB8	SW13111MB8 Trim: 316 Wedge/Seats: HF
	13111MM	SW13111MM SW13111HF4 SW13111HF5 Trim: Monel

1920 PSI @ 100°F (132.4 BAR @ 38°C)

F316/F316L	13401	SW13401 Trim: 316 Seats: HF
------------	-------	-----------------------------------

MATERIALS MEET REQUIREMENTS OF NACE STANDARD MR-01-75 FOR SOUR SERVICE

HYDROFLUORIC ACID (HF) ALKYLATION VALVES. UOP APPROVED.

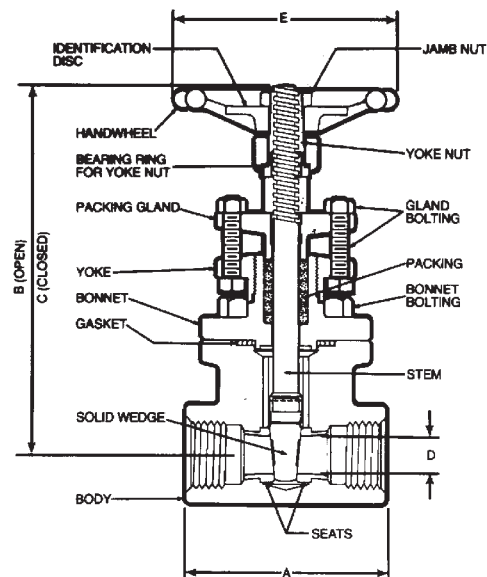

- Round Bolted Bonnet
- Spiral Wound Gasket
- Outside Screw & Yoke
- Bolted Gland
- Solid Wedge
- Hard Faced Seats
- API 602
- ASME B16.34

### Dimensions

**Bold face numerals are in inches and pounds.**  
**Blue numerals are in millimeters and kilograms.**

Size	NPS DN	1/2 15	3/4 20	1 25	1-1/2 40	2 50
A-End-to-End		3.38	4.00	4.38	5.25	7.00
		86	102	111	133	178
B-Open		6.38	8.31	9.56	11.10	14.09
		162	211	243	282	358
C-Closed		5.75	7.38	8.38	9.41	11.81
		146	187	213	239	300
D-Seat Diameter		.50	.75	1.00	1.50	2.00
		12.7	19.1	25.4	38.1	50.8
E-Handwheel Diameter		4.00	4.75	5.75	7.00	8.00
		102	121	146	178	203
Weight		5.0	8.3	12.1	22.8	42.8
		2.3	3.8	5.5	10.4	19.4

Refer to pages 116-120 for full materials description.

For Cv factors see page 123, Valve Matrix B.

## Forged Gate Valves – Flexial Design

Zero Fugitive Emissions

Temperature to 425°F (218°C)

**A105 Body/Bonnet**

1975 PSI @ 100°F (136.2 BAR @ 38°C)

For other ratings see pgs. 112-115

### Class 800 (PN 130)

*SERIES NUMBER*

Threaded	Socket Weld
12111R	SW12111R
13111R	SW13111R (Full Port)
	Trim: Hastelloy Stem & Bellows
	Wedge/Seats: HF

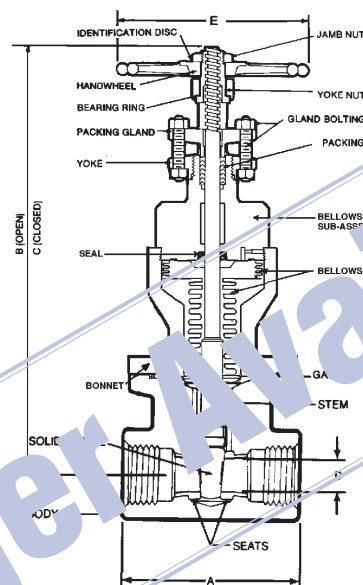

- Round Bolted Bonnet
- Spiral Wound Gasket
- Outside Screw & Yoke
- Bolted Gland
- Stem Seal
- Full Face Seats
- ASME B16.34
- Five Year Limited Warranty
- Compact Bellows Design

*Bold face numerals are in inches and pounds.  
Blue numerals are in millimeters and kilograms.*

### Dimensions

		12111R	13111R
Size	NPS DN	2-1/2 65	2 50
A-End-to-End		7.00 178	7.00 178
B-Open		19.84 504	19.84 504
C-Closed		17.59 447	17.59 447
D-Seat Diameter		2.00 50.8	2.00 50.8
E-Handwheel Diameter		8.00 203	8.00 203
Weight		57.8 26.2	57.8 26.2

Refer to pages 116-120 for full materials description.

For Cv factors see page 123, Valve Matrix A or B, as applicable.

## Forged Gate Valves

### Class 800 (PN 130)

#### Conventional Port

1975 PSI @ 100°F  
(136.2 BAR @ 38°C)

For other ratings see pgs. 112-115

#### A105 Body/Bonnet

##### SERIES NUMBER

Threaded	Socket Weld
12161	SW12161 Trim: 13% Cr. Seats: HF
12161F8M	SW12161F8M Trim: 316 Seats: HF
12161MM	SW12161MM Trim: Monel

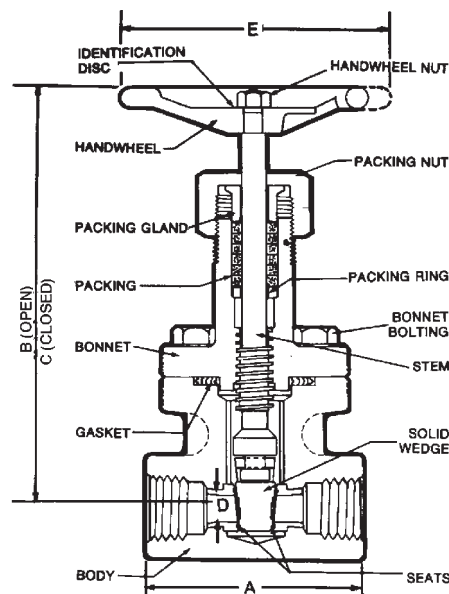

- Round Bolted Bonnet
- Spiral Wound Gasket
- Inside Screw Stem
- Screw Gland
- Solid Wedge
- Hard Faced Seats
- API 602
- ASME B16.34

### Dimensions

**Bold face numerals are in inches and pounds.**  
**Blue numerals are in millimeters and kilograms.**

Size	NPS DN	1/4 8	3/8 10	1/2 15	3/4 20	1 25	1-1/4 32	1-1/2 40	2 50
A-End-to-End		2.75	2.75	3.38	3.38	4.00	4.75	4.75	5.25
		70	70	70	86	102	121	121	133
B-Open		6.44	6.44	6.44	6.44	8.31	10.75	10.75	12.25
		164	164	164	164	211	273	273	311
C-Closed		5.88	5.88	5.88	5.88	7.38	9.38	9.38	10.56
		149	149	149	149	187	238	238	268
D-Seat Diameter		.31	.31	.50	.50	.75	1.25	1.25	1.50
		7.9	7.9	12.7	12.7	19.1	31.8	31.8	38.1
E-Handwheel Diameter		4.00	4.00	4.00	4.00	4.75	5.75	5.75	7.00
		102	102	102	102	121	146	146	178
Weight		4.3	4.3	4.8	4.7	7.9	16.4	16.1	23.6
		2.0	2.0	2.2	2.1	3.6	7.4	7.3	10.7

# Forged Gate Valves

## Class 800 (PN 130)

### Conventional Port

1975 PSI @ 100°F (136.2 BAR @ 38°C)

For other ratings see pgs. 112-115

### A105 Body/Bonnet

Threaded <b>2801</b>	<i>SERIES NUMBER</i> Socket Weld <b>SW2801</b> Trim: 13% Cr. Seats: HF	THD/SW <b>TSW2801</b>
<b>2801MM</b>	<b>SW2801MM</b> Trim: Monel	
<b>2801FHF</b> <b>2801MB6</b>	<b>SW2801FHF</b> <b>SW2801MB6</b> Trim: 13% Cr. Wedge/Seats: HF	<b>TSW2801FHF</b>
<b>2801F8M</b>	<b>SW2801F8M</b> Trim: 316 Seats: HF	
<b>2801MBS</b>	<b>SW2801MBS</b> Trim: Monel Wedge: HF	
<b>2801MB8</b>	<b>SW2801MB8</b> Trim: 316 Wedge/Seats: HF	

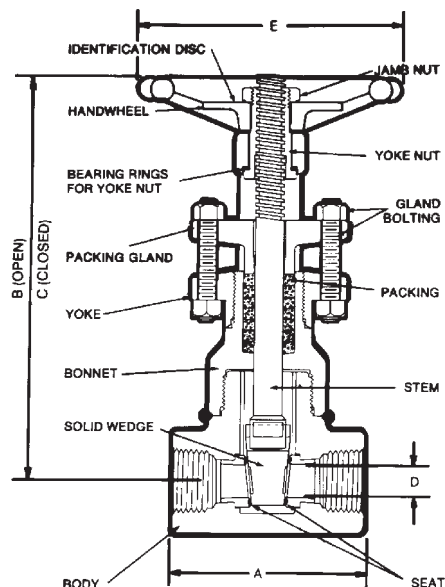

- Welded Bonnet
- Outside Screw & Yoke
- Bolted Gland
- Solid Wedge
- Hard Faced Seats
- API 602
- ASME B16.34

## Dimensions

*Bold face numerals are in inches and pounds.  
Blue numerals are in millimeters and kilograms.*

Size	NPS DN	1/4 8	3/8 10	1/2 15	3/4 20	1 25	1-1/4 32	1-1/2 40	2 50
A-End-to-End		2.75 70	2.75 70	3.38 86	3.38 86	4.00 102	4.75 121	4.75 121	5.25 133
B-Open		6.34 161	6.34 161	6.50 165	6.50 165	8.31 236	10.12 257	10.12 257	11.10 282
C-Closed		5.88 149	5.88 149	5.88 149	5.88 149	7.38 187	8.69 221	8.69 221	9.41 239
D-Seat Diameter		.31 7.9	.31 7.9	.50 12.7	.50 12.7	.75 19.1	1.25 31.8	1.25 31.8	1.50 38.1
E-Handwheel Diameter		4.00 102	4.00 102	4.00 102	4.00 102	4.75 121	5.75 146	5.75 146	7.00 178
Weight		3.0 1.4	3.0 1.4	3.5 1.6	3.4 1.5	6.2 2.8	11.5 5.2	10.9 4.9	16.0 7.3

Refer to pages 116-120 for full materials description.

For Cv factors see page 123, Valve Matrix A.

MATERIALS MEET REQUIREMENTS OF NACE STANDARD MR-01-75 FOR SOUR SERVICE

# Forged Gate Valves – Extended Body Valves

## Class 800 (PN 130)

### Conventional Port

For other ratings see pgs. 112-115

#### A105 BODY/BONNET

1975 PSI @ 100°F (136.2 BAR @ 38°C)

**SERIES NUMBER**  
 CT 2801 Trim: 13% Cr.  
 Seats: HF

**TYPE ENDS**

Integral Male  
 Couplet  
 Female  
 Threaded

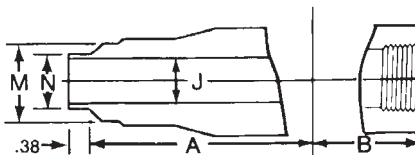

#### F316, F316L BODY/BONNET

1920 PSI @ 100°F  
 (132.4 BAR @ 38°C)

**SERIES NUMBER**  
 CT 2831 Trim: 316  
 Seats: HF

#### A105 BODY/BONNET

1975 PSI @ 100°F (136.2 BAR @ 38°C)

**SERIES NUMBER**  
 CT 2901 Trim: 13% Cr.  
 Seats: HF  
 CS 2901 Trim: 13% Cr.  
 Seats: HF  
 CT 2911\* Trim: 13% Cr.  
 Seats: HF

**TYPE ENDS**

Integrally Reinforced  
 Extended Length  
 Male Couplet  
 Female Socket Weld

BT 2901 Trim: 13% Cr.  
 Seats: HF  
 BT 2901MB6 Trim: 13% Cr  
 Wedge/  
 Seats: HF

Integrally Reinforced  
 Extended Length  
 Butt Weld End  
 Female Threaded

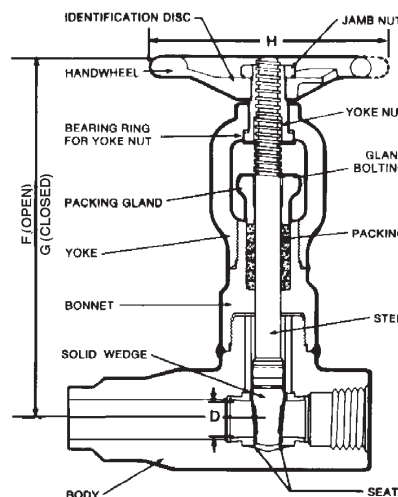
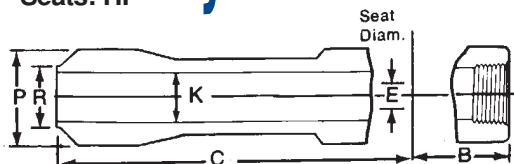

- Welded Bonnet
- Outside Screw & Yoke
- Bolted Gland
- Solid Wedge
- Hard Faced Seats
- API 602
- ASME B16.34

## Dimensions

Size	NPS DN	1/2 15	3/4 20	1 25	1-1/2 40
A		4.00 <b>102</b>	4.00 <b>102</b>	4.38 <b>111</b>	5.00 <b>127</b>
B		1.69 <b>73</b>	1.69 <b>73</b>	2.00 <b>51</b>	2.38 <b>60</b>
C		7.00 <b>178</b>	7.00 <b>178</b>	7.50 <b>190</b>	8.00 <b>203</b>
D		.47 <b>11.9</b>	.47 <b>11.9</b>	.69 <b>17.5</b>	1.25 <b>31.8</b>
E		.50 <b>12.7</b>	.50 <b>12.7</b>	.75 <b>19.1</b>	1.25 <b>31.8</b>
F		6.50 <b>165</b>	6.50 <b>165</b>	8.31 <b>236</b>	10.12 <b>257</b>
G		5.88 <b>149</b>	5.88 <b>149</b>	7.38 <b>187</b>	8.69 <b>221</b>
H		4.00 <b>102</b>	4.00 <b>102</b>	4.75 <b>121</b>	5.75 <b>146</b>
J		.64 <b>16.3</b>	.65 <b>16.5</b>	.90 <b>22.9</b>	1.47 <b>37.3</b>
K		.75 <b>19.0</b>	.75 <b>19.0</b>	1.00 <b>25.4</b>	1.50 <b>38.1</b>
M		1.25 <b>31.8</b>	1.25 <b>31.8</b>	1.56 <b>39.6</b>	2.25 <b>57.2</b>
N		.81 <b>20.6</b>	.81 <b>20.6</b>	1.06 <b>26.9</b>	1.69 <b>42.9</b>
P		1.56 <b>39.6</b>	1.56 <b>39.6</b>	1.94 <b>49.7</b>	2.56 <b>65.0</b>
R		.97 <b>24.6</b>	.97 <b>24.6</b>	1.22 <b>37.8</b>	1.72 <b>43.7</b>
Weight (Approx.)		4.4 <b>2.0</b>	4.1 <b>1.9</b>	7.3 <b>3.3</b>	12.8 <b>5.8</b>

**Bold face numerals are in inches and pounds.**  
**Blue numerals are in millimeters and kilograms.**

Refer to Pages 116-120 for full materials description.  
 For Cv factors see Page 123 Value Matrix E.

\*Inside Screw Stem valves are not illustrated above; however, OS&Y dimensions shown are applicable, except for the open/closed dimensions which exceed those shown.

MATERIALS MEET  
 REQUIREMENTS OF  
 NACE STANDARD  
 MR-01-75 FOR  
 SOUR SERVICE

# Forged Gate Valves – Extended Body Valves

## Class 800 (PN 130)

### Conventional Port

For other ratings see pgs. 112-115

#### A105 BODY/BONNET

1975 PSI @ 100°F (136.2 BAR @ 38°C)

##### SERIES NUMBER

TT 2801	Trim: 13% Cr. Seat: HF
TT 2801MM	Trim: Monel
TT 2801F8M	Trim: 316 Seats: HF
TT 2801MB8	Trim: 316 Wedge/Seats: HF
TT 2801MB6	Trim: 13% Cr. Wedge/Seats: HF
TT 2811*	Trim: 13% Cr. Seat: HF

##### TYPE ENDS

Integral Male  
Threaded  
Female  
Threaded

MATERIALS MEET  
REQUIREMENTS  
OF NACE  
STANDARD  
MR-01-75 FOR  
SOUR SERVICE

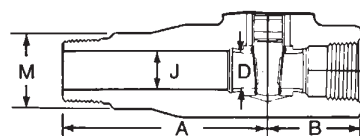

#### F316/F316L BODY/BONNET

1920 PSI @ 100°F  
(132.4 BAR @ 38°C)

TT 2831	Trim: 316 Seat: HF
---------	-----------------------

#### A105 BODY/BONNET

1975 PSI @ 100°F (136.2 BAR @ 38°C)

##### SERIES NUMBER

ST 2801	Trim: 13% Cr. Seats: HF
ST 2801F8M	Trim: 316 Seats: HF
ST 2801MM	Trim: Monel
ST 2801FHF	Trim: 13% Cr. Wedge/Seats: HF
ST 2801MB8	Trim: 316 Wedge/Seats: HF
ST 2801MB6	Trim: 13% Cr. Wedge/Seats: HF
SS 2801	Trim: 13% Cr. Seats: HF
SS 2801MB6	Trim: 13% Cr. Wedge/Seats: HF

##### TYPE ENDS

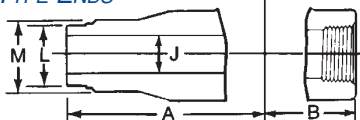

Integral Male Socket  
Weld  
Female  
Threaded

Integral Male Socket  
Weld Female Socket  
Weld (Not illus.)

MATERIALS MEET REQUIREMENTS  
OF NACE STANDARD MR-01-75  
FOR SOUR SERVICE

#### F316/F316L BODY/BONNET

1920 PSI @ 100°F  
(132.4 BAR @ 38°C)

ST 2831	Trim: 316 Seats: HF
---------	------------------------

Integral Male Socket  
Weld Female Threaded  
(See above illus.)

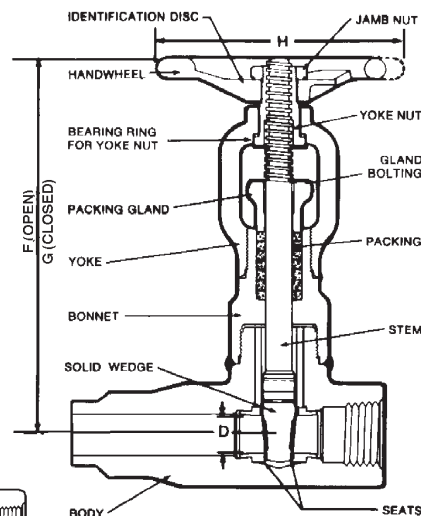

- Welded Bonnet
- Outside Screw & Yoke
- Bolted Gland
- Solid Wedge
- Hard Faced Seats
- API 602
- ASME B16.34

## Dimensions

Size	NPS DN	1/2 15	3/4 20	1 25	1-1/2 40
A		4.00 102	4.00 102	4.38 111	5.00 127
B		1.69 73	1.69 73	2.00 51	2.38 60
D		.47 11.9	.47 11.9	.69 17.5	1.25 31.8
F		6.50 165	6.50 165	8.31 236	10.12 257
G		5.88 149	5.88 149	7.38 187	8.69 221
H		4.00 102	4.00 102	4.75 121	5.75 146
J		.64 16.3	.65 16.5	.90 22.9	1.47 37.3
L		.84 21.3	1.05 26.7	1.32 33.5	1.90 48.3
M		1.25 31.8	1.25 31.8	1.56 39.6	2.25 57.2
Weight (Approx.)		4.4 2.0	4.1 1.9	7.3 3.3	12.8 5.8

**Bold face numerals are in inches and pounds.**  
**Blue numerals are in millimeters and kilograms.**

Refer to Pages 116-120 for full materials description.

For Cv factors see Page 123 Value Matrix E.

\***Inside Screw Stem valves** are not illustrated above; however, OS&Y dimensions shown are applicable, except for the open/closed dimensions which exceed those shown.

1/2" TT 2801, TT 2811 and TT 2831 male threaded valves are not covered under API 602 rules.

# Forged Gate Valves – Extended Body Valves

## Class 800 (PN 130)

### Conventional Port

For other ratings see pgs. 112-115

### A105 Body/Bonnet

1975 PSI @ 100°F (136.2 BAR @ 38°C)

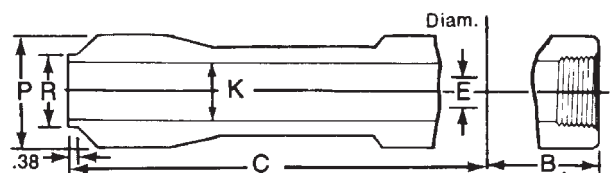

**SERIES NUMBER**  
 CT 12111 Trim: 13% Cr. Seats: HF  
 CT 12111MB8 Trim: 316 Wedge/Seats: HF

**TYPE ENDS**  
 Integrally Reinforced Extended Length Male Couplet Female Threaded

MATERIALS MEET REQUIREMENTS OF NACE STANDARD MR-01-75 FOR SOUR SERVICE

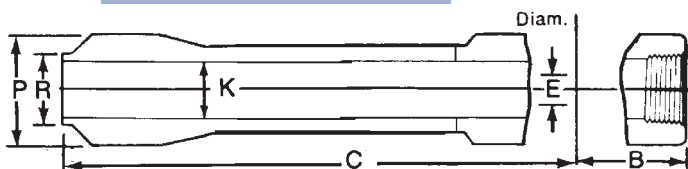

**SERIES NUMBER**  
 BT 12111 Trim: 13% Cr. Seats: HF  
 BT 12111MB8 Trim: 316 Wedge/Seats: HF

**TYPE ENDS**  
 Integrally Reinforced Extended Length Male Butt Weld Couplet Female Threaded

**SERIES NUMBER**  
 BS 12111 Trim: 13% Cr. Seats: HF

**TYPE ENDS**  
 Integrally Reinforced Extended Length Male Butt Weld Couplet Female Socket Weld (not illustrated)

MATERIALS MEET REQUIREMENTS OF NACE STANDARD MR-01-75 FOR SOUR SERVICE

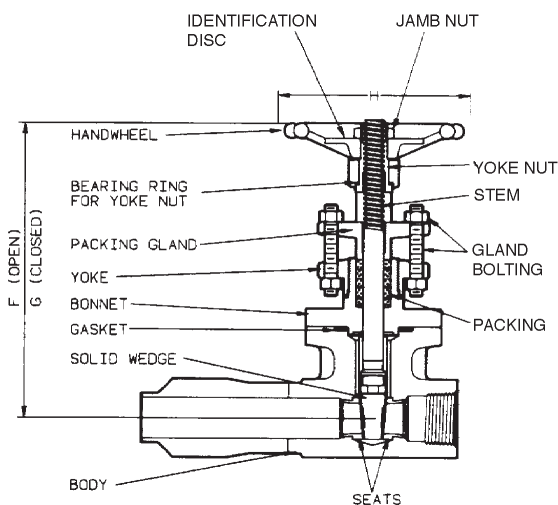

- Bolted Bonnet
- Outside Screw & Yoke
- Bolted Gland
- Solid Wedge
- Hard Faced Seats
- API 602
- ASME B16.34

## Dimensions

Size	NPS DN	1/2 15	3/4 20	1 25	1-1/2 40
B		1.97 50	1.97 50	2.09 53	2.72 69
C		7.00 178	7.00 178	7.50 190	8.00 203
E		.50 12.7	.50 12.7	.75 19.1	1.25 31.8
F		6.38 162	6.38 162	8.31 236	10.12 257
G		5.75 146	5.75 146	7.38 187	8.69 221
H		4.00 102	4.00 102	4.75 121	5.75 146
K		.75 19.1	.75 19.1	1.00 25.4	1.50 38.1
P		1.56 39.6	1.56 39.6	1.94 49.7	2.56 65.0
R		.97 24.6	.97 24.6	1.22 37.8	1.72 43.7
Weight (Approx.)		6.0 2.7	5.6 2.5	9.4 4.3	16.5 7.5

**Bold face numerals are in inches and pounds.**  
**Blue numerals are in millimeters and kilograms.**

Refer to Pages 116-120 for full materials description. For Cv factors see Page 123 Value Matrix F.  
 Can be disassembled for post weld heat treat procedure after installation if gate orientation is marked and maintained in same valve when reassembled.  
 Note: The valves illustrated on this page do not require an interfacing fitting. The valve can be welded directly to a pipe header or vessel. Valve designs similar to the above are available without the 0.38" integral backing ring.

GATE CLASS 800 (PN 130) CT 12111, BT 12111, BS 12111

# Forged Gate Valves – Extended Body Valves

## Class 800 (PN 130)

### Conventional Port

For other ratings see pgs. 112-115

#### A105 Body/Bonnet

1975 PSI @ 100°F (136.2 BAR @ 38°C)

- Bolted Bonnet
- Outside Screw & Yoke
- Bolted Gland
- Solid Wedge
- Hard Faced Seats
- API 602
- ASME B16.34

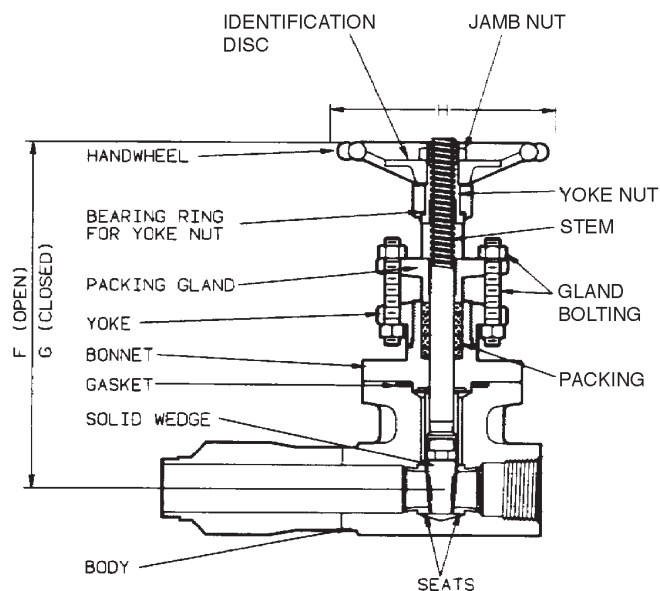

## Dimensions

Size	NPS DN	1/2 15	3/4 20	1 25	1-1/2 40
A		6.50 165	7.00 178	7.50 191	8.00 203
B		1.97 50	1.97 50	2.09 53	2.72 69
D		.47 11.9	.47 11.9	.75 19.1	1.25 31.8
F		6.38 162	6.38 162	8.31 211	10.12 257
G		5.75 146	5.75 146	7.38 187	8.69 221
H		4.00 102	4.00 102	4.75 121	5.75 146
J		.64 16.3	.75 19.1	1.00 25.4	1.50 38.1
L		.84 21	1.05 26.7	1.32 34	1.90 48
M		1.56 39.6	1.56 39.6	1.94 49.7	2.56 65.0
Weight (Approx.)		5.7 2.6	4.1 1.9	7.3 3.3	16.5 7.5

**Bold face numerals are in inches and pounds.**  
**Blue numerals are in millimeters and kilograms.**

Refer to Pages 116-120 for full materials description. For Cv factors see Page 123 Valve Matrix F.  
 Can be disassembled for post weld heat treat procedure after installation if gate orientation is marked and maintained in same valve when reassembled.

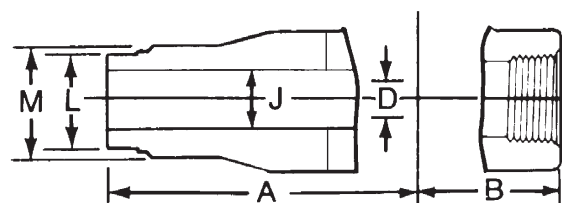

MATERIALS MEET REQUIREMENTS OF NACE STANDARD MR-01-75 FOR SOUR SERVICE

SERIES NUMBER		Type Ends
ST 12111	Trim: 13% Cr. Seats: HF	} Integral Male Socket Weld Female Threaded
ST 12111MB8	Trim: 316 Wedge/Seats: HF	
ST 12111MB6	Trim: 13% Cr. Wedge/Seats: HF	

# Forged Gate Valves – Extended Body Valves

## Class 800 (PN 130)

### Conventional Port

For other ratings see pgs. 112-115

#### A105 Body/Bonnet

1975 PSI @ 100°F (136.2 BAR @ 38°C)

GATE CLASS 800 (PN 130) TT12111

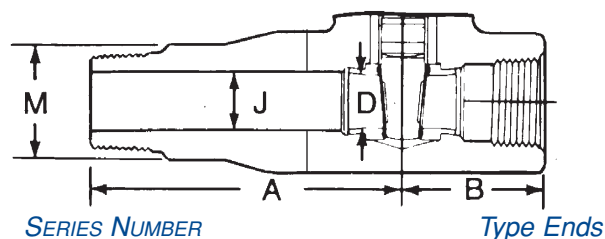

SERIES NUMBER	Trim	Seats
TT 12111	13% Cr.	HF
TT 12111FHF	13% Cr. Wedge/Seats	HF
TT 12111MB8	316 Wedge/Seats	HF
TT 12111MB6	13% Cr. Wedge/Seats	HF

Male Threaded  
Female Threaded

MATERIALS MEET REQUIREMENTS OF NACE STANDARD MR-01-75 FOR SOUR SERVICE

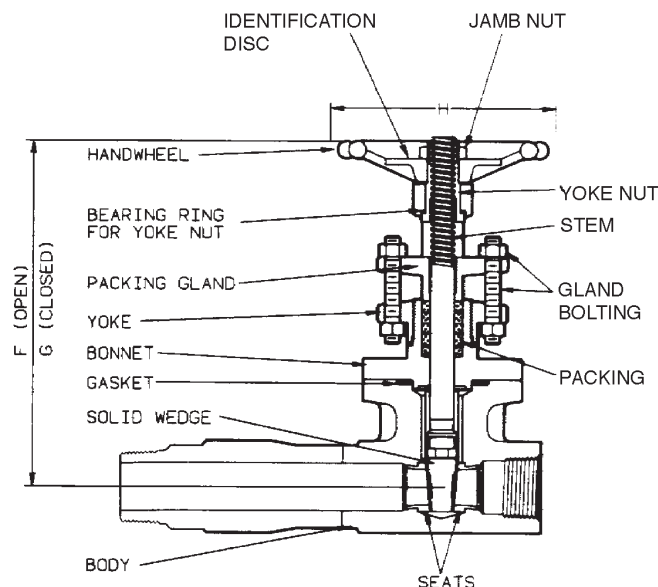

- Bolted Bonnet
- Outside Screw & Yoke
- Bolted Gland
- Solid Wedge
- Hard Faced Seats
- API 602
- ASME B16.34

## Dimensions

Size	NPS DN	1/2 15	3/4 20	1 25	1-1/2 40
A		4.50 114	4.50 114	5.25 133	6.00 152
B		1.97 50	1.97 50	2.09 53	2.72 69
D		.41 10.4	.47 11.9	.69 17.5	1.25 31.8
F		6.38 162	6.38 162	8.31 211	10.12 257
G		5.75 146	5.75 146	7.38 187	8.69 221
H		4.00 102	4.00 102	4.75 121	5.75 146
J		.52 13.2	.64 16.3	.89 22.6	1.47 37.3
M		1.56 39.6	1.56 39.6	1.94 49.7	2.56 65.0
Weight		5.7 2.6	4.1 1.9	7.3 3.3	16.5 7.5

**Bold face numerals are in inches and pounds.**  
**Blue numerals are in millimeters and kilograms.**

Refer to Pages 116-120 for full materials description. For Cv factors see Page 123 Valve Matrix F.  
Can be disassembled for post weld heat treat procedure after installation if gate orientation is marked and maintained in same valve when reassembled.

## Forged Gate Valves

### Class 800 (PN 130)

#### Conventional Port

1920 PSI @ 100°F  
(132.4 BAR @ 38°C)

For other ratings see pgs. 112-115

#### F316/F316L Body/Bonnet

##### SERIES NUMBER

Threaded	Socket Weld
2831	SW 2831
2831T+	SW 2831T+
	Trim: 316
	Seats: HF

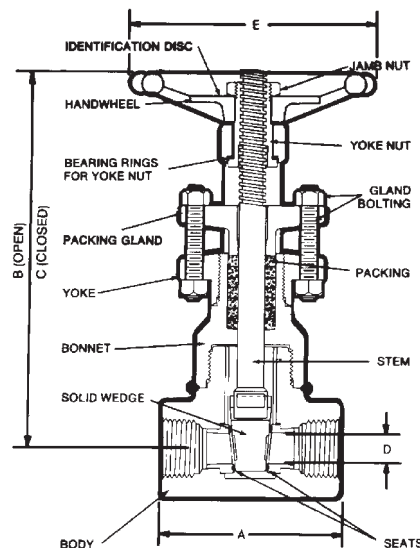

- Welded Bonnet
- Outside Screw & Yoke
- Bolted Gland
- Solid Wedge
- Hard Faced Seats
- API 602
- ASME B16.34

### Dimensions

**Bold face numerals are in inches and pounds.**  
**Blue numerals are in millimeters and kilograms.**

Size	NPS DN	1/2 15	3/4 20	1 25	1-1/2 40	2 50
A-End-to-End		3.38 86	3.38 86	4.00 102	4.75 121	5.25 133
B-Open		6.50 165	6.50 165	8.31 236	10.12 257	11.10 282
C-Closed		5.88 149	5.88 149	7.38 187	8.69 221	9.41 239
D-Seat Diameter		.50 12.7	.50 12.7	.75 19.1	1.25 31.8	1.50 38.1
E-Handwheel Diameter		4.00 102	4.00 102	4.75 121	5.75 146	7.00 178
Weight		3.5 1.6	3.4 1.5	6.2 2.8	10.9 4.9	16.0 7.3

+ Valves contain TEFLON—maximum temperature 500°F.  
Refer to pages 116-120 for full materials description.

For Cv factors see page 123, Valve Matrix A.

## Forged Gate Valves

### Class 800 (PN 130)

#### Conventional Port

1975 PSI @ 100°F (136.2 BAR @ 38°C)

For other ratings see pgs. 112-115

#### A105 Body/Bonnet

##### SERIES NUMBER

 Threaded  
2811

 Socket Weld  
SW 2811  
Trim: 13% Cr.  
Seats: HF

 THD/SW  
TSW2811

2811FHF

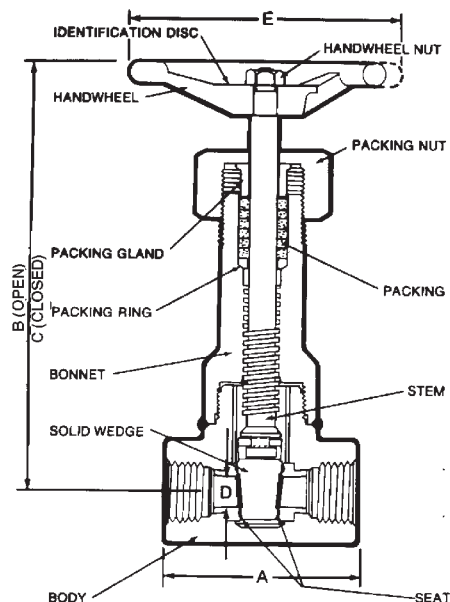
 SW2811FHF  
Trim: 13% Cr.  
Wedge/Seats: HF

- Welded Bonnet
- Inside Screw Stem
- Screw Gland
- Solid Wedge
- Hard Faced Seats
- API 602
- ASME B16.34

### Dimensions

**Bold face numerals are in inches and pounds.**  
*Blue numerals are in millimeters and kilograms.*

Size	NPS DN	1/2 15	3/4 20	1 25	1-1/4 32	1-1/2 40	2 50
A-End-to-End		3.38	3.38	4.00	4.75	4.75	5.25
		70	86	102	121	121	133
B-Open		6.62	6.62	8.38	10.81	10.81	12.12
		168	168	213	275	275	308
C-Closed		6.00	6.00	7.44	9.38	9.38	10.56
		152	152	189	238	238	268
D-Seat Diameter		.50	.50	.75	1.25	1.25	1.50
		12.7	12.7	191	31.8	31.8	38.1
E-Handwheel Diameter		4.00	4.00	4.75	5.75	5.75	7.00
		102	102	121	146	146	178
Weight		3.2	3.1	6.1	11.6	11.0	18.5
		1.5	1.4	2.8	5.3	5.0	8.4

Refer to pages 116-120 for full materials description.

For Cv factors see page 123, Valve Matrix A.

# Forged Gate Valves

## Class 800 (PN 130)

### Conventional Port

1975 PSI @ 100°F (136.2 BAR @ 38°C)

For other ratings see pgs. 112-115

#### SERIES NUMBER

**Body/Bonnet** Threaded  
**A105** 59851  
 Trim: 13% Cr.  
 Seats: HF

Socket Weld  
**SW59851**

**59851F8M** SW59851F8M  
 Trim: 316  
 Seats: HF

**59851MM** SW59851MM  
 Trim: Monel

**59851MBS** SW59851MBS  
 Trim: Monel  
 Wedge: HF

1920 PSI @ 100°F  
 (132.4 BAR @ 38°C)

**F316/** 59951  
**F316L** (Sizes 1/4-1 Only)  
**59951T+**  
 (Sizes 1/4-1 Only)  
 Trim: 316  
 Seats: HF

MATERIALS MEET  
 REQUIREMENTS OF  
 NACE STANDARD  
 MR-01-75 FOR  
 SOUR SERVICE

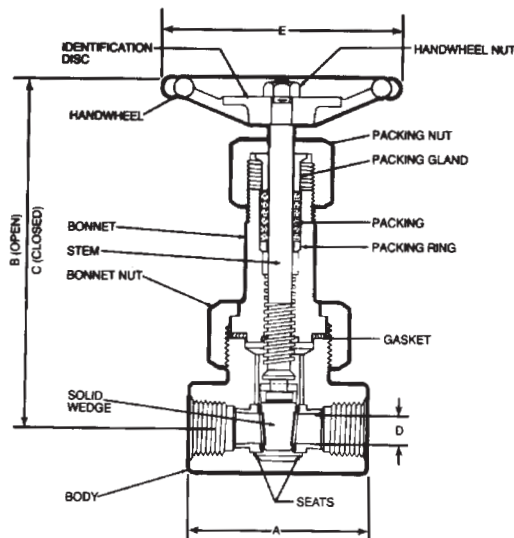

- Union Bonnet
- Spiral Wound Gasket
- Inside Screw Stem
- Screw Gland
- Solid Wedge
- Hard Faced Seats
- API 602
- ASME B16.34

## Dimensions

**Bold face numerals are in inches and pounds.**  
**Blue numerals are in millimeters and kilograms.**

Size	NPS DN	1/4 8	3/8 10	1/2 15	3/4 20	1 25	1-1/4 32	1-1/2 40	2 50
A-End-to-End		2.75 70	2.75 70	3.38 70	3.38 86	4.00 102	4.75 121	4.75 121	5.25 133
B-Open		6.44 164	6.44 164	6.44 164	6.44 164	8.38 213	10.69 272	10.69 272	12.25 311
C-Closed		5.88 149	5.88 149	5.88 149	5.88 149	7.44 189	9.25 235	9.25 235	10.56 239
D-Seat Diameter		.31 7.9	.31 7.9	.50 12.7	.50 12.7	.75 19.1	1.25 31.8	1.25 31.8	1.50 38.1
E-Handwheel Diameter		4.00 102	4.00 102	4.00 102	4.00 102	4.75 121	5.75 146	5.75 146	7.00 178
Weight		3.7 1.7	3.7 1.7	3.9 1.8	3.7 1.7	6.9 3.1	14.2 6.4	13.6 6.2	22.3 10.1

+ Valves contain TEFLON—maximum temperature 500°F.  
 Refer to pages 116-120 for full materials description.

For Cv factors see page 123, Valve Matrix A.

## Forged Gate Valves

### Class 800 (PN 130)

Full Port (Except 2-1/2 & 3)

1975 PSI @ 100°F (136.2 BAR @ 38°C)

For other ratings see pgs. 112-115

#### A105 Body/Bonnet

##### SERIES NUMBER

Threaded	Socket Weld
11103	SW11103
	Trim: 13% Cr.
	Seats: HF

Meets API-600 required wall thicknesses.

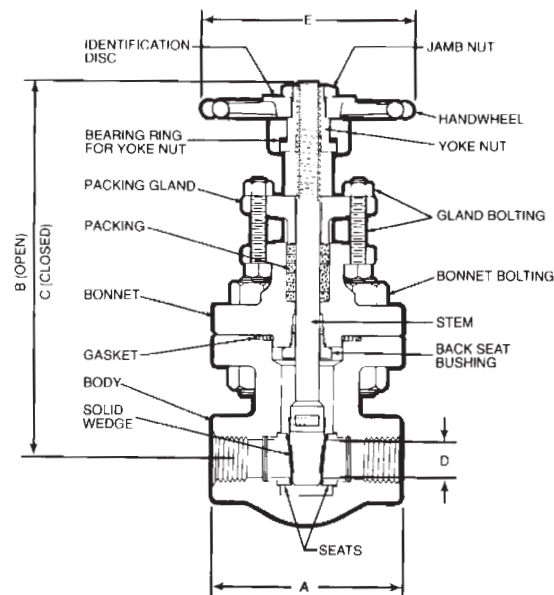

- Round Bolted Bonnet
- Spiral Wound Gasket
- Outside Screw & Yoke
- Bolted Gland
- Solid Wedge
- Hard Faced Seats
- ASME B16.34

### Dimensions

**Bold face numerals are in inches and pounds.**  
**Blue numerals are in millimeters and kilograms.**

Size	NPS DN	1/2 15	3/4 20	1 25	1-1/4 32	1-1/2 40	2 50	2-1/2 65	3 80
A-End-to-End		3.62	4.50	5.00	6.50	7.25	9.00	10.25	7.75
		92	114	127	165	184	229	260	197
B-Open		9.56	10.56	11.75	14.12	16.38	19.00	21.75	24.00
		243	268	298	359	416	483	552	610
C-Closed		8.78	9.62	10.56	12.62	14.69	16.81	19.00	20.75
		223	244	268	321	373	427	483	527
D-Seat Diameter		.56	.75	1.00	1.25	1.50	2.00	2.31	2.81
		14.2	19.1	25.4	31.8	38.1	50.8	58.7	71.4
E-Handwheel Diameter		4.75	5.75	7.00	8.00	9.75	9.75	12.00	13.75
		121	146	178	203	248	248	305	349
Weight		12.6	19.5	29.4	41.2	58.1	90.8	134	134
		5.7	8.9	13.3	18.7	26.4	41.2	60.8	60.8

Refer to pages 116-120 for full materials description.

For Cv factors see page 123, Valve Matrix C.

## Forged Gate Valves

### Class 1500 (PN 260)

API 602/ASME B16.34

Conventional Port

3705 PSI @ 100°F (255.5 BAR @ 38°C)

For other ratings see pgs. 112-115

#### A105 Body/Bonnet

**15373**      *SERIES NUMBER*  
Trim: 13% Cr.  
Seats: HF

**15373FHF**      Trim: 13% Cr.  
Wedge/Seats: HF

#### RING JOINT FACES

**RJ15373**      Trim: 13% Cr.  
Seats: HF

**RJ15373FHF**      Trim: 13% Cr.  
Wedge/Seats: HF

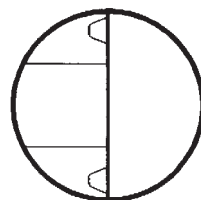

Ring Joint

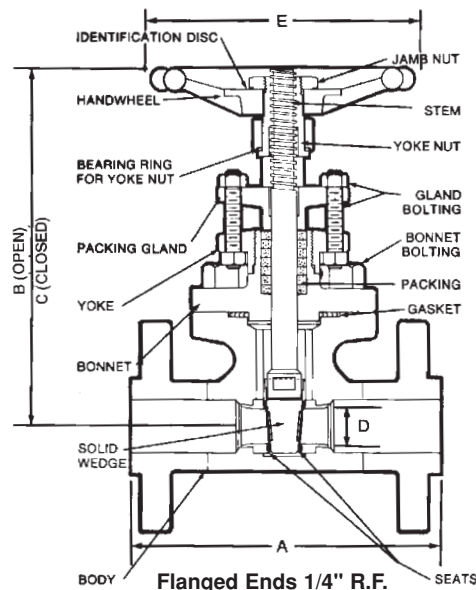

- Round Bolted Bonnet
- Spiral Wound Gasket
- Outside Screw & Yoke
- Bolted Gland
- Solid Wedge
- Hard Faced Seats
- Integral Hard Faced Seat
- ASME B16.34

**Bold face numerals are in inches and pounds.**  
**Blue numerals are in millimeters and kilograms.**

## Dimensions

Size	NPS DN	Class 1500 (Conventional Port):				
		1/2 15	3/4 20	1 25	1-1/2 40	2 50
A-End-to-End		8.50	9.00	10.00	12.00	14.50
		216	229	254	305	368
B-Open		7.47	7.47	9.69	11.38	13.84
		243	243	246	289	351
C-Closed		6.88	6.88	8.78	9.97	12.16
		175	175	268	253	309
D-Seat Diameter		.50	.50	.75	1.25	1.50
		12.7	12.7	19.1	31.8	38.1
E-Handwheel Diameter		4.75	4.75	7.00	8.00	9.75
		121	121	178	203	248
Weight		17.2	20.1	34.6	48.5	94.1
		7.8	9.1	15.7	22.0	42.7

Valve flanges conform to ASME Standard B16.5 and end-to-end dimensions conform to ASME Standard B16.10.

For Cv factors see page 123, Valve Matrix A.  
Refer to pages 116-120 for full materials description.

## Forged Gate Valves

### Class 1500 (PN 260)

ASME B16.34

Full Port

3705 PSI @ 100°F (255.5 BAR @ 38°C)

For other ratings see pgs. 112-115

A105 Body/Bonnet

SERIES NUMBER

11603 1/4" Raised Faces  
 11683 Ring Joint Faces  
 Trim: 13% Cr.  
 Seats: HF

Meets API-600 required wall thicknesses.

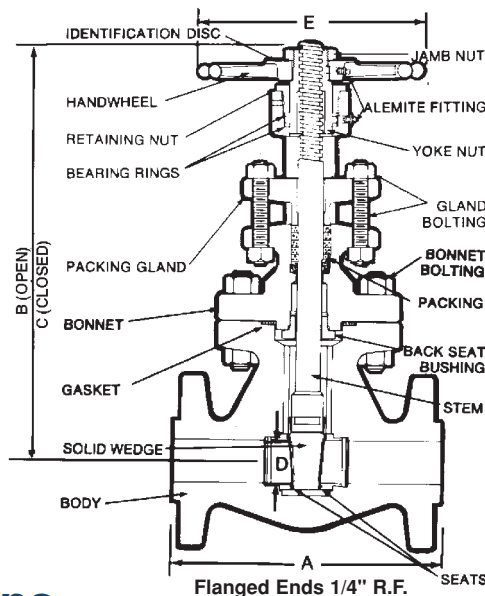

- Round Bolted Bonnet
- Spiral Wound Gasket
- Outside Screw & Yoke
- Bolted Gland
- Solid Wedge
- Hard Faced Seats
- Integral Hard Faced Seat
- ASME B16.34

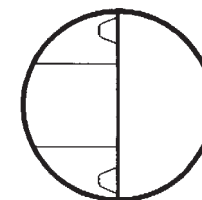

Ring Joint

**Bold face numerals are in inches and pounds.**  
**Blue numerals are in millimeters and kilograms.**

## Dimensions

### Class 1500 (Full Port):

Size	NPS DN	1/2 15	3/4 20	1 25	1-1/4 32	1-1/2 40	2 50
A-End-to-End		8.50 216	9.00 229	10.00 254	11.00 279	12.00 305	14.50 368
B-Open		12.12 308	14.00 356	15.62 397	17.75 451	20.12 511	23.56 598
C-Closed		11.38 289	12.94 329	14.50 368	16.44 418	18.38 467	21.25 540
D-Seat Diameter		.56 14.2	.75 19.1	.88 22.4	1.12 28.4	1.38 35.0	2.00 50.8
E-Handwheel Diameter		7.00 178	7.00 178	8.00 203	9.75 248	12.00 305	13.75 349
Weight		43.3 19.7	55.0 25.0	76.0 34.5	92.0 41.8	117.8 53.5	230 104.4

Valve flanges conform to ASME Standard B16.5 and end-to-end dimensions conform to ASME Standard B16.10.

For Cv factors see page 123, Valve Matrix G.  
 Refer to pages 116-120 for full materials description.

## Forged Gate Valves

### Class 1500 (PN 260)

#### Full Port

3705 PSI @ 100°F (255.5 BAR @ 38°C)

For other ratings see pgs. 112-115

#### A105 Body/Bonnet

##### SERIES NUMBER

Threaded	Socket Weld
<b>1033</b>	<b>SW1033</b>
<b>1043</b>	<b>SW1043</b> Ring Joint Gasket Bonnet (Not illustrated)
	Trim: 13% Cr.
	Seats: HF

Meets API-600 required wall thicknesses.

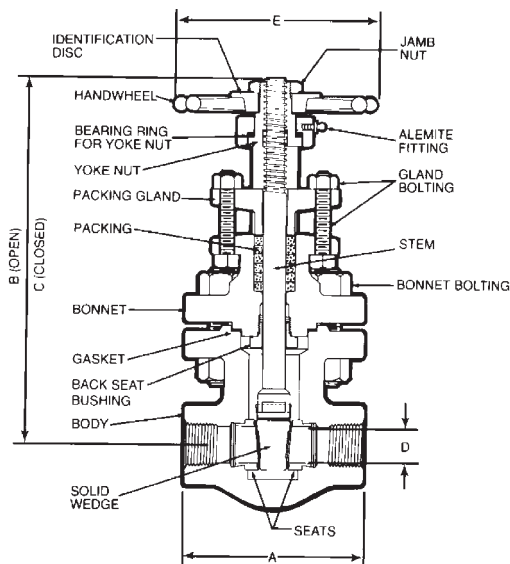

- Round Bolted Bonnet
- Flat Gasket Joint or Ring Joint Gasket
- Outside Screw & Yoke
- Bolted Gland
- Solid Wedge
- Hard Faced Seats
- ASME B16.34

### Dimensions

**Bold face numerals are in inches and pounds.**  
**Blue numerals are in millimeters and kilograms.**

Size	NPS DN	1/2 15	3/4 20	1 25	1-1/4 32	1-1/2 40	2 50
A-End-to-End		4.50	5.00	6.50	7.25	9.00	9.50
		114	127	165	184	229	241
B-Open		10.75	11.69	14.06	16.38	18.75	21.00
		273	297	357	416	476	533
C-Closed		10.00	10.75	12.94	14.88	17.12	18.69
		254	273	329	378	435	475
D-Seat Diameter		.56	.75	.88	1.25	1.38	2.00
		14.2	191	22.3	31.8	35.1	50.8
E-Handwheel Diameter		5.75	7.00	8.00	9.75	9.75	12.00
		146	178	203	248	248	305
Weight		21.9	29.9	44.4	63.0	100	116.3
		9.9	13.6	20.2	28.6	45.4	52.8

Refer to pages 116-120 for full materials description.

For Cv factors see page 123, Valve Matrix G.

## Forged Gate Valves

### Class 1500 (PN 260)

#### Conventional Port

3705 PSI @ 100°F (255.5 BAR @ 38°C)

For other ratings see pgs. 112-115

#### SERIES NUMBER

Body/Bonnet	Threaded	Socket Weld
A105	15111	SW15111 Trim: 13% Cr. Seats: HF
	15111F8M	SW15111F8M Trim: 316 Seats: HF
	15111FHF	SW15111FHF Trim: 13% Cr. Wedge/Seats: HF
	15111MB6	SW15111MB6 Trim: 13% Cr. Wedge/Seats: HF
	15111MBS	SW15111MBS Trim: Monel Wedge/Seats: HF
	15111MB8	SW15111MB8 Trim: 316 Wedge/Seats: HF
<hr/>		
F11 CL2	3750 PSI @ 100°F (258.6 BAR @ 38°C) 15321	SW15321 Trim: 13% Cr. Seats: HF
<hr/>		
F316/ F316L	3600 PSI @ 100°F (248.3 BAR @ 38°C) 15401	SW15401 Sizes 1/2-2 (No 1-1/4) Trim: 316 Seats: HF

MATERIALS MEET  
REQUIREMENTS OF  
NACE STANDARD  
MR-01-75 FOR  
SOUR SERVICE

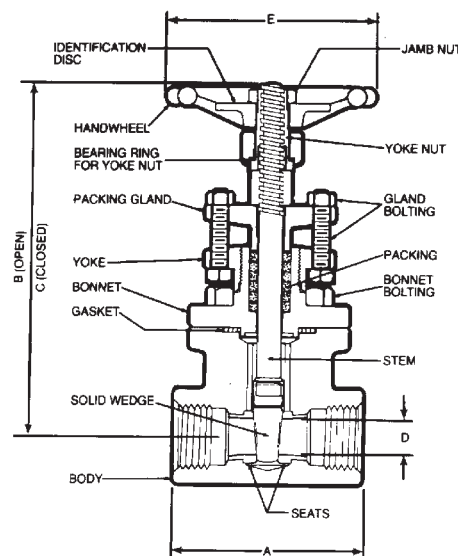

- Round Bolted Bonnet
- Spiral Wound Gasket
- Outside Screw & Yoke
- Bolted Gland
- Solid Wedge
- Hard Faced Seats
- API 602
- ASME B16.34

### Dimensions

**Bold face numerals are in inches and pounds.**  
**Blue numerals are in millimeters and kilograms.**

Size	NPS DN	1/2 15	3/4 20	1 25	1-1/4 32	1-1/2 40	2 50
A-End-to-End		4.00 102	4.00 102	4.75 121	5.25 133	5.25 133	7.00 178
B-Open		7.47 190	7.47 190	9.69 246	11.38 289	11.38 289	13.84 351
C-Closed		6.88 175	6.88 175	8.78 223	9.97 253	9.97 253	12.16 309
D-Seat Diameter		.50 12.7	.50 12.7	.75 19.1	1.25 31.8	1.25 31.8	1.50 38.1
E-Handwheel Diameter		4.75 121	4.75 121	7.00 178	8.00 203	8.00 203	9.75 248
Weight		8.5 3.9	8.4 3.8	18.0 8.2	27.0 12.3	26.9 12.2	48.2 21.9

Refer to pages 116-120 for full materials description.

For Cv factors see page 123, Valve Matrix A.

## Forged Gate Valves – ASTM A350, Grade LF2 for Temperatures to –50°F (–46°C)

### Class 1500 (PN 260) Conventional Port

3705 PSI @ 100°F (255.5 BAR @ 38°C)  
3705 PSI @ -50°F (255.5 BAR @ -46°C)

For other ratings see pgs. 112-115

#### A350, Gr. LF2 Body/Bonnet

##### SERIES NUMBER

Threaded	Socket Weld
<b>35111</b>	<b>SW35111</b> Trim: 13% Cr. Seats: HF
<b>35111F8M</b>	<b>SW35111F8M</b> Trim: 316 Seats: HF
<b>35111MB8</b>	<b>SW35111MB8</b> Trim: 316 Wedge/Seats: HF

GATE CLASS 1500 (PN 260) 35111

MATERIALS MEET REQUIREMENTS OF NACE STANDARD MR-01-75 FOR SOUR SERVICE

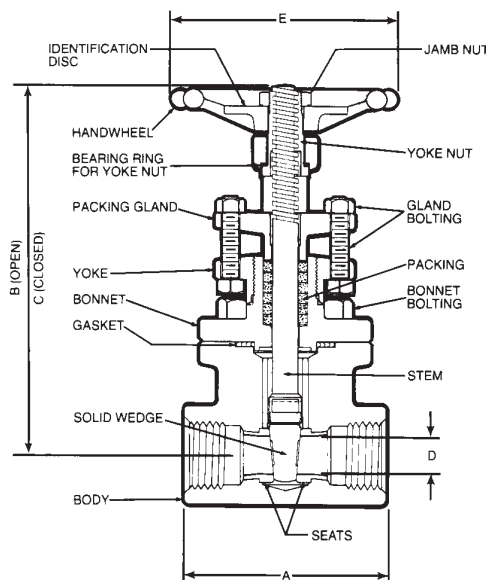

- Round Bolted Bonnet
- Spiral Wound Gasket
- Outside Screw & Yoke
- Bolted Gland
- Solid Wedge
- Hard Faced Seats
- API 602
- ASME B16.34

### Dimensions

**Bold face numerals are in inches and pounds.**  
**Blue numerals are in millimeters and kilograms.**

Size	NPS DN	1/2 15	3/4 20	1 25	1-1/2 40	2 50
A-End-to-End		4.00 102	4.00 102	4.75 121	5.25 133	7.00 178
B-Open		7.47 190	7.47 190	9.69 246	11.38 289	13.84 351
C-Closed		6.88 175	6.88 175	8.78 223	9.97 253	12.16 309
D-Seat Diameter		.50 12.7	.50 12.7	.75 19.1	1.25 31.8	1.50 38.1
E-Handwheel Diameter		4.75 121	4.75 121	7.00 178	8.00 203	9.75 248
Weight		8.5 3.9	8.4 3.8	18.0 8.2	26.9 12.2	48.2 21.9

Refer to pages 116-120 for full materials description.

For Cv factors see page 123, Valve Matrix A.

## Forged Gate Valves

### Class 1500 (PN 260)

Full Port

3705 PSI @ 100°F (255.5 BAR @ 38°C)

For other ratings see pgs. 112-115

#### A105 Body/Bonnet

##### SERIES NUMBER

Threaded  
16111

Socket Weld  
SW16111  
Trim: 13% Cr.  
Seats: HF

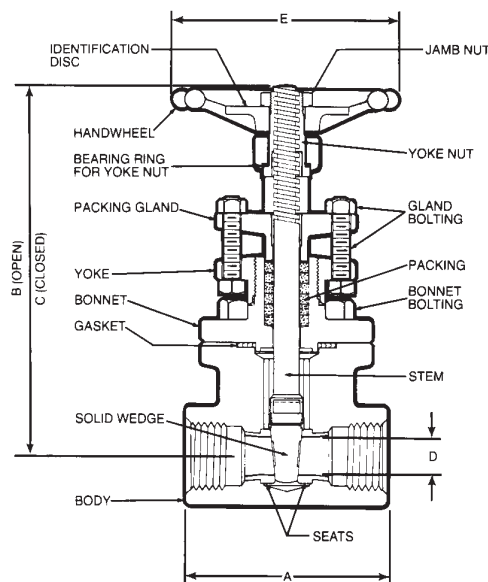

- Round Bolted Bonnet
- Spiral Wound Gasket
- Outside Screw & Yoke
- Bolted Gland
- Solid Wedge
- Hard Faced Seats
- API 602
- ASME B16.34

### Dimensions

**Bold face numerals are in inches and pounds.**  
*Blue numerals are in millimeters and kilograms.*

Size	NPS DN	1/2 15	3/4 20	1 25	1-1/4 32	1-1/2 40
A-End-to-End		4.00 102	4.75 121	5.25 133	5.25 133	7.00 178
B-Open		7.47 190	9.69 246	11.12 282	11.38 289	13.84 351
C-Closed		6.88 175	8.78 223	9.97 253	9.97 253	12.16 309
D-Seat Diameter		.50 12.7	.75 19.1	1.00 25.4	1.25 31.8	1.50 38.1
E-Handwheel Diameter		4.75 121	7.00 178	8.00 203	8.00 203	9.75 248
Weight		8.5 3.9	17.5 7.9	28.5 12.9	27.0 12.3	48.2 21.9

Refer to pages 116-120 for full materials description.

For Cv factors see page 123, Valve Matrix B.

# Forged Gate Valves

## Class 1500 (PN 260)

### Conventional Port

3705 PSI @ 100°F (255.5 BAR @ 38°C)

For other ratings see pgs. 112-115

#### A105 Body/Bonnet

	SERIES NUMBER
Threaded 15801	Socket Weld SW15801 Trim: 13% Cr. Seats: HF
15801FHF	SW15801FHF Trim: 13% Cr. Wedge/Seats: HF
15801MM	SW15801MM Trim: Monel
15801MB8	SW15801MB8 Trim: 316 Wedge/Seats: HF
15801MBS	SW15801MBS Trim: Monel Wedge: HF

MATERIALS MEET REQUIREMENTS OF NACE STANDARD MR-01-75 FOR SOUR SERVICE

#### F316/F316L

3600 PSI @ 100°F (248.3 BAR @ 38°C)
15831
SW15831
Trim: 316
Seats: HF

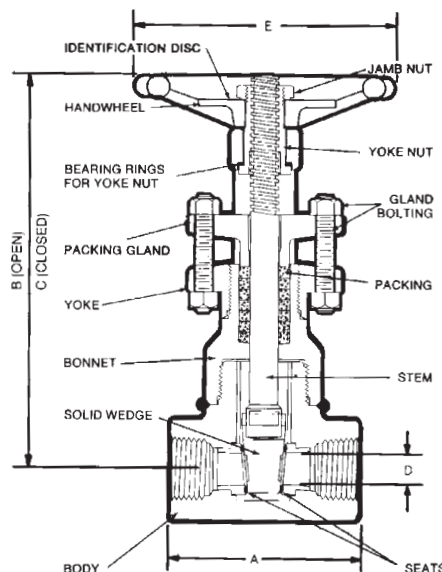

- Welded Bonnet
- Outside Screw & Yoke
- Bolted Gland
- Solid Wedge
- Hard Faced Seats
- API 602
- ASME B16.34

## Dimensions

**Bold face numerals are in inches and pounds.**  
**Blue numerals are in millimeters and kilograms.**

Size	NPS DN	1/2 15	3/4 20	1 25	1-1/4 32	1-1/2 40	2 50
A-End-to-End		4.00	4.00	4.75	5.25	5.25	7.00
		102	102	121	133	133	178
B-Open		7.53	7.53	9.69	11.41	11.41	13.84
		191	191	246	290	290	352
C-Closed		6.88	6.88	8.78	9.97	9.97	12.16
		175	175	223	253	253	309
D-Seat Diameter		.50	.50	.75	1.25	1.25	1.50
		12.7	12.7	19.1	31.8	31.8	38.1
E-Handwheel Diameter		4.75	4.75	7.00	8.00	8.00	9.75
		121	121	178	203	203	248
Weight		7.4	7.2	13.5	18.2	17.5	37.0
		3.4	3.3	6.1	8.3	7.9	16.8

Refer to pages 116-120 for full materials description.

For Cv factors see page 123, Valve Matrix A.

## Forged Gate Valves – Extended Body Valves

### Class 1500 (PN 260)

#### Conventional Port

For other ratings see pgs. 112-115

#### A105 Body/Bonnet

3705 PSI @ 100°F (255.5 BAR @ 38°C)

#### SERIES NUMBER

ST 15801 Trim: 13% Cr.  
Seats: HF

ST 15801F8M Trim: 316  
Seats: HF

#### TYPE ENDS

Integral Male  
Socket Weld  
Female Threaded

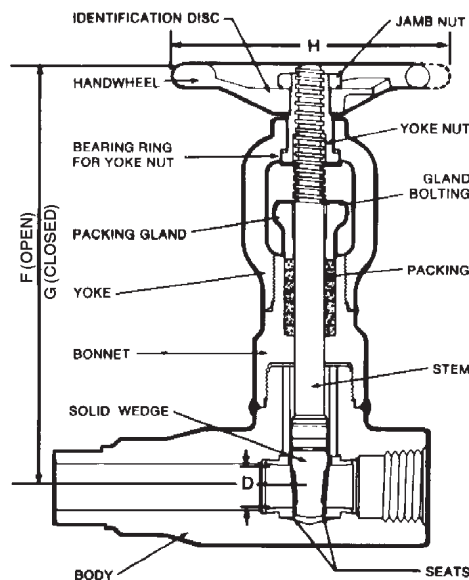
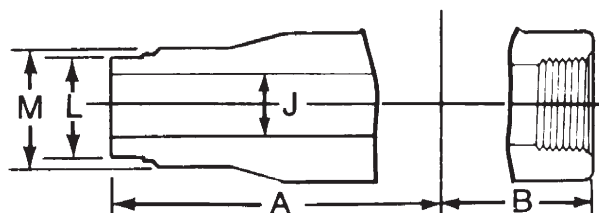

- Welded Bonnet
- Outside Screw & Yoke
- Bolted Gland
- Solid Wedge
- Hard Faced Seats
- API 602
- ASME B16.34

### Dimensions

Size	NPS DN	1/2 15	3/4 20	1 25
A		4.69 119	4.69 119	5.38 137
B		2.00 51	2.00 51	2.38 60
D		.50 12.7	.50 12.7	.75 19.1
F		7.53 191	7.53 191	9.69 246
G		6.88 175	6.88 175	8.78 223
H		4.75 121	4.75 121	7.00 178
J		.69 17.5	.69 17.5	1.12 28.4
L		.84 21.3	1.05 26.7	1.32 33.5
M		1.56 39.6	1.56 39.6	2.25 57.2
Weight		8.7 4.0	8.5 3.9	14.0 6.4

Refer to Pages 116-120 for full materials description.  
For Cv factors see Page 123 Valve Matrix A.

## Forged Gate Valves

### Class 2500 (PN 420)

#### Full Port

6250 PSI @ 100°F (431.0 BAR @ 38°C)

For other ratings see pgs. 112-115

#### SERIES NUMBER

Body/Bonnet	Threaded	Socket Weld
<b>A105</b>	<b>66703</b>	<b>SW66703</b> Trim: 13% Cr. Wedge/Seats: HF
<b>F11, Cl. 2</b> (1-1/4% Cr.)	<b>66713</b>	<b>SW66713</b> Trim: 13% Cr. Wedge/Seats: HF
<b>F22, Cl. 3</b> (2-1/4% Cr.)	<b>66773</b>	<b>SW66773</b> Trim: 13% Cr. Wedge/Seats: HF

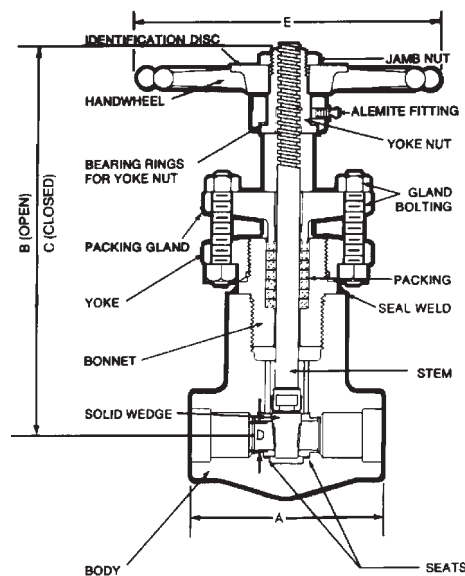

- Welded Bonnet
- Outside Screw & Yoke
- Bolted Gland
- Solid Hard Faced Wedge
- Hard Faced Seats
- ASME B16.34 LTD. Pressure Class

### Dimensions

*Bold face numerals are in inches and pounds.  
Blue numerals are in millimeters and kilograms.*

Size	NPS DN	1/2 15	3/4 20	1 25	1-1/2 40	2 50
A-End-to-End		4.00 102	5.12 130	5.12 130	8.50 216	8.50 216
B-Open		8.81 224	11.00 279	11.00 279	15.88 403	15.88 403
C-Closed		8.19 208	10.00 254	10.00 254	14.06 357	14.06 357
D-Seat Diameter		.41 10.4	.75 19.1	.75 19.1	1.50 38.1	1.50 38.1
E-Handwheel Diameter		5.75 146	8.00 203	8.00 203	12.00 305	12.00 305
Weight		8.7 3.9	21.0 9.5	20.1 9.1	65.7 29.8	65.5 29.7

Refer to pages 116-120 for full materials description.

For Cv factors see page 123, Valve Matrix H.

# Forged Gate Valves – ASTM A350, GRADE LF2 Class 800 and Class 1500 Valves

FOR APPLICATIONS WHERE TEMPERATURES TO  $-50^{\circ}\text{F}$  ( $-46^{\circ}\text{C}$ ) ARE THE RULE NOT THE EXCEPTION!

PRESSURE-TEMPERATURE RATINGS		
Service Temperature ( $^{\circ}\text{F}$ )	CLASS 800 ASTM A350, GR. LF2 (1) (2) PSI	CLASS 1500 ASTM A350, GR. LF2 (1) (2) PSI
-50 to 100	1975	3705
200	1800	3375
300	1750	3280
400	1690	3170
500	1595	2995
600	1460	2735
700	1420	2665
800	1100	2060

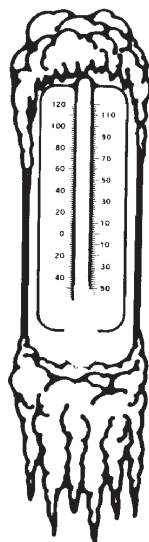

PRESSURE-TEMPERATURE RATINGS		
Service Temperature ( $^{\circ}\text{C}$ )	PN 130 (CLASS 800) ASTM A350, GR. LF2 (1) (2) BAR	PN 260 (CLASS 1500) ASTM A350, GR. LF2 (1) (2) BAR
-46 to 38	136.2	255.5
50	133.5	250.5
100	123.7	232.0
150	120.6	226.0
200	116.9	219.2
250	111.2	208.8
300	103.3	193.6
400	92.1	172.5
425	76.9	144.0

- Traceable Parts From Stock
- Machined Parts Heat Treated to ASTM A350, Grade LF2
- Charpy Impact Tested
- Verified Strength and Toughness
- Flexible Graphite Packing
- Flexible Graphite Filled Gasket
- API 602
- ASME B16.34

(1) Ratings are in accordance with ASME/ANSI B16.34-96.  
 (2) Permissible but not recommended for prolonged use above  $800^{\circ}\text{F}$  ( $427^{\circ}\text{C}$ ).

GATE  
 CLASS 800 (PN 130), CLASS 1500 (PN 260)  
 32111, 35111

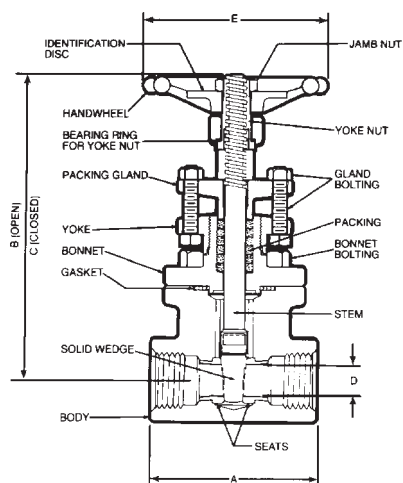

## Class 800 (PN 130)\* Conventional Port

1975 PSI @  $100^{\circ}\text{F}$  (136.2 BAR @  $38^{\circ}\text{C}$ )

A350, GR. LF2 Body/Bonnet

*SERIES NUMBER*  
 Threaded Socket Weld  
 Size 1/2"-2"  
**32111** SW32111  
 Trim: 13% Cr.  
 Seats: HF

**32111F8M** SW32111F8M  
 Trim: 316  
 Seats: HF

**32111MB8** SW32111MB8  
 Trim: 316  
 Wedge/Seats: HF

See Dimensions on Pg. 18

Refer to pages 116-120 for full materials description.

## Class 1500 (PN 260)\* Conventional Port

3705 PSI @  $100^{\circ}\text{F}$  (255.5 BAR @  $38^{\circ}\text{C}$ )

A350, GR. LF2 Body/Bonnet

*SERIES NUMBER*  
 Threaded Socket Weld  
 Size 1/2"-2"  
**35111** SW35111  
 Trim: 13% Cr.  
 Seats: HF

**35111F8M** SW35111F8M  
 Trim: 316  
 Seats: HF

**35111MB8** SW35111MB8  
 Trim: 316  
 Wedge/Seats: HF

See Dimensions on Pg. 38

For Cv factors see page 123, Valve Matrix A.

MATERIALS  
 MEET  
 REQUIREMENTS  
 OF NACE  
 STANDARD  
 MR-01-75 FOR  
 SOUR SERVICE

\*NOTE: Other Vogt valves are also offered in A350-LF2 construction. See individual pages of VV200 Catalog.

# Forged Nuclear Valves – Nuclear Gate, Globe and Check

## Vogt Valves for Nuclear Service



Class 1, 2, 3

Vogt offers Class 1, 2 or 3 gate, globe and check valves of forged carbon and stainless steel in 1/4" to 2" sizes, in ASME Section III "N" stamp construction. Pressure classes 150, 300, 600, 900 and 1500 are offered. Unlike many others, Vogt designs, manufactures and tests all pressure boundary parts at one location to insure complete satisfaction of customer and N-stamp code requirements.

The chart shows dimensions of popular Vogt nuclear valves. Other Vogt valve designs can also be constructed to Section III requirements.

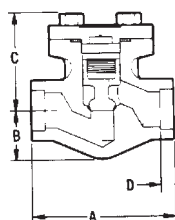
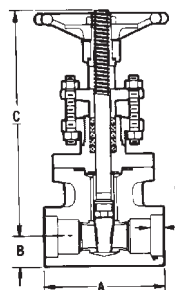
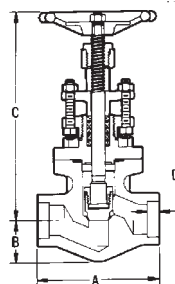

*Bold face numerals are in inches. Blue numerals are in millimeters.*

SIZE & TYPE	NPS DN	1/4 8	3/8 10	1/2 15	3/4 20	1 25	1-1/4 32	1-1/2 40	2 50
150 300 600 GLOBE VALVE	A	3.75 95	3.75 95	3.75 95	4.00 102	4.62 117	6.25 159	6.25 159	7.75 197
	B	1.00 25	1.00 25	1.00 25	1.12 28	1.56 40	2.25 57	2.25 57	2.69 68
	C	6.62 168	6.62 168	6.62 168	6.62 168	8.44 214	10.38 264	10.38 264	10.88 276
	MIN. D	.38 9.7	.38 9.7	.38 9.7	.50 12.7	.50 12.7	.50 12.7	.50 12.7	.62 15.7
900 1500 GLOBE VALVE	A	4.50 114	4.50 114	4.50 114	4.50 114	6.25 159	7.75 197	7.75 197	9.00 229
	B	1.56 40	1.56 40	1.56 40	1.56 40	2.25 57	2.69 68	2.69 68	3.50 89
	C	7.91 201	7.91 201	7.91 201	7.91 201	10.00 254	10.97 279	10.97 279	13.31 338
	MIN. D	.38 9.7	.38 9.7	.38 9.7	.50 12.7	.50 12.7	.50 12.7	.50 12.7	.62 15.7
150 300 600 GATE VALVE	A	3.30 84	3.30 84	3.30 84	3.50 89	4.56 116	4.75 121	4.75 121	5.25 133
	B	1.00 25	1.00 25	1.00 25	1.12 28	1.56 40	1.28 33	1.28 33	1.56 40
	C	6.50 165	6.50 165	6.50 165	6.50 165	8.31 211	10.12 257	10.12 257	11.10 282
	MIN. D	.38 9.7	.38 9.7	.38 9.7	.50 12.7	.50 12.7	.50 12.7	.50 12.7	.62 15.7
900 1500 GATE VALVE	A	4.00 102	4.00 102	4.00 102	4.00 102	4.75 121	5.25 133	5.25 133	7.00 178
	B	.97 25	.97 25	.97 25	.97 25	1.28 33	1.56 40	1.56 40	1.88 48
	C	7.47 190	7.47 190	7.47 190	7.47 190	9.69 246	11.38 289	11.38 289	13.84 352
	MIN. D	.38 9.7	.38 9.7	.38 9.7	.50 12.7	.50 12.7	.50 12.7	.50 12.7	.62 15.7
150 300 600 CHECK VALVE	A	3.75 95	3.75 95	3.75 95	4.00 101	4.62 117	6.25 159	6.25 159	7.75 197
	B	1.00 25	1.00 25	1.00 25	1.12 28	1.56 40	2.25 57	2.25 57	2.69 68
	C	2.56 65	2.56 65	2.56 65	2.56 65	3.06 78	4.50 114	4.50 114	4.94 125
	MIN. D	.38 9.7	.38 9.7	.38 9.7	.50 12.7	.50 12.7	.50 12.7	.50 12.7	.62 15.7
900 1500 CHECK VALVE	A	4.50 114	4.50 114	4.50 114	4.50 114	6.25 159	7.75 197	7.75 197	9.00 229
	B	1.56 40	1.56 40	1.56 40	1.56 40	2.25 57	2.69 68	2.69 68	3.50 89
	C	3.06 78	3.06 78	3.06 78	3.06 78	4.41 112	5.03 128	5.03 128	6.12 155
	MIN. D	.38 9.7	.38 9.7	.38 9.7	.50 12.7	.50 12.7	.50 12.7	.50 12.7	.62 15.7

The following trims are available: Stems - 316SS, 416SS, 17-4PH  
Disc/Gates - 410SS, 410SSHF, 316SS, 316SSHF

Gate Seats - 410SSHF, 316SSHF  
Globe Seats - Integral, Integral HF

Refer to pages 116-120 for full materials description.

## Forged Valves and Fittings – For Sour Service

### NACE (National Association of Corrosion Engineers) Standard MR-01-75:<sup>(1)</sup>

A number of outside screw and yoke (OS&Y) and inside screw (ISS) valves utilizing fabrication processes, welds and materials selected from NACE MR-01-75 are offered. These valves are carried in stock and are available with written certification to NACE Standard MR-01-75 "SULFIDE STRESS CRACKING (SSC) RESISTANT METALLIC MATERIAL FOR OIL FIELD EQUIPMENT" when specified. Vogt Valve Company takes extreme care to control the manufacturing process for valve trim parts, bolting, and pressure boundary welds to maintain appropriate chemistry and mechanical properties which are resistant to SSC.

In addition to H<sub>2</sub>S, carbon dioxide (CO<sub>2</sub>) and water containing chlorides may also be present in crude oils and gases. This environment can lead to degradation of exposed material by weight loss corrosion (pitting, crevice and general corrosion) and other forms of environmental embrittlement.

MR-01-75 covers only materials resistant to SSC but other considerations must be recognized and properly dealt with to assure efficient and safe control of hazardous media.

Vogt offers a number of popular trim packages for their NACE valves processed to the NACE MR-01-75 requirements and noted in the table below.

**Fittings:** All Vogt fittings noted in the VV200 Catalog meet NACE MR-01-75 requirements from stock.

### NACE MR-01 75 addresses bolting requirements in two categories:

- 1. Exposed Bolting:** Bolting which in service is exposed directly to the sour environment or which will be buried, insulated or equipped with flange protectors or otherwise denied direct exposure to the open atmosphere.
- 2. Non Exposed Bolting:** Bolting which is exposed to the open atmosphere rather than the sour environment.

Vogt NACE valves use bonnet bolting meeting the exposed bolting requirements of NACE MR-01-75. NACE bolting, other than Vogt standard, can be provided at the option of the end user.

### TRIM SUFFIX DESIGNATIONS:

(Used with series numbers to indicate special characteristics of sour service valves).

#### SUFFIX<sup>(2)</sup> SPECIAL CHARACTERISTICS

<b>MBS<sup>(3)</sup> (Monel) Gasket</b>	Monel Trim
	Monel/Flexible Graphite Spiral Wound
<b>MB8<sup>(4)</sup> (316SS)</b>	Flexible Graphite Packing
	B7M Bonnet Bolting Full Rating
<b>MB6 (13 Cr.)</b>	Solution Annealed 316 Trim
	316/Flexible Graphite Spiral Wound Gasket Flexible Graphite Packing B8MCL1 Bonnet Bolting Hard Faced Seats and Gate (or Disc) Full Rating
<b>MB6 (13 Cr.)</b>	Soft 13Cr. Trim
	304/Flexible Graphite Spiral Wound Gasket Flexible Graphite Packing B7M Bonnet Bolting Hard Faced Seats and Gate (or Disc) Full Rating

### TRIM SUGGESTIONS CHART:

(For oil/gas sour service environments in -20°F to 800°F temperature range).

ENVIRONMENT	SUGGESTED TRIM
H <sub>2</sub> S and H <sub>2</sub> O	316 or 13 Cr.
H <sub>2</sub> S, H <sub>2</sub> O, CO <sub>2</sub>	316, 13 Cr. or Monel
H <sub>2</sub> S, H <sub>2</sub> O and Chlorides	Monel or 13 Cr.
H <sub>2</sub> S, H <sub>2</sub> O, CO <sub>2</sub> and Chlorides	Monel or 13 Cr.

- MR-01-75 is a material standard—not a design standard. It is an aid in the selection of materials for those "Sour Environment" applications with conditions present which could result in SSC. The standard discusses the sour environment and presents guidelines in the H<sub>2</sub>S concentration and pressure relationships where SSC can occur in sour gas and sour multiphase systems. The standard has an excellent listing of ferrous and non-ferrous materials that are resistant to SSC. Copies of MR-01-75, including revisions, can be obtained by writing: NACE, P. O. Box 218340, Houston, Texas 77218.
- See the individual pages of the VV200 Catalog for Vogt valves available with the various NACE trim packages. If not listed, please make inquiry because most Vogt valve designs can be supplied with one of the trim packages listed.
- In multiphase systems significant general corrosion may occur for monel trim at service temperatures above 300°F when CO<sub>2</sub>, H<sub>2</sub>S and Chlorides are present.
- CHECK/GLOBE - Discs and integral seats are hard faced. The disc is solution annealed after machining to assure Rc-22 Max. hardness. GATE - Seats and wedge are hard faced and solution annealed after machining to assure Rc-22 Max. hardness.

Refer to pages 116-120 for full materials description.